



Super Duper® Series

BK-266

Vocabulary Building

with
Antonyms, Synonyms,
Homophones and Homographs

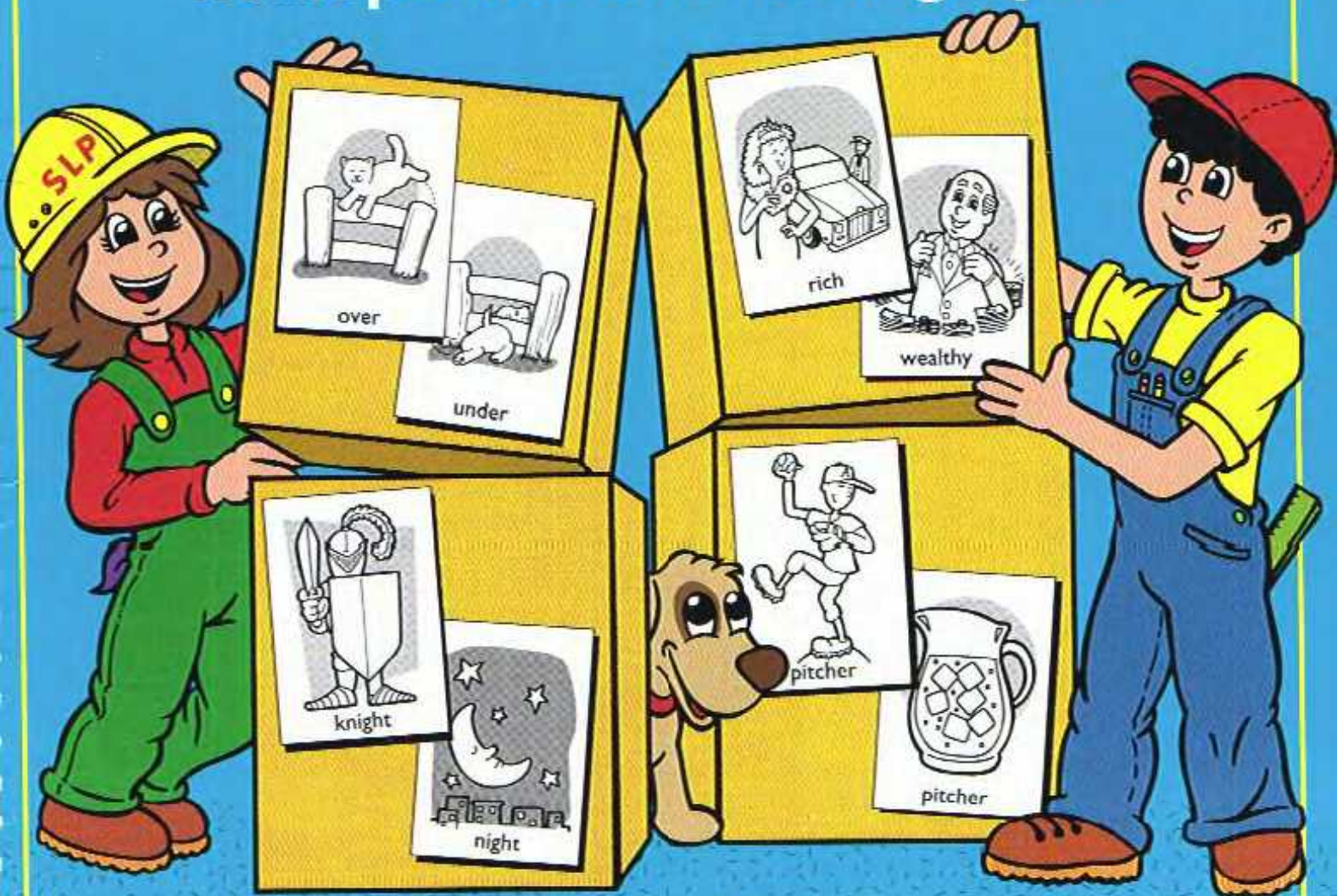

By Jo Ann Gordon

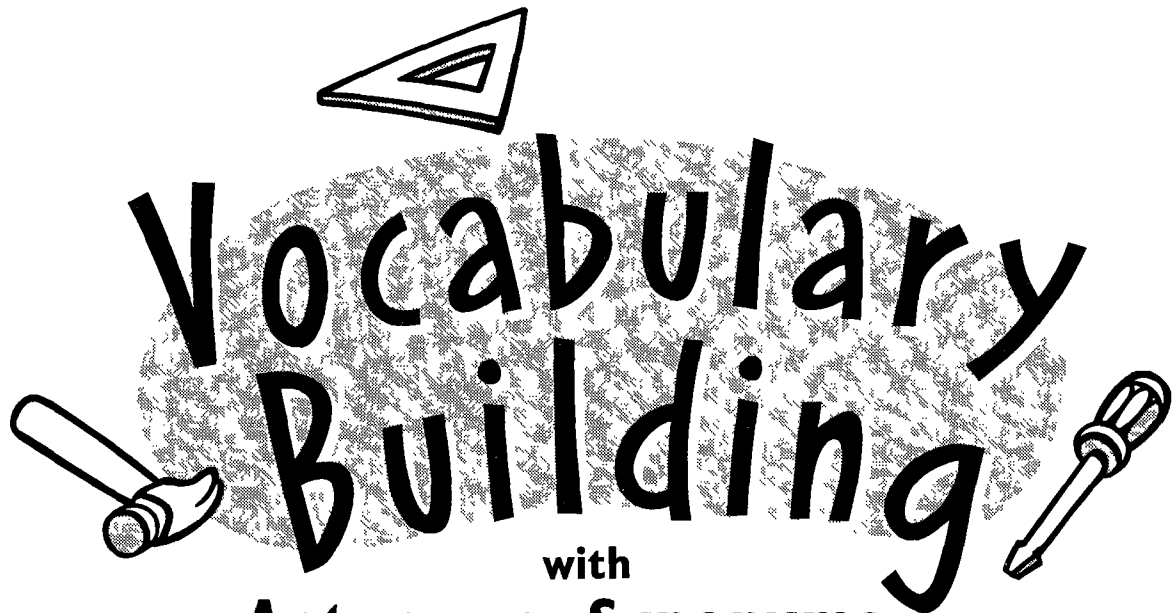

Vocabulary Building

with
**Antonyms, Synonyms,
Homophones and Homographs**

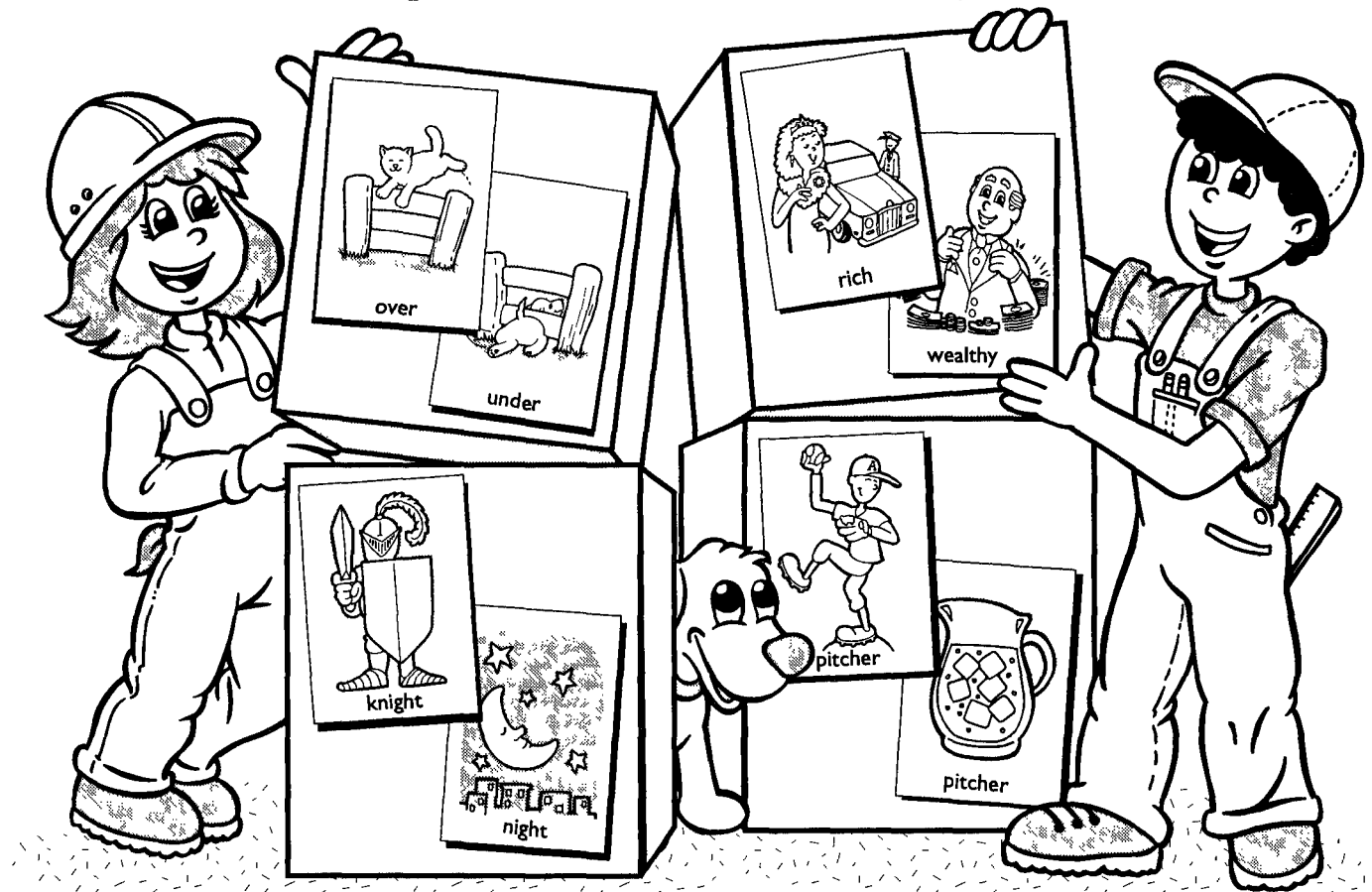

By Jo Ann Gordon

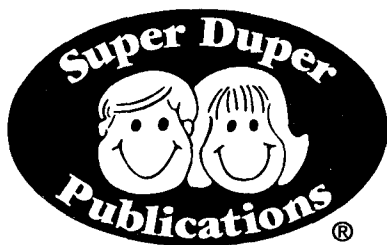

Copyright ©1998 by SUPER DUPER® PUBLICATIONS. A division of Super Duper,® Inc. All rights reserved. Permission is granted for the user to reproduce the material contained herein in limited form for classroom use only. Reproduction of this material for an entire school or school system is strictly prohibited.

Post Office Box 24997, Greenville, South Carolina 29616
1-800-277-8737 Fax 1-800-978-7379

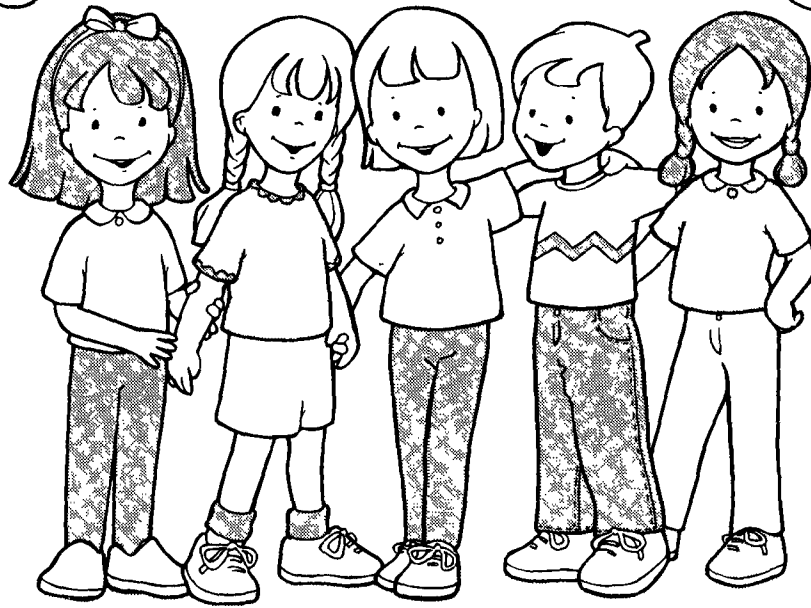

*Dedicated to all my
friends and to my
mother who always
believed in me.*

- Jo Ann Gordon



Introduction

Speech-Language impaired children usually meet with a great deal of frustration when trying to understand and utilize written and spoken vocabulary. There are so many confusing rules to remember and so many different concepts to grasp. Many children just give up trying and will guess at correct word usage. Speech-Language Pathologists (or Therapists) and regular classroom teachers are also frustrated in trying to teach the complexities of our English vocabulary system. There doesn't seem to be enough diversified material to help children and reinforce basic vocabulary skills. This book was created to help meet this challenging task.

The workbook contains four separate units with five lessons to each one. The units are Antonyms, Synonyms, Homophones, and Homographs. Each lesson revolves around a separate core vocabulary given at the beginning. There are various fun-type activities for the child to do such as fill-ins, naming pictures, unscrambling words, crossword puzzles, etc.

The activity worksheets can be used with an individual, small group or an entire classroom. And, when necessary, the sheets may be given as home assignments to reinforce and review lessons.

Hopefully, your students will enjoy learning and practicing vocabulary skills with the fun activities provided in Vocabulary Building.

Jo Ann Gordon

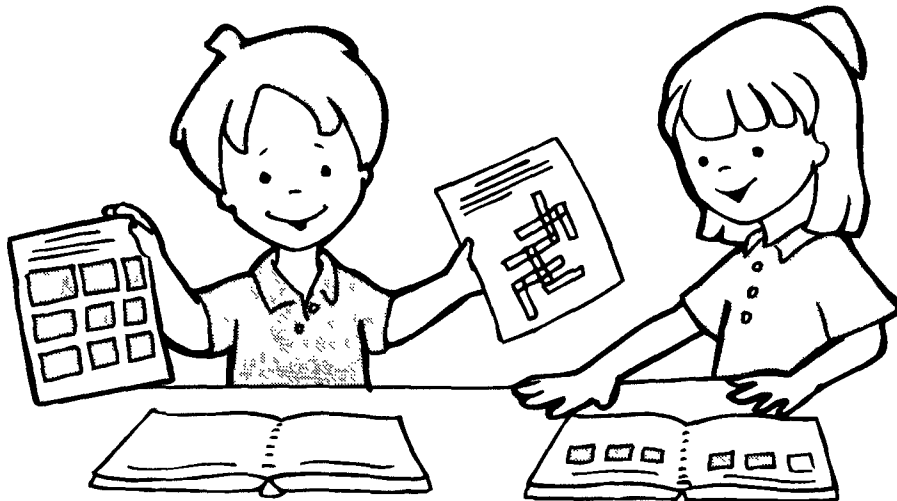

Table of Contents

Antonyms1-40

Lesson 1	1-8
Lesson 2	9-16
Lesson 3	17-24
Lesson 4	25-32
Lesson 5	33-40

Synonyms41-80

Lesson 1	41-48
Lesson 2	49-56
Lesson 3	57-64
Lesson 4	65-72
Lesson 5	73-80

Homophones81-130

Lesson 1	81-90
Lesson 2	91-100
Lesson 3	101-110
Lesson 4	111-120
Lesson 5	121-130

Homographs131-180

Lesson 1	131-140
Lesson 2	141-150
Lesson 3	151-160
Lesson 4	161-170
Lesson 5	171-180

Answer Key181-189



Date: _____

Dear Parent:

Some children have difficulty understanding everyday vocabulary and using it correctly or effectively.

The worksheets your child will bring home are designed to help him/her practice and reinforce everyday, age-appropriate vocabulary.

These worksheets concentrate on practicing and reinforcing _____.

Please check your child's completed home assignment and then sign your name with the date next to it. Thank you for your cooperation.

Sincerely,

Speech-Language Pathologist

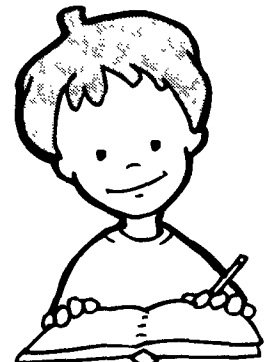
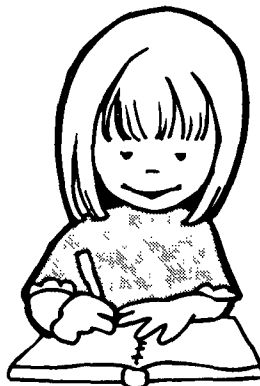
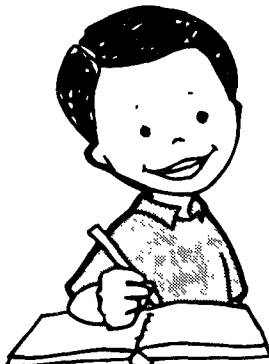

Antonyms

Antonyms are words with opposite meanings.

Instructions – The words in this list show one antonym for each word. Can you name any more antonyms for these words?

- | | |
|----------------------|--------------------------|
| 1. arrive - depart | 7. freeze - thaw |
| 2. comfort - disturb | 8. punish - reward |
| 3. polite - rude | 9. entrance - exit |
| 4. vacant - occupied | 10. valuable - worthless |
| 5. guilty - innocent | 11. comedy - tragedy |
| 6. doctor - patient | 12. bridge - tunnel |

Choose the Correct Antonyms

Instructions – Fill in the blanks in each sentence below with the correct pair of antonyms. Choose from the antonym list below.

arrive - depart
comfort - disturb
polite - rude

vacant - occupied
guilty - innocent
doctor - patient

freeze - thaw
punish - reward
entrance - exit

valuable - worthless
comedy - tragedy
bridge - tunnel

- I promised my dog I wouldn't _____ him, but that I'd _____ him if he did the trick the right way.
- Our plane was set to _____ from the airport in just a few hours, so we had to make sure to _____ at the terminal in time.
- The _____ told the anxious _____ to wait in the waiting room for a little while longer.
- "It's not _____ to stick out your tongue," my mother told my little brother when my sister was _____ to him.
- When my grandpa lost his job, we all tried to _____ him, and we didn't _____ him when he slept late in the morning.
- We didn't put the frozen yogurt back in the freezer to _____; we put it into the refrigerator where it would _____ out a while.
- The prisoner on the T.V. drama was supposed to look mean and _____, but it turned out that he didn't commit the crime and was really _____.
- Mom and I wanted to see a funny _____ at the movies, but my sister and father wanted to see a sad _____ instead.
- The _____ into the museum was on the other side of the _____ out to the street.
- We were happy when we stopped at a motel with one _____ room left, since we were driving all night, and up till then all the motel rooms were _____.
- "Why are you still keeping that piece of junk?" my mom said; "It's not at all _____; it's _____."
- To get to our country cottage, we had to go through a long _____ and then over a wooden _____.

Antonyms are words with opposite meanings.

Name _____ Date _____

Which Antonym Is It?

Instructions – Which one is it? Circle the correct antonym for each sentence.

1. Some parents may do this to their child if he or she disobeys the rules.
Answer: reward him/her, punish him/her
2. A person may go to jail if he or she is found to be this.
Answer: innocent, guilty
3. When a nurse gives you medicine to swallow, you may be this.
Answer: a patient, a doctor
4. You should be on the train platform if you want to do this when the train comes.
Answer: arrive, depart
5. You may do this to someone who is upset or sad.
Answer: comfort him/her, disturb him/her
6. If you want to enjoy your dish of ice cream, don't let it sit on the table and do this for too long.
Answer: freeze, thaw
7. You have to find this place in order to get into the restaurant.
Answer: exit, entrance
8. When something is worn out or broken and can't be sold, it is called this.
Answer: valuable, worthless
9. When you say "please", "thank you", or "I'm sorry", you are this.
Answer: rude, polite
10. This could be something terrible that happens to someone or someone's family.
Answer: a comedy, a tragedy
11. An underground or underwater passage is called this.
Answer: a bridge, a tunnel
12. A sign on a restroom door that tells you there is someone inside and you will have to wait your turn is this.
Answer: occupied, vacant

Antonyms are words with opposite meanings.

Name _____ Date _____

Name The Antonyms



Instructions – Look at each set of anytonym - pictures below. Choose the correct antonym for each set from the word list, and write it in the space provided.

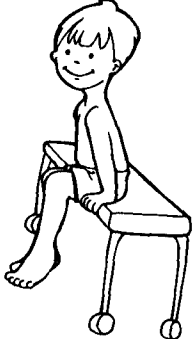

depart
patient

tunnel
freeze

worthless
disturb

 <p>doctor</p>	 <p>_____</p>
---	--

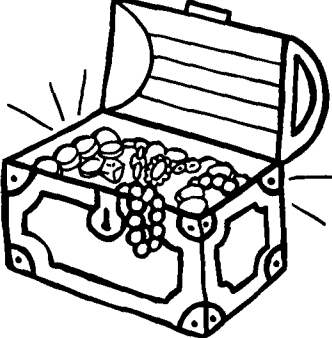
 <p>arrive</p>	 <p>_____</p>
--	--

 <p>valuable</p>	 <p>_____</p>
---	---

Antonyms are words with opposite meanings.

Name _____ Date _____

Name The Antonyms

Instructions – Look at each set of anytonym - pictures below. Choose the correct antonym for each set from the word list, and write it in the space provided.

depart
patient

tunnel
freeze

worthless
disturb

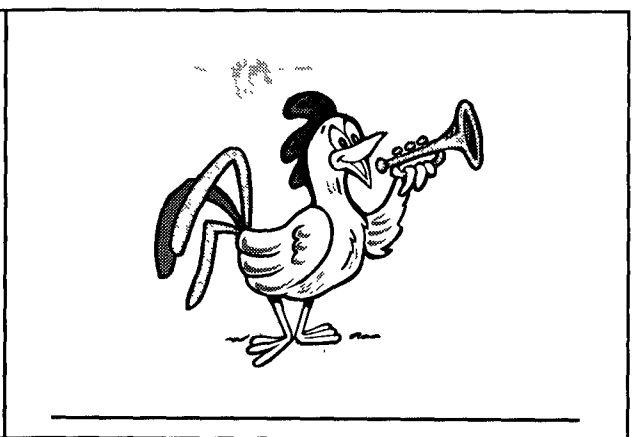
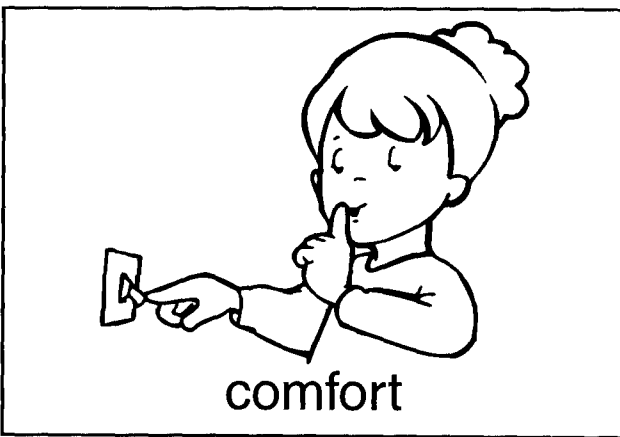
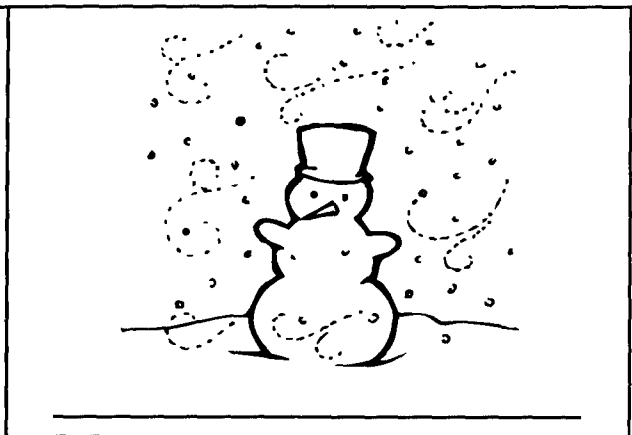
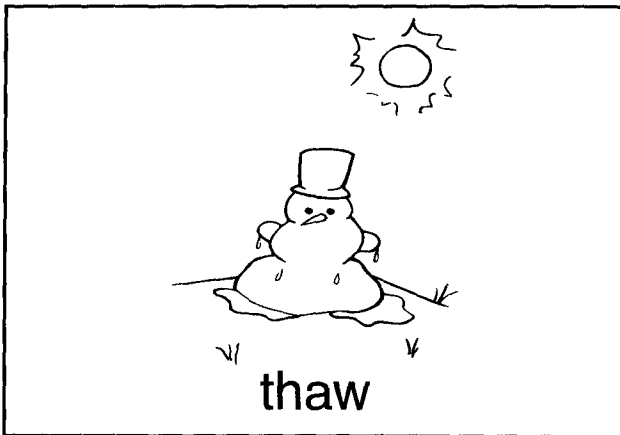
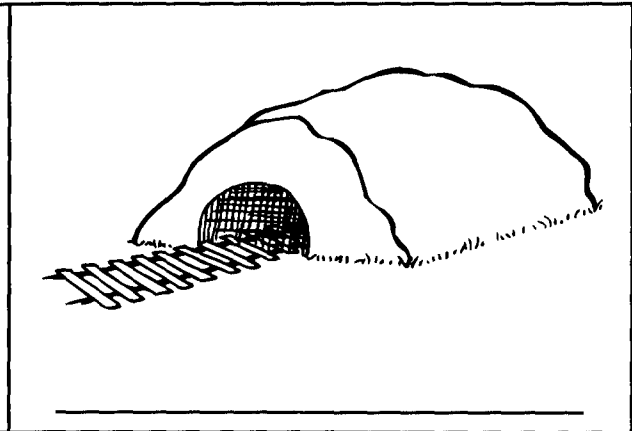
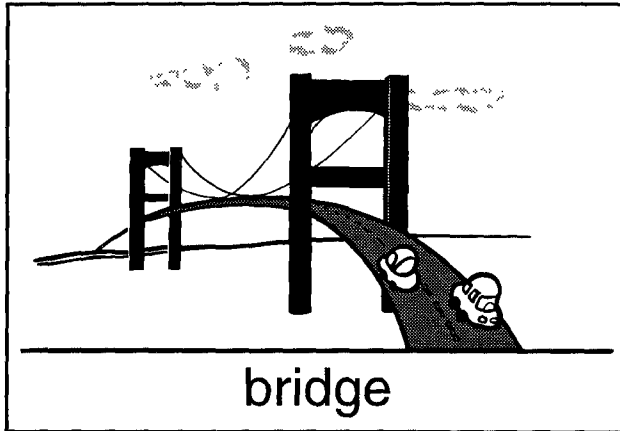

Antonyms are words with opposite meanings.

Name _____ Date _____

Antonyms in Sentences

Instructions – Write sentences using antonyms in the word list below. Write two antonyms in each sentence. You do not have to use all the antonym pairs. You should have ten sentences. Underline the antonyms you use.

arrive - depart
comfort - disturb
polite - rude

vacant - occupied
guilty - innocent
doctor - patient

freeze - thaw
punish - reward
entrance - exit

valuable - worthless
comedy - tragedy
bridge - tunnel

1. _____
2. _____
3. _____
4. _____
5. _____
6. _____
7. _____
8. _____
9. _____
10. _____

Find New Antonyms

The following five words are not shown at the beginning of this lesson. Find antonyms for these five words from the list above. Use the dictionary to help you.

1. leave _____

2. upset _____

3. discourteous _____

4. full _____

5. blameless _____

Antonyms are words with opposite meanings.

Name _____ Date _____

Make Your Own Antonym

Instructions – In the boxes below, draw a picture of your favorite antonym pairs. Write the name of each antonym under each picture.

--	--

--	--

Antonyms are words with opposite meanings.

Name _____ Date _____

Antonym Crossword Puzzle

Instructions – Have fun filling in the crossword puzzle. Each of the answers is an antonym. You may choose your answers from the word list below.

arrive - depart
comfort - disturb
polite - rude

vacant - occupied
guilty - innocent
doctor - patient

freeze - thaw
punish - reward
entrance - exit

valuable - worthless
comedy - tragedy
bridge - tunnel

Across

2. Filled up or lived in
4. To bother or interrupt
6. Without blame
8. Without use or value
10. To make water into ice
11. To give money or a gift for some special service
12. The place where you go out

Down

1. Having correct manners
3. To leave
5. A person who cures you of sickness
7. A funny play or movie
9. To get to the other side of a river, you travel by car over this structure

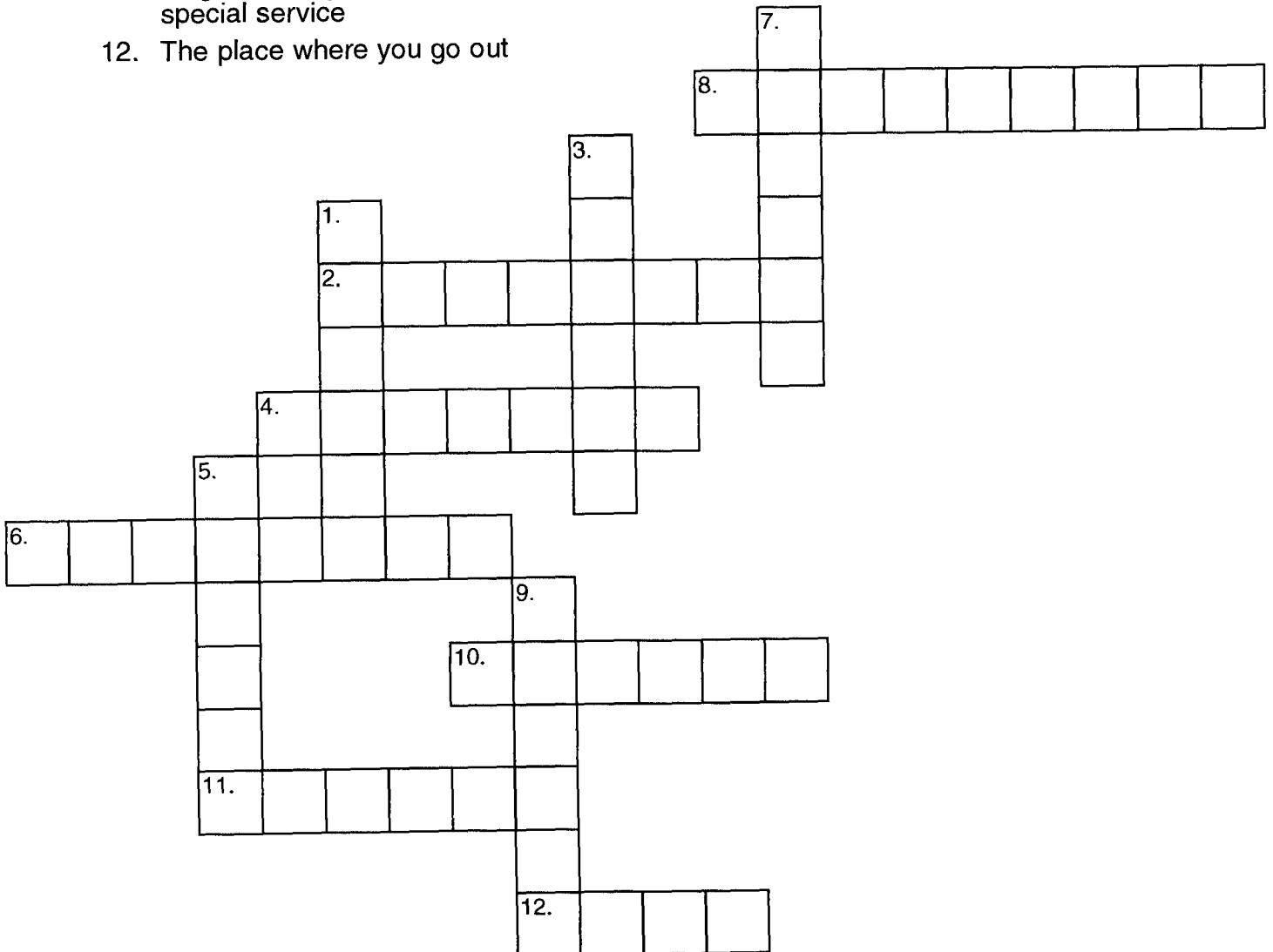

Antonyms are words with opposite meanings.

Name _____ Date _____

Antonyms

Antonyms are words with opposite meanings.

Instructions – The words in this list show one antonym for each word. Can you name any more antonyms for these words?

- | | |
|------------------------|----------------------|
| 1. boss - employee | 7. best - worst |
| 2. break - repair | 8. sweet - sour |
| 3. always - never | 9. niece - nephew |
| 4. increase - decrease | 10. create - destroy |
| 5. fancy - plain | 11. smile - frown |
| 6. most - least | 12. wise - foolish |

Choose the Correct Antonyms

Instructions – Fill in the blanks in each sentence below with the correct pair of antonyms. Choose from the antonym list below.

boss - employee

increase - decrease

best - worst

create - destroy

break - repair

fancy - plain

sweet - sour

smile - frown

always - never

most - least

niece - nephew

wise - foolish

- I didn't mean to _____ my watch, but my dad said that he could _____ it for me.
- My _____ birthday was last year when I had a big party, but my _____ birthday was this year since my friend moved away.
- It was not _____ of me to loan money to that boy, and now I feel _____ because I can't get my money back.
- This year I won't _____ my first science project before I _____ a new one that I like better.
- I have the _____ fun when my friend is home in the summer, but the _____ fun when my friend goes to summer camp.
- My older sister thinks she is too heavy and wants to _____ her weight, while I think I'm too thin and I want to _____ my weight.
- I _____ write in my journal every night, but I _____ let anyone read it but me.
- My cousin said she didn't want a _____ wedding, just something _____ and simple.
- After I dropped the vase and broke it, I had a big, silly _____ on my face; but my mother had a big _____ on her face.
- My father said he was a very happy _____, because he had such a wonderful _____.
- The _____ milk left a bad taste in my mouth, so I ate a _____ cookie to get rid of the taste.
- My aunt says that she doesn't think of us as her _____ and _____, but as her own son and daughter.

Antonyms are words with opposite meanings.

Name _____ Date _____

Which Antonym Is It?

Instructions – Which one is it? Circle the correct antonym for each sentence.

1. A person who works for others in return for wages is this.
Answer: a boss, an employee
2. When you take money out of the bank or your savings, you do this.
Answer: increase the amount of money, decrease the amount of money
3. He had more jellybeans than his friend, so he had this.
Answer: the least, the most
4. When my sister played the part of a showgirl in a play, she needed this kind of costume.
Answer: plain, fancy
5. To mend something you do this to it.
Answer: repair it, break it
6. When you do something stupid, you might feel like this.
Answer: wise, foolish
7. Things made from sugar always taste like this.
Answer: sour, sweet
8. When you are angry at someone, your face may have this on it.
Answer: a smile, a frown
9. When you make something original you do this.
Answer: create it, destroy it
10. Your brother is this to your aunt.
Answer: a niece, a nephew
11. This means at no time or not ever.
Answer: always, never
12. When you try to do a job as good as or better than the rest, you are doing this.
Answer: your best, your worst

Antonyms are words with opposite meanings.

Name _____ Date _____



Name The Antonyms

Instructions – Look at each set of anytonym - pictures below. Choose the correct antonym for each set from the word list, and write it in the space provided.



repair
destroy

smile
decrease

sour
plain

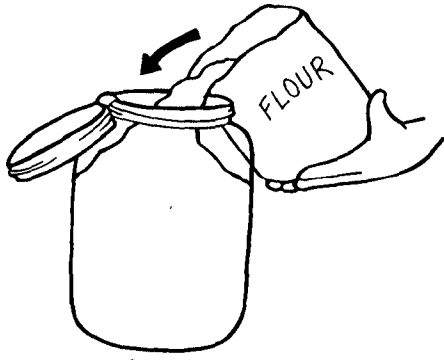
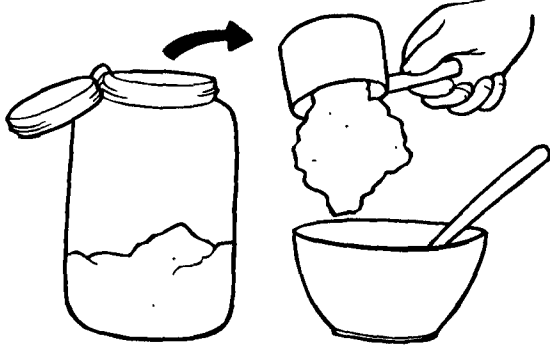
 <p>break</p>	 <p>_____</p>
--	---

 <p>increase</p>	 <p>_____</p>
--	--

 <p>sweet</p>	 <p>_____</p>
--	--

Antonyms are words with opposite meanings.

Name _____ Date _____

Name The Antonyms

Instructions – Look at each set of anytonym - pictures below. Choose the correct antonym for each set from the word list, and write it in the space provided.

repair
destroy

smile
decrease

sour
plain

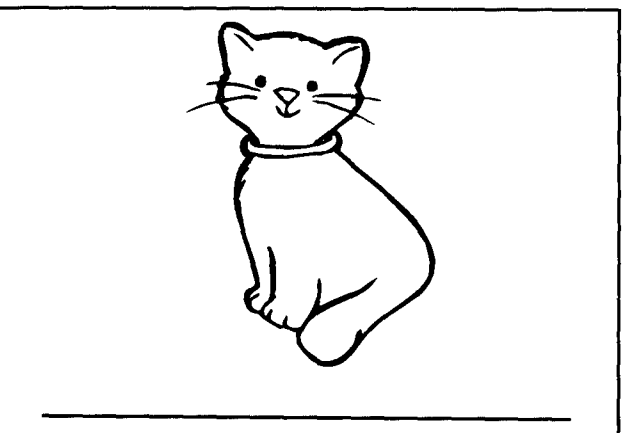
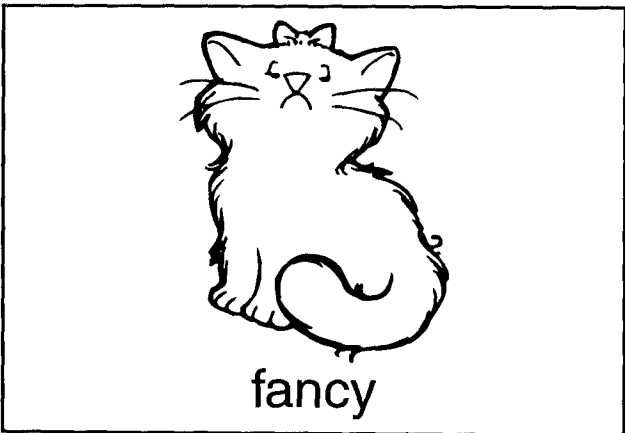
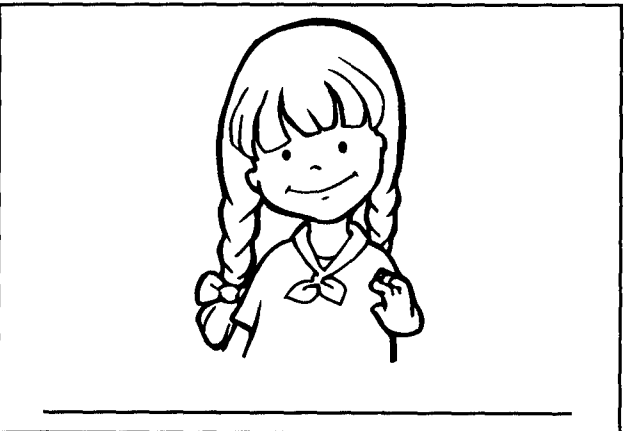
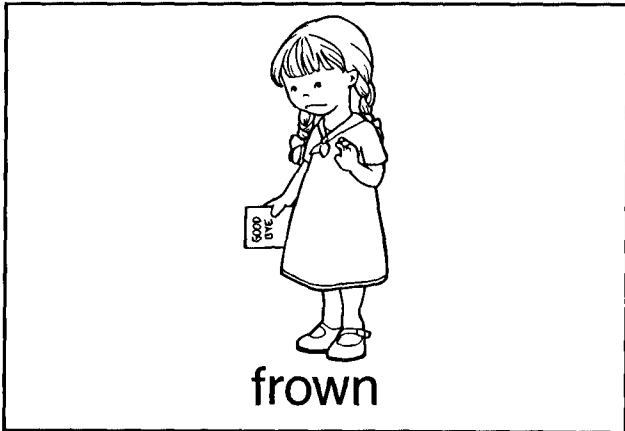
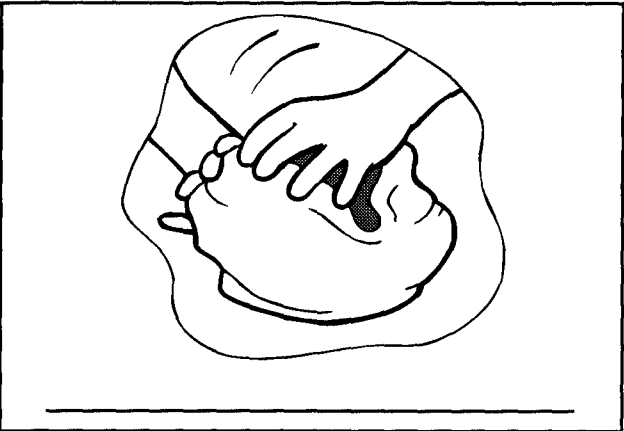
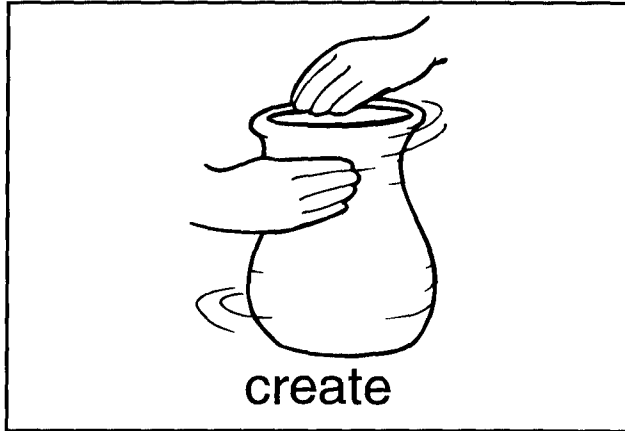

Antonyms are words with opposite meanings.

Name _____ Date _____

Antonyms in Sentences

Instructions – Write sentences using antonyms in the word list below. Write two antonyms in each sentence. You do not have to use all the antonym pairs. You should have ten sentences. Underline the antonyms you use.

- | | | | |
|-----------------|---------------------|----------------|------------------|
| boss - employee | increase - decrease | best - worst | create - destroy |
| break - repair | fancy - plain | sweet - sour | smile - frown |
| always - never | most - least | niece - nephew | wise - foolish |

1. _____
2. _____
3. _____
4. _____
5. _____
6. _____
7. _____
8. _____
9. _____
10. _____

Find New Antonyms

The following five words are not shown at the beginning of this lesson. Find antonyms for these five words from the list above. Use the dictionary to help you.

1. mend _____
2. rarely _____
3. worker _____
4. simple _____
5. lessen _____

Antonyms are words with opposite meanings.

Name _____ Date _____

Make Your Own Antonym

Instructions – In the boxes below, draw a picture of your favorite antonym pairs. Write the name of each antonym under each picture.

--	--

--	--

Antonyms are words with opposite meanings.

Name _____ Date _____

Antonym Crossword Puzzle

Instructions – Have fun filling in the crossword puzzle. Each of the answers is an antonym. You may choose your answers from the word list below.

boss - employee
break - repair
always - never

increase - decrease
fancy - plain
most - least

best - worst
sweet - sour
niece - nephew

create - destroy
smile - frown
wise - foolish

Across

1. To construct or make
3. When your mouth curves upward
5. A person who gets paid for working for others
8. A very smart person
10. What a girl is to her aunt or uncle
12. Less than all the others

Down

2. Again and again or all the time
4. Very simple or easy to understand
6. To make less
7. To fix something
9. The pleasant taste of cookies, cake or ice cream
11. Better than the rest

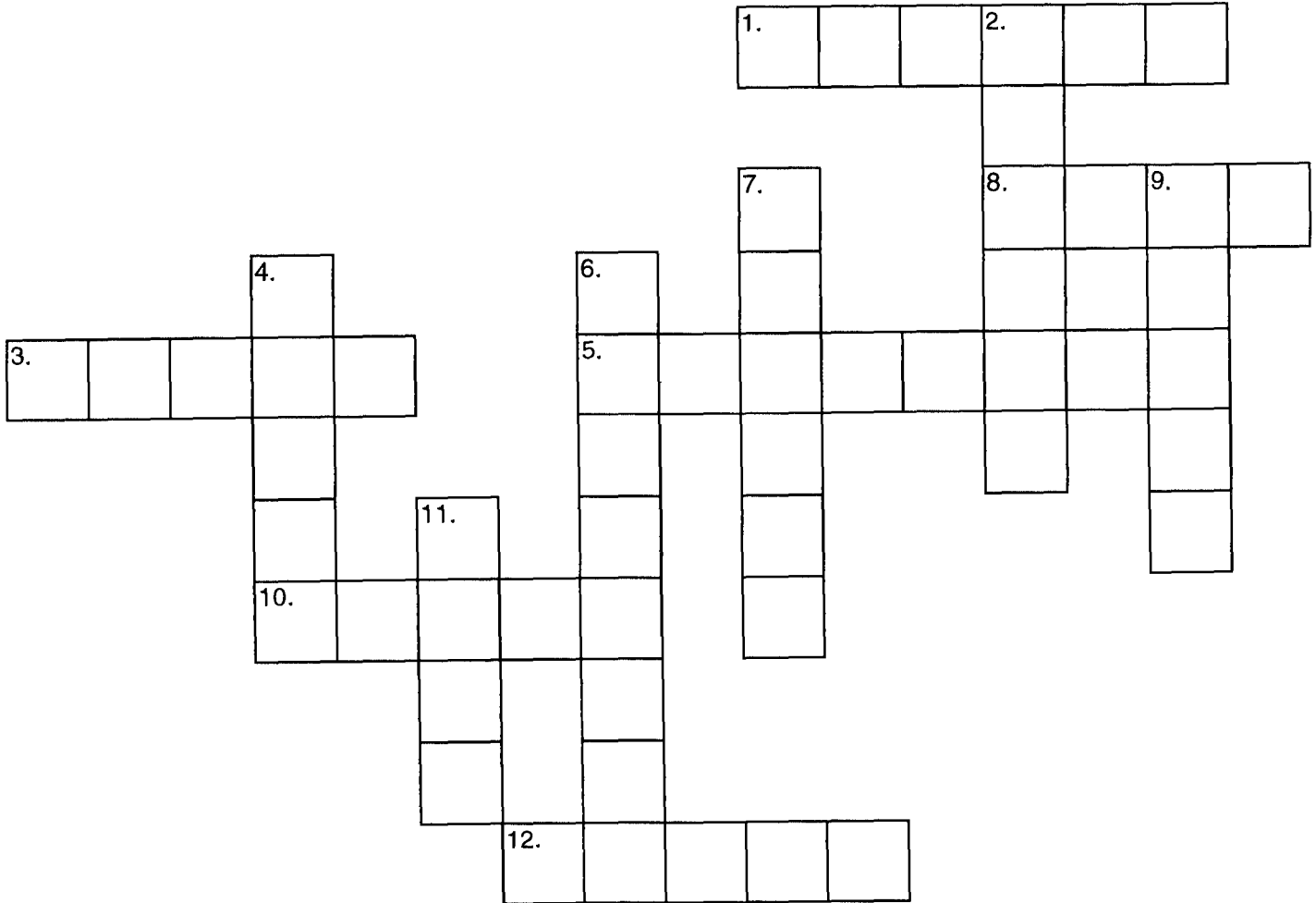

Antonyms are words with opposite meanings.

Name _____ Date _____

Antonyms

Antonyms are words with opposite meanings.

Instructions – The words in this list show one antonym for each word. Can you name any more antonyms for these words?

- | | |
|-----------------------|------------------------|
| 1. many - few | 7. trust - doubt |
| 2. easy - difficult | 8. fresh - stale |
| 3. fat - skinny | 9. similar - different |
| 4. unusual - ordinary | 10. city - country |
| 5. graceful - awkward | 11. all - none |
| 6. silly - serious | 12. raw - cooked |

Choose the Correct Antonyms

Instructions – Fill in the blanks in each sentence below with the correct pair of antonyms. Choose from the antonym list below.

many - few
easy - difficult
fat - skinny

unusual - ordinary
graceful - awkward
silly - serious

trust - doubt
fresh - stale
similar - different

city - country
all - none
raw - cooked

- Even though the trick looked _____ to do, the magician said it was _____ to learn and took a lot of time.
- In the movie, the spaceman looked like an _____ person, but then he began to speak in an _____ language.
- My mom said, "I _____ that you can do the job, but I _____ that you can finish it before bedtime."
- It was a funny sight to see the _____ clown try to squeeze through the narrow window, while the _____ clown tried to pull him out.
- I missed the trees and green grass of the _____ while I spent the summer surrounded by the tall buildings and concrete in the _____.
- Some people say that _____ meat is good for you, but most people like their meat _____.
- The air in the unused cabin smelled _____, so we opened all the windows to let in some _____ air.
- Whenever my sister has a _____ problem in school, she acts _____ and no one suspects she has a real problem.
- _____ people promised that they would show up for the rally, but only a _____ actually came.
- I felt very _____ and clumsy when my _____ friend tried to teach me the new dance she learned.
- My best friend and I wear _____ types of clothes, but we like _____ things to eat.
- I looked forward to eating _____ my Halloween candy, but when I looked for it the next morning there was _____ left.

Antonyms are words with opposite meanings.

Name _____ Date _____

Which Antonym Is It?

Instructions – Which one is it? Circle the correct antonym for each sentence.

1. When there is a lot of something, there is this.
Answer: few, many
2. When you see something you don't see often or hardly at all, it is this.
Answer: ordinary, unusual
3. When a problem is hard to solve, it is this.
Answer: easy, difficult
4. When you can't do something skillfully at first, you may feel like this.
Answer: graceful, awkward
5. When you act stupid or foolish on purpose, you are called this.
Answer: serious, silly
6. If you are very thin, you are this.
Answer: skinny, fat
7. When you don't believe something or someone, you do this.
Answer: trust, doubt
8. When something is uncooked, it is this.
Answer: raw, cooked
9. Everything is the same as this.
Answer: none, all
10. This is a place with many buildings close together and where many people come to work everyday.
Answer: country, city
11. Two things that look almost the same are this.
Answer: different, similar
12. Something that has lost its freshness and tastes flat or dry is this.
Answer: fresh, stale

Antonyms are words with opposite meanings.

Name _____ Date _____

Name The Antonyms

Instructions – Look at each set of anytonym - pictures below. Choose the correct antonym for each set from the word list, and write it in the space provided.

different
difficult

many
cooked

skinny
unusual

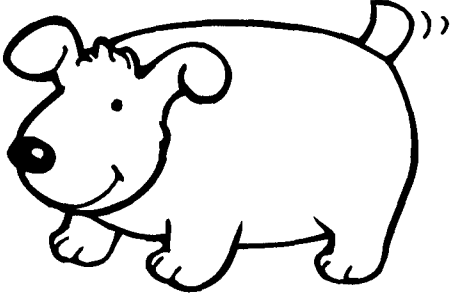

fat



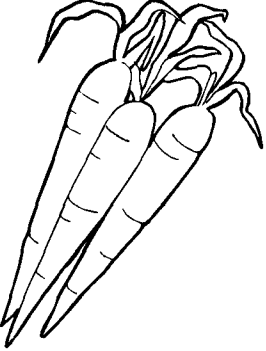

raw

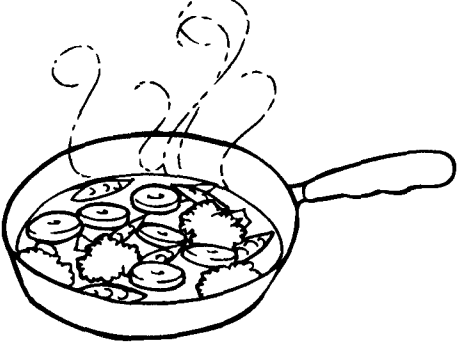

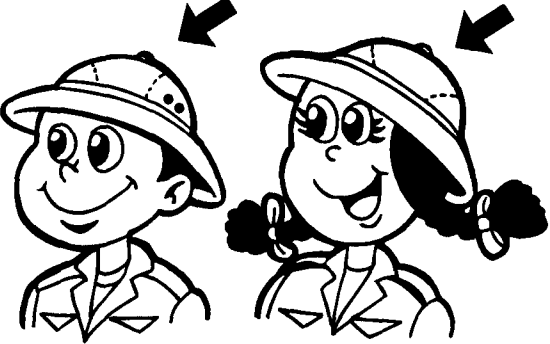

similar

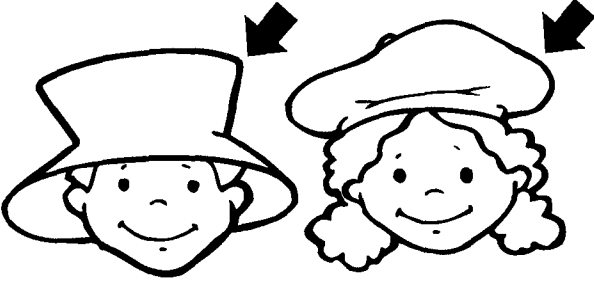

Antonyms are words with opposite meanings.

Name _____ Date _____

Name The Antonyms

Instructions – Look at each set of anytonym - pictures below. Choose the correct antonym for each set from the word list, and write it in the space provided.

different
difficult

many
cooked

skinny
unusual

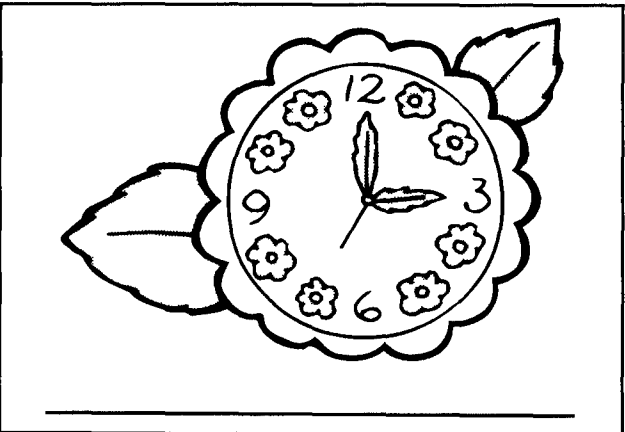
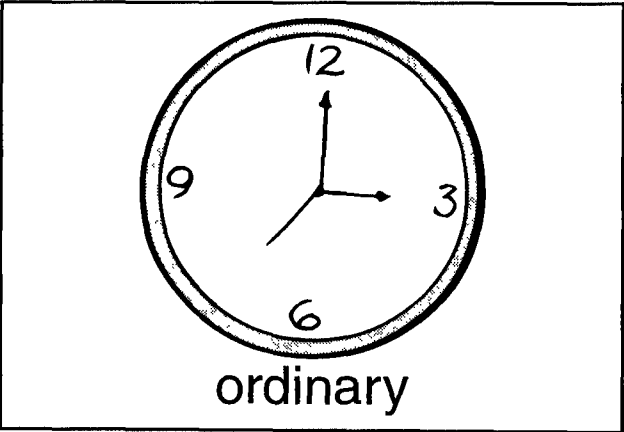
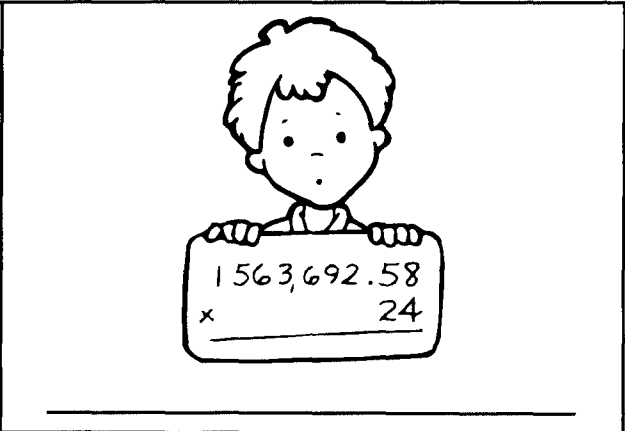
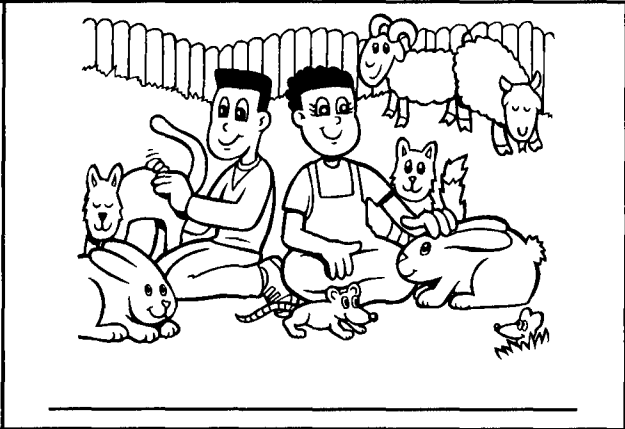
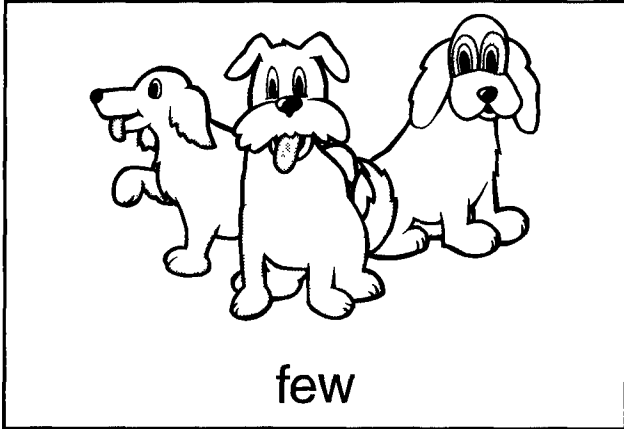

Antonyms are words with opposite meanings.

Name _____ Date _____

Antonyms in Sentences

Instructions – Write sentences using antonyms in the word list below. Write two antonyms in each sentence. You do not have to use all the antonym pairs. You should have ten sentences. Underline the antonyms you use.

many - few

unusual - ordinary

trust - doubt

city - country

easy - difficult

graceful - awkward

fresh - stale

all - none

fat - skinny

silly - serious

similar - different

raw - cooked

1. _____
2. _____
3. _____
4. _____
5. _____
6. _____
7. _____
8. _____
9. _____
10. _____

Find New Antonyms

The following five words are not shown at the beginning of this lesson. Find antonyms for these five words from the list above. Use the dictionary to help you.

1. several _____

2. hard _____

3. slim _____

4. common _____

5. clumsy _____

Antonyms are words with opposite meanings.

Name _____ Date _____

Make Your Own Antonym

Instructions – In the boxes below, draw a picture of your favorite antonym pairs. Write the name of each antonym under each picture.

--	--

--	--

Antonyms are words with opposite meanings.

Name _____ Date _____

Antonym Crossword Puzzle

Instructions – Have fun filling in the crossword puzzle. Each of the answers is a antonym.
 You may choose your answers from the word list below.

many - few
 easy - difficult
 fat - skinny

unusual - ordinary
 graceful - awkward
 silly - serious

trust - doubt
 fresh - stale
 similar - different

city - country
 all - none
 raw - cooked

Across

1. Opposite of clumsy
3. To believe in someone
4. Very thin or very lean
7. Simple to do
8. More than a few
10. Almost alike
12. Flat or dry food that doesn't taste good

Down

2. A big town with many buildings where people often come to work
5. Being foolish on purpose
6. Strange or odd
9. Meat not cooked
11. Everything

1.					2.					
		5			3		6.			
4.										
		9.				7.				
8										
					10.					11.
						12.				

Antonyms are words with opposite meanings.

Name _____ Date _____

Antonyms

Antonyms are words with opposite meanings.

Instructions – The words in this list show one antonym for each word. Can you name any more antonyms for these words?

1. insult - praise
2. friend - enemy
3. give - receive
4. interested - bored
5. teacher - student
6. dim - bright

7. villain - hero
8. public - private
9. fact - fiction
10. famous - unknown
11. absent - present
12. majority - minority

Choose the Correct Antonyms

Instructions – Fill in the blanks in each sentence below with the correct pair of antonyms. Choose from the antonym list below.

insult - praise
friend - enemy
give - receive

interested - bored
teacher - student
dim - bright

villain - hero
public - private
fact - fiction

famous - unknown
absent - present
majority - minority

1. My mother says I don't have to _____ her anything for her birthday, but I know she'll be disappointed if she doesn't _____ anything from me.
2. I always like to be _____ in school when we have Field Day, but this year I was sick and had to be _____.
3. The _____ of the class voted for me for class president, while a _____ voted for Lisa.
4. I know for a _____ that my friend got her idea for the plot of her play from a _____ book she just read.
5. Mrs. Rogers always reminds me that she is the _____ and I am the _____, when I question her directions.
6. I needed a new _____ light in my reading lamp because my old one was much too _____ to read by without getting eye strain.
7. My neighbor down the block was _____ about a year ago and now she's a _____ T.V. star.
8. The _____ in the story was mean looking and wore black all the time, while the _____ was always smiling and wore white all the time.
9. My message to my mother was a _____ one, so I didn't want to use the _____ telephone in full view of everyone.
10. My remark to my friend was supposed to be _____, but she said it sounded like an _____.
11. I tried to look _____ when the speaker began his lecture, but I was really so _____.
12. I used to think that popular boy was my _____, but he turned out to be my best _____.

Antonyms are words with opposite meanings.

Name _____ Date _____

Which Antonym Is It?

Instructions – Which one is it? Circle the correct antonym for each sentence.

1. This is someone you like to be with.
Answer: an enemy, a friend
2. You don't enjoy hearing this said by someone to you.
Answer: praise , an insult
3. This person seeks to learn from someone with more knowledge.
Answer: a teacher, a student
4. When you are not interested, you may feel like this.
Answer: bored, interested
5. The person that everyone hates in a play is this.
Answer: a villain, a hero
6. When the light in a room is low, it is this.
Answer: bright, dim
7. When you accept a gift or a letter from someone, you do this.
Answer: give it, receive it
8. When only some people in a community can use a pool or a club, it is because the pool or club is this.
Answer: public, private
9. When a person is known or recognized by people all over the country or the world, he or she is this.
Answer: unknown, famous
10. A group of people or things that number less than half the total is called this.
Answer: the majority, the minority
11. When you are there and not in another place, you are this.
Answer: present, absent
12. These true statements are called this.
Answer: fiction, facts

Antonyms are words with opposite meanings.

Name _____ Date _____

Name The Antonyms

Instructions – Look at each set of anytonym - pictures below. Choose the correct antonym for each set from the word list, and write it in the space provided.

present
student

villain
bright

private
receive

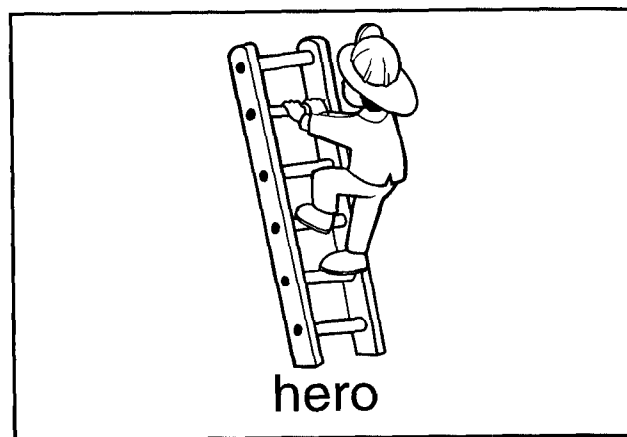
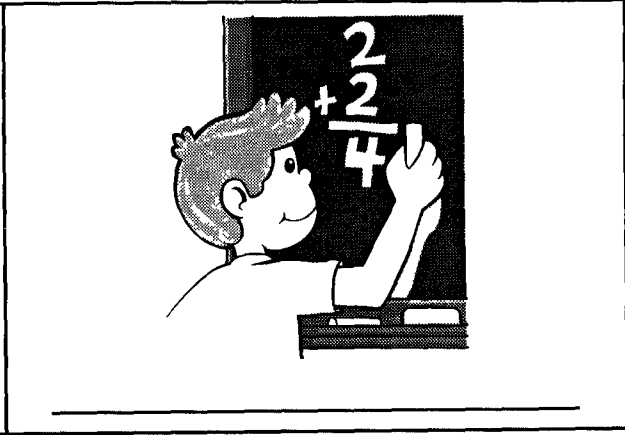
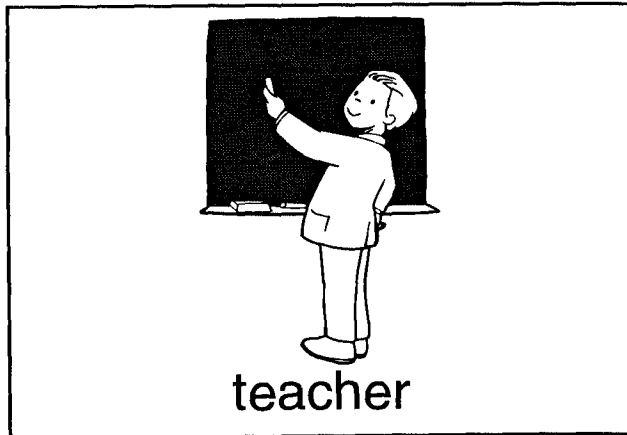
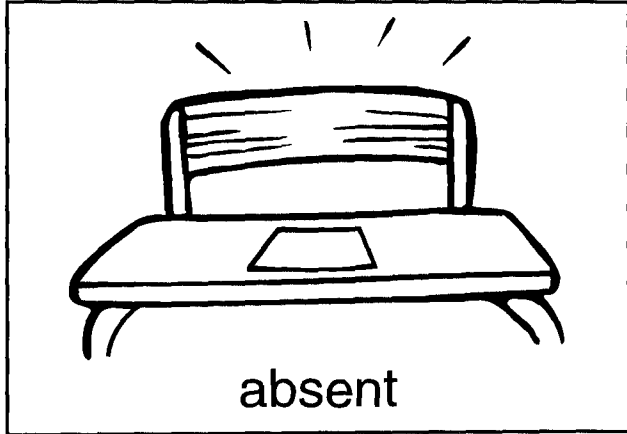

Antonyms are words with opposite meanings.

Name _____ Date _____

Name The Antonyms

Instructions – Look at each set of anytonym - pictures below. Choose the correct antonym for each set from the word list, and write it in the space provided.

present
student

villain
bright

private
receive

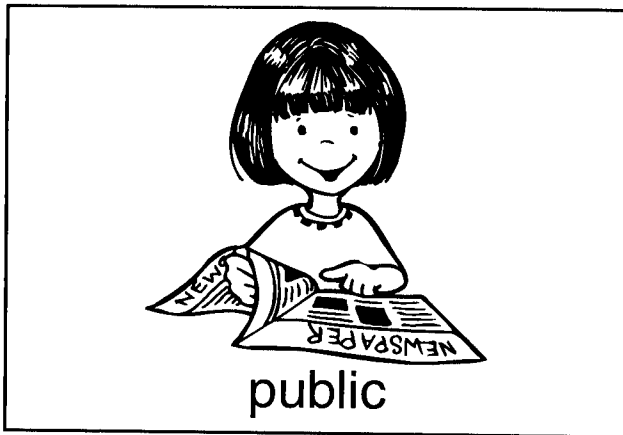
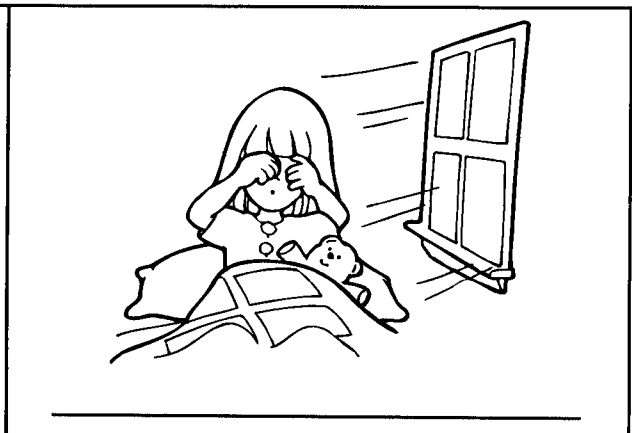
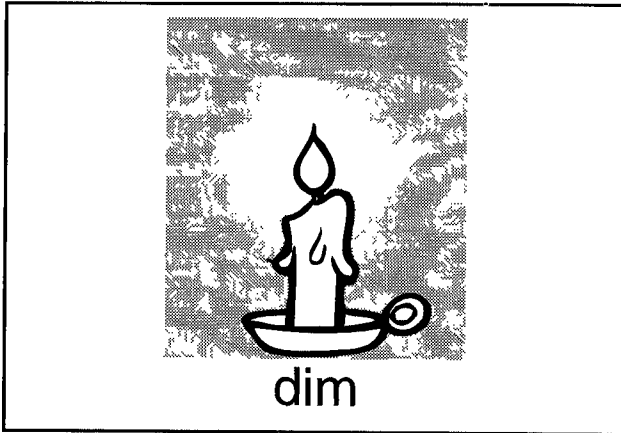
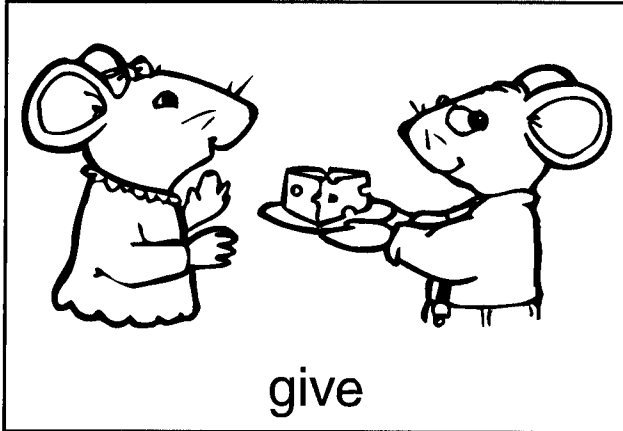

Antonyms are words with opposite meanings.

Name _____ Date _____

Antonyms in Sentences

Instructions – Write sentences using antonyms in the word list below. Write two antonyms in each sentence. You do not have to use all the antonym pairs. You should have ten sentences. Underline the antonyms you use.

insult - praise
friend - enemy
give - receive

interested - bored
teacher - student
dim - bright

villain - hero
public - private
fact - fiction

famous - unknown
absent - present
majority - minority

1. _____
2. _____
3. _____
4. _____
5. _____
6. _____
7. _____
8. _____
9. _____
10. _____

Find New Antonyms

The following five words are not shown at the beginning of this lesson. Find antonyms for these five words from the list above. Use the dictionary to help you.

1. pupil _____

2. indifferent _____

3. obtain _____

4. foe _____

5. flatter _____

Antonyms are words with opposite meanings.

Name _____ Date _____

Make Your Own Antonym

Instructions – In the boxes below, draw a picture of your favorite antonym pairs. Write the name of each antonym under each picture.

--	--

--	--

Antonyms are words with opposite meanings.

Name _____ Date _____

Antonym Crossword Puzzle

Instructions – Have fun filling in the crossword puzzle. Each of the answers is an antonym. You may choose your answers from the word list below.

insult - praise
friend - enemy
give - receive

interested - bored
teacher - student
dim - bright

villain - hero
public - private
fact - fiction

famous - unknown
absent - present
majority - minority

Across

2. To donate or hand over
3. A person who saves someone else from danger
4. To say something unflattering to or about someone
6. A person who learns new things from an instructor
8. A movie or T.V. star is this
9. Someone who is always against you and says bad things about you all the time

Down

1. Less than half the people in a large group
4. To be curious or show concern
5. Not being there
7. Something used by all the people in the community
8. A true statement
10. Not very much light showing

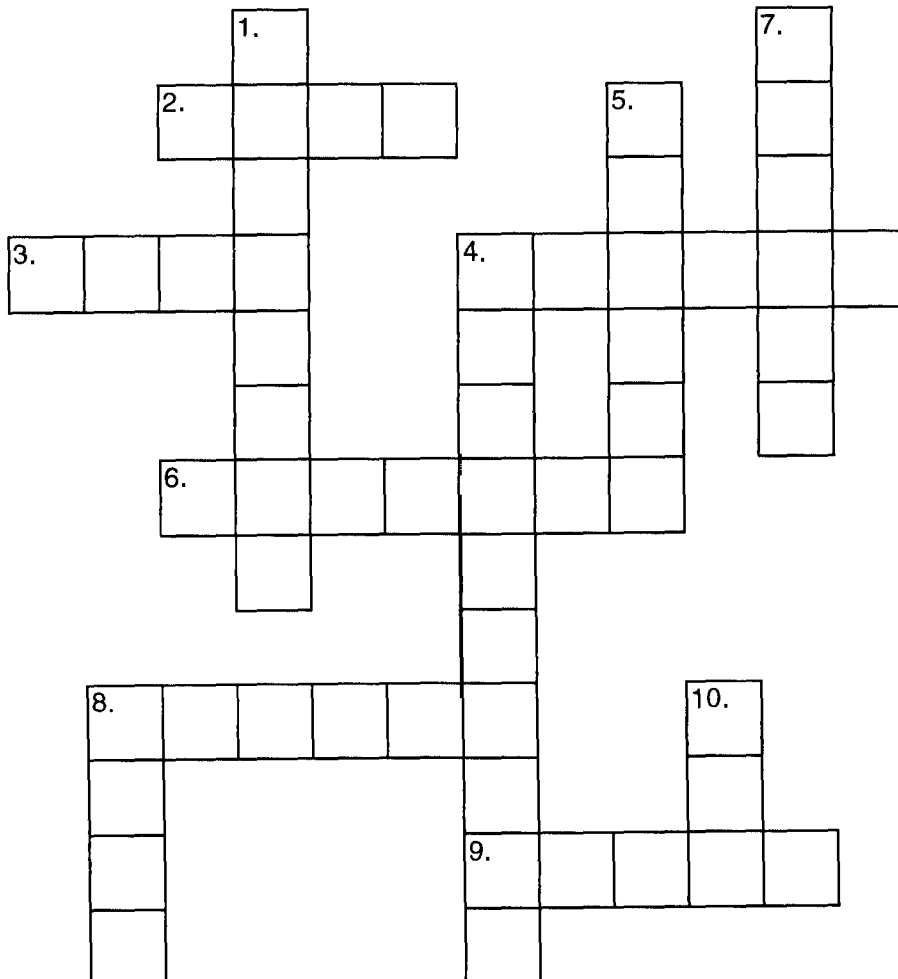

Antonyms are words with opposite meanings.

Name _____ Date _____

Antonyms

Antonyms are words with opposite meanings.

Instructions – The words in this list show one antonym for each word. Can you name any more antonyms for these words?

1. include - exclude
2. sad - cheerful
3. straight - crooked
4. allow - refuse
5. bold - timid
6. past - future

7. notice - ignore
8. part - whole
9. husband - wife
10. kind - cruel
11. safe - dangerous
12. strange - familiar

Choose the Correct Antonyms

Instructions – Fill in the blanks in each sentence below with the correct pair of antonyms. Choose from the antonym list below.

include - exclude

allow - refuse

notice - ignore

kind - cruel

sad - cheerful

bold - timid

part - whole

safe - dangerous

straight - crooked

past - future

husband - wife

strange - familiar

- I know I am supposed to be _____ on my birthday, but my pet hamster just died and I was feeling so _____.
- I tried to pretend I didn't _____ the teacher standing there, but then she said "hello" and I couldn't _____ her.
- You have to be very _____ to jump out of an airplane; I think I am too _____ to ever do that for fun.
- My dog was not _____ with my sister's witch costume, so it was not unusual that he barked at her _____ new appearance.
- In my art lesson I tried to make the road look _____ and narrow, but it came out winding and _____.
- I knew the new girl in class would _____ me from her birthday party guest list since she wanted to _____ only the most popular kids.
- My dad did not _____ me to buy expensive sports equipment, so I knew he would _____ to loan me the money when I asked.
- If the original owner of the dog had been _____ instead of _____ to it, the dog would not be barking and snarling at everyone who tried to pet it.
- My teacher says we can learn from _____ history not to make the same mistakes in the _____.
- I only finished _____ of my project last night since it was too late to complete the _____ thing.
- My older sister is going to be married next week and become a _____; while my uncle will become a _____ in the following month.
- The roads were _____ to ride on because of all the rain, so we waited another day just to be _____.

Antonyms are words with opposite meanings.

Name _____ Date _____

Which Antonym Is It?

Instructions – Which one is it? Circle the correct antonym for each sentence.

1. When you don't want someone to join your club, you do this to him or her.
Answer: include him/her, exclude him/her
2. A curved line is this.
Answer: crooked, straight
3. When you are very happy, you look like this.
Answer: cheerful, sad
4. When you choose not to see something you do this to it.
Answer: ignore it, notice it
5. When you let someone do something to you or for you, you do this.
Answer: allow it, refuse it
6. This event has not happened yet because it is here.
Answer: in the past, in the future
7. When you can only have a piece of something, you get this.
Answer: a whole, a part
8. When you have seen someone or something over and over again and you know it very well, you feel it is this to you.
Answer: strange, familiar
9. A married woman is called this.
Answer: a wife, a husband
10. When something you plan to do might cause you harm, it is called this.
Answer: safe, dangerous
11. When you feel shy or afraid to try something, you may be called this.
Answer: bold, timid
12. When someone is mean or nasty, they are called this.
Answer: kind, cruel

Antonyms are words with opposite meanings.

Name _____ Date _____

Name The Antonyms

Instructions – Look at each set of anytonym - pictures below. Choose the correct antonym for each set from the word list, and write it in the space provided.

dangerous
crooked

part
wife

cheerful
ignore





husband

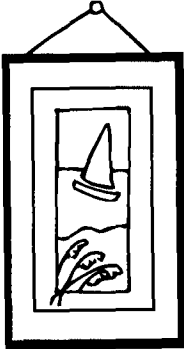

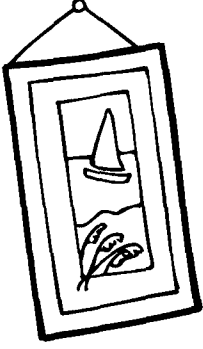

straight





sad



Antonyms are words with opposite meanings.

Name _____ Date _____

Name The Antonyms

Instructions – Look at each set of anytonym - pictures below. Choose the correct antonym for each set from the word list, and write it in the space provided.

dangerous
crooked

part
wife

cheerful
ignore



safe

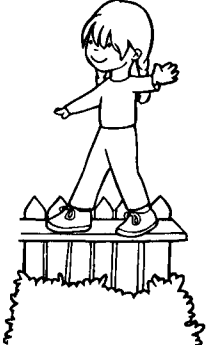



whole

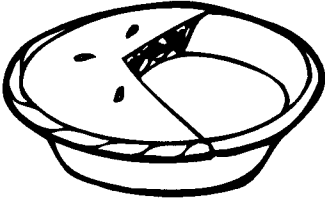

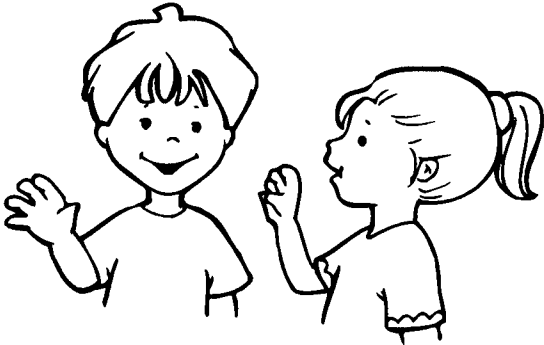

notice

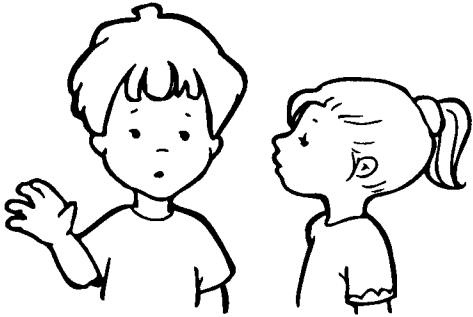

© 1997 Super Duper® Publications 1-800-277-8737

Antonyms are words with opposite meanings.

Name _____ Date _____

Antonyms in Sentences

Instructions – Write sentences using antonyms in the word list below. Write two antonyms in each sentence. You do not have to use all the antonym pairs. You should have ten sentences. Underline the antonyms you use.

include - exclude

allow - refuse

notice - ignore

kind - cruel

sad - cheerful

bold - timid

part - whole

safe - dangerous

straight - crooked

past - future

husband - wife

strange - familiar

1. _____
2. _____
3. _____
4. _____
5. _____
6. _____
7. _____
8. _____
9. _____
10. _____

Find New Antonyms

The following five words are not shown at the beginning of this lesson. Find antonyms for these five words from the list above. Use the dictionary to help you.

1. omit _____

2. happy _____

3. mean _____

4. cowardly _____

5. overlook _____

Antonyms are words with opposite meanings.

Name _____ Date _____

Make Your Own Antonym

Instructions – In the boxes below, draw a picture of your favorite antonym pairs. Write the name of each antonym under each picture.

--	--

--	--

Antonyms are words with opposite meanings.

Name _____ Date _____

Antonym Crossword Puzzle

Instructions – Have fun filling in the crossword puzzle. Each of the answers is an antonym. You may choose your answers from the word list below.

include - exclude
sad - cheerful
straight - crooked

allow - refuse
bold - timid
past - future

notice - ignore
part - whole
husband - wife

kind - cruel
safe - dangerous
strange - familiar

Across

1. To keep someone from entering a place or group
3. Unhurt or free from danger
5. A time that is to come
7. Something that has bends or curves and is not straight
9. Something which is complete, with all its parts
11. To observe or be aware of

Down

2. Happy and glad
4. Decision not to act or do something
6. Fearless and daring
8. A man joined to a woman in marriage
10. To be acquainted with
12. Causing pain or suffering

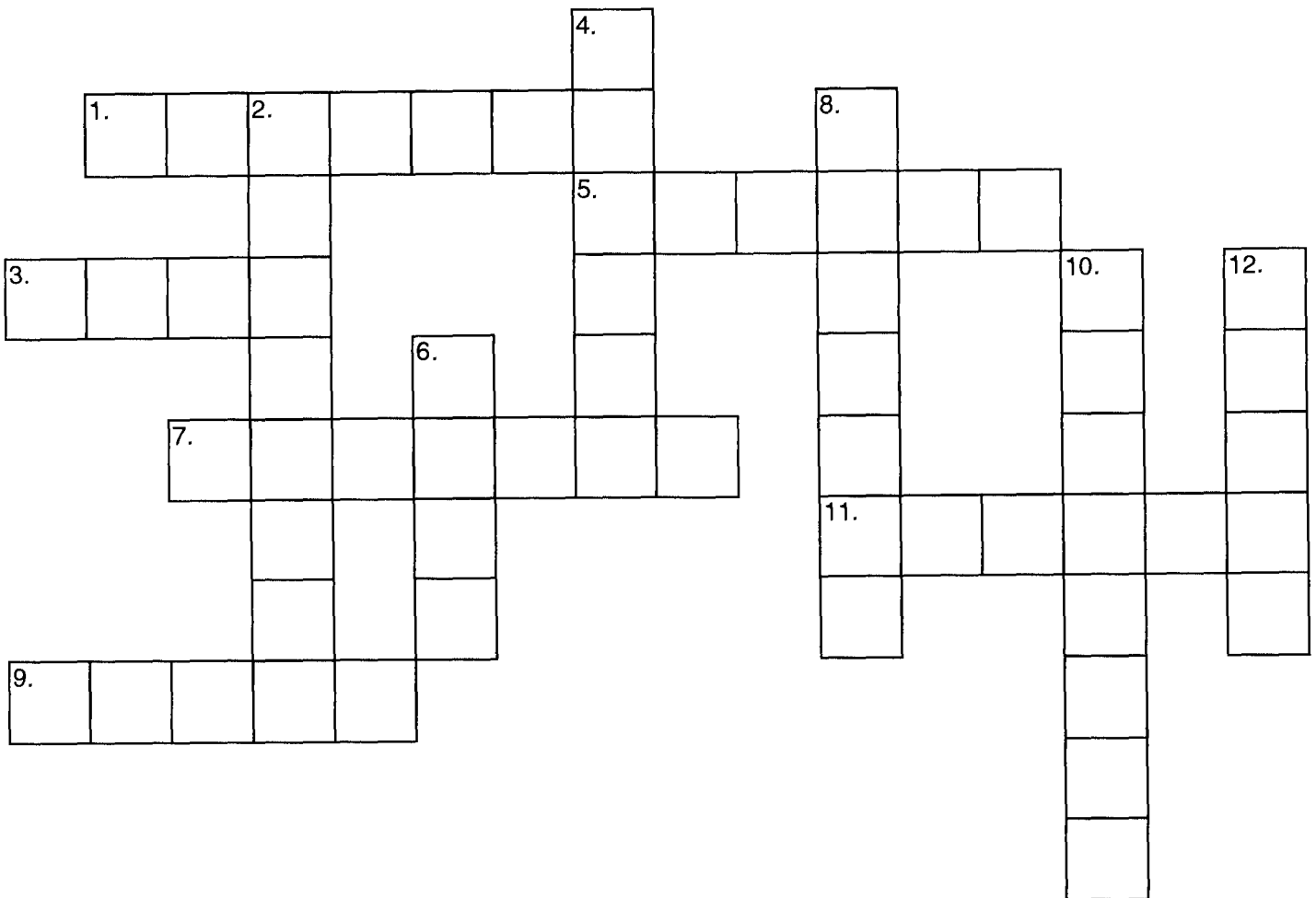

Antonyms are words with opposite meanings.

Name _____ Date _____

Synonyms

Synonyms are words with one or more similar or same meanings.

Instructions – The words in this list show one synonym for each. Yet, you may know more synonyms for each word shown.

- | | |
|-----------------------|-------------------|
| 1. under - beneath | 7. pick - choose |
| 2. chubby - plump | 8. allow - permit |
| 3. friend - companion | 9. ask - request |
| 4. watch - look | 10. near - close |
| 5. champion - winner | 11. pull - drag |
| 6. simple - easy | 12. above - over |

Choose the Correct Synonyms

Instructions – Fill in the blanks in each sentence below with the correct pair of synonyms. Choose from the synonym list below.

under - beneath	watch - look	pick - choose	near - close
chubby - plump	champion - winner	allow - permit	pull - drag
friend - companion	simple - easy	ask - request	above - over

1. Since I was very little, my mom let me _____ my own clothes to wear each day.
2. My cat likes to sit on the window sill and _____ all the people go by.
3. My aunt says her cocker spaniel is her most loyal _____.
4. When the race was over, my best friend Todd was the _____.
5. The cobweb was too high _____ my head for me to brush it away with the broom.
6. The ball rolled _____ the limousine and I couldn't get it back.
7. The juggler told the crowd it was _____ to learn how to juggle if you really wanted to and you practiced a lot.
8. My father won't _____ me to go to the movies on a week night.
9. The telephone message said you had to _____ tickets in a letter to the box office.
10. My baby sister likes to _____ her dollie around by her long, braided hair.
11. My mother says I was a _____ baby with cheeks like a chipmunk.
12. I am lucky I live _____ to my school, so I can walk instead of ride the bus.

Synonyms are words with one or more similar or same meanings.

Name _____ Date _____

Which Synonym Is It?

Instructions – Which one is it? Circle the correct synonym for each sentence.

1. I am someone you spend a lot of time with and you may tell me your secrets.
Answer: a champion, a companion
2. Clouds in the sky are here.
Answer: above us, beneath us
3. A person or animal that eats too much food could become this.
Answer: simple, chubby
4. You have to do this when you must decide between two things.
Answer: choose, watch
5. The marble rolled here.
Answer: beneath the bed, above the bed
6. The dog can't come in the store with you because of this.
Answer: the owner wouldn't watch it, the owner wouldn't allow it
7. If a job doesn't take much time or work, it is this.
Answer: simple, over
8. When you come in first at the spelling bee, you are called this.
Answer: the companion, the champion
9. You must do this if you want to get permission.
Answer: request it, permit it
10. If your friend lives next door to you, he or she is this.
Answer: close to you, under you
11. The store detective has to do this to all customers.
Answer: watch them, drag them
12. You do this to a wagon.
Answer: pull it, permit it

Synonyms are words with one or more similar or same meanings.

Name _____ Date _____

Name The Synonyms

Instructions – Name the synonym pairs in each picture from the word list below. Write your answers under each picture. Color the pictures as you wish.

under - beneath
chubby - plump
friend - companion

pick - choose
ask- request
near - close

pull - drag
above - over
watch - look

champion - winner
simple - easy
allow - permit

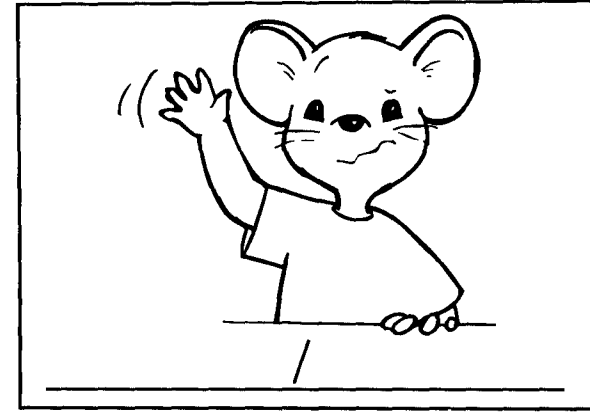
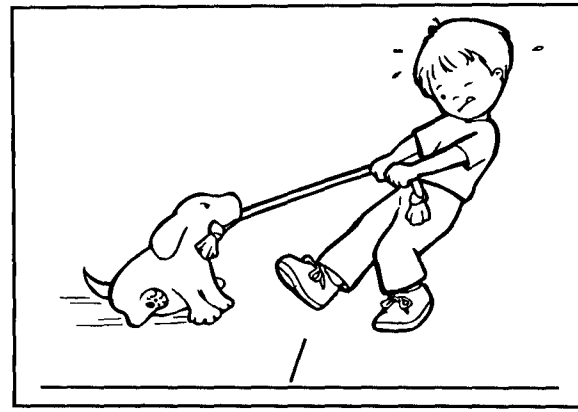
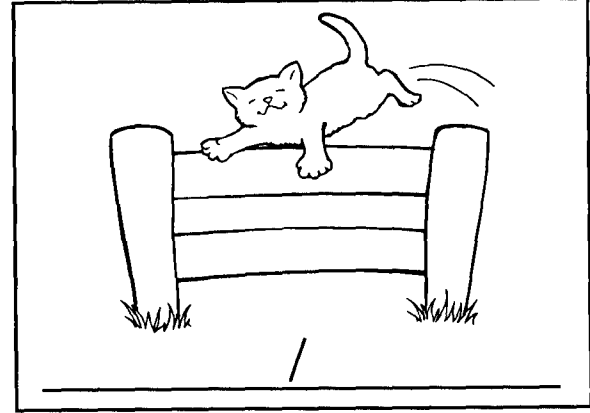
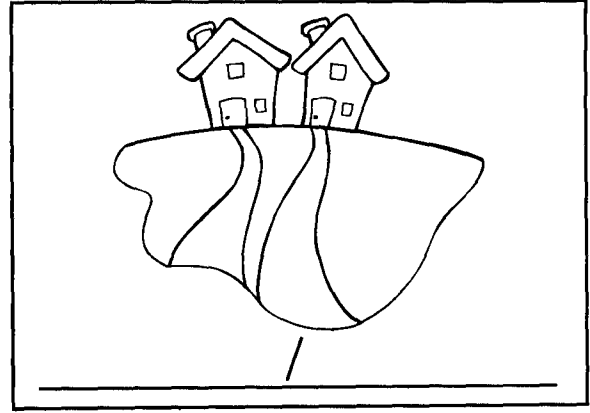
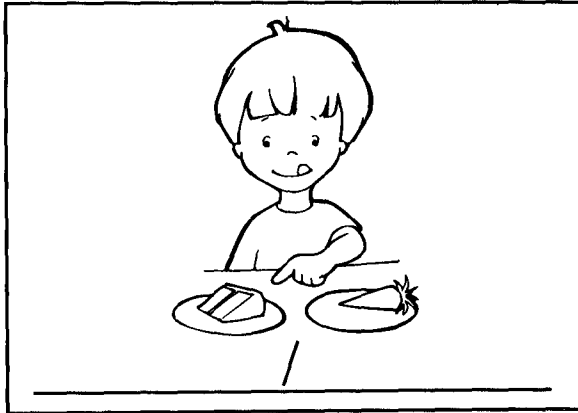

Synonyms are words with one or more similar or same meanings.

Name _____ Date _____

Name The Synonyms

Instructions – Name the synonym pairs in each picture from the word list below. Write your answers under each picture. Color the pictures as you wish.

under - beneath
chubby - plump
friend - companion

pick - choose
ask- request
near - close

pull - drag
above - over
watch - look

champion - winner
simple - easy
allow - permit

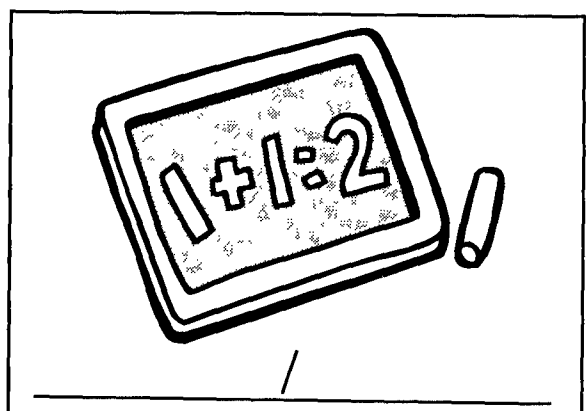
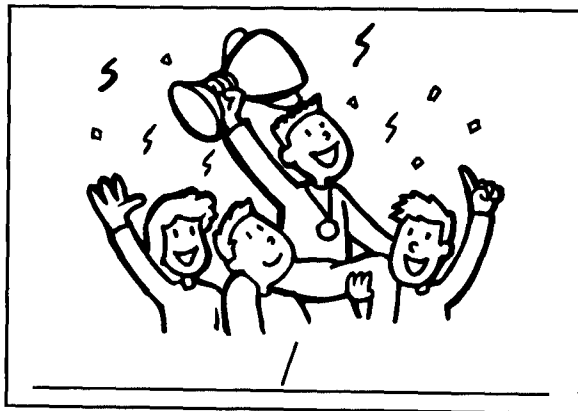
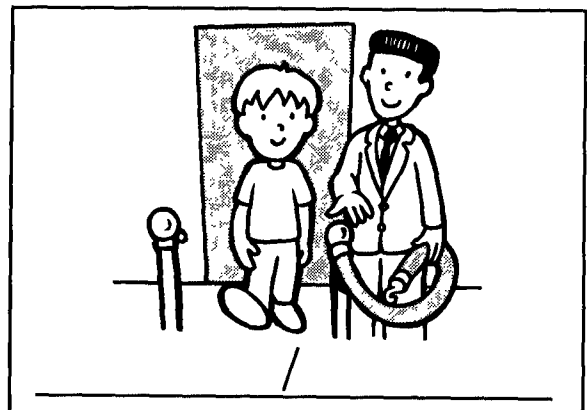
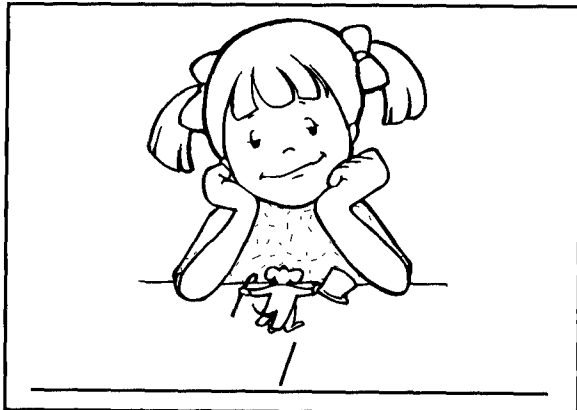
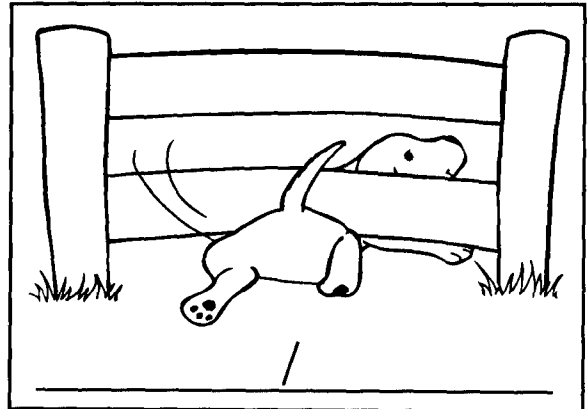
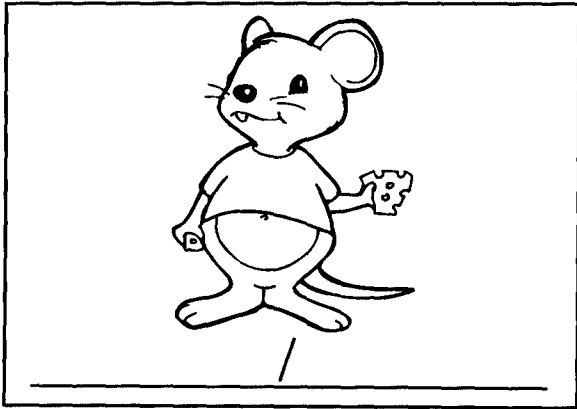

Synonyms are words with one or more similar or same meanings.

Name _____ Date _____

Find the Synonym

Instructions – In the sentence below, one word is underlined. Find a synonym for that underlined word in the list below. Write it in the blank next to the word.

under - beneath

watch - look

pick - choose

near - close

chubby - plump

champion - winner

allow - permit

pull - drag

friend - companion

simple - easy

ask - request

above - over

1. I dropped my wallet over the ledge and it fell below (_____) me into the water.
2. I was sorry I could only select (_____) one appetizer from the many delicious ones on the menu.
3. My pal (_____) Sandy came with me to the dentist after school.
4. The teacher said we had to observe (_____) the magician's hands very closely to see how the trick was done.
5. The vet told my uncle that his overweight (_____) golden retriever needed to go on a diet.

Synonym Scramble

Unscramble these words. Write the correct words in the blanks next to the scrambled words. Then, write a sentence for each unscrambled word in the blanks under the words.

1. thenabe – _____

2. wolal – _____

3. limpes – _____

4. newirn – _____

5. stequer – _____

Synonyms are words with one or more similar or same meanings.

Name _____ Date _____

Make Your Own Synonym

Instructions – In the boxes below, draw a picture of your favorite synonym pairs. Write the name of each synonym under each picture.

--	--

--	--

Synonyms are words with one or more similar or same meanings.

Name _____ Date _____

Synonym Crossword Puzzle

Instructions – Have fun filling in the crossword puzzle. Each of the answers is a synonym.
 You may choose your answers from the word list below.

under - beneath
 chubby - plump
 friend - companion

watch - look
 champion - winner
 simple - easy

pick - choose
 allow - permit
 ask - request

near - close
 pull - drag
 above - over

Across

1. A chum or buddy
3. Not hard to do or understand
5. When you need something, you do this
8. Best or first in a contest
10. Overweight

Down

2. To let
4. Beside you
6. Below
7. Select
8. Observe
9. To drag along
11. Overhead

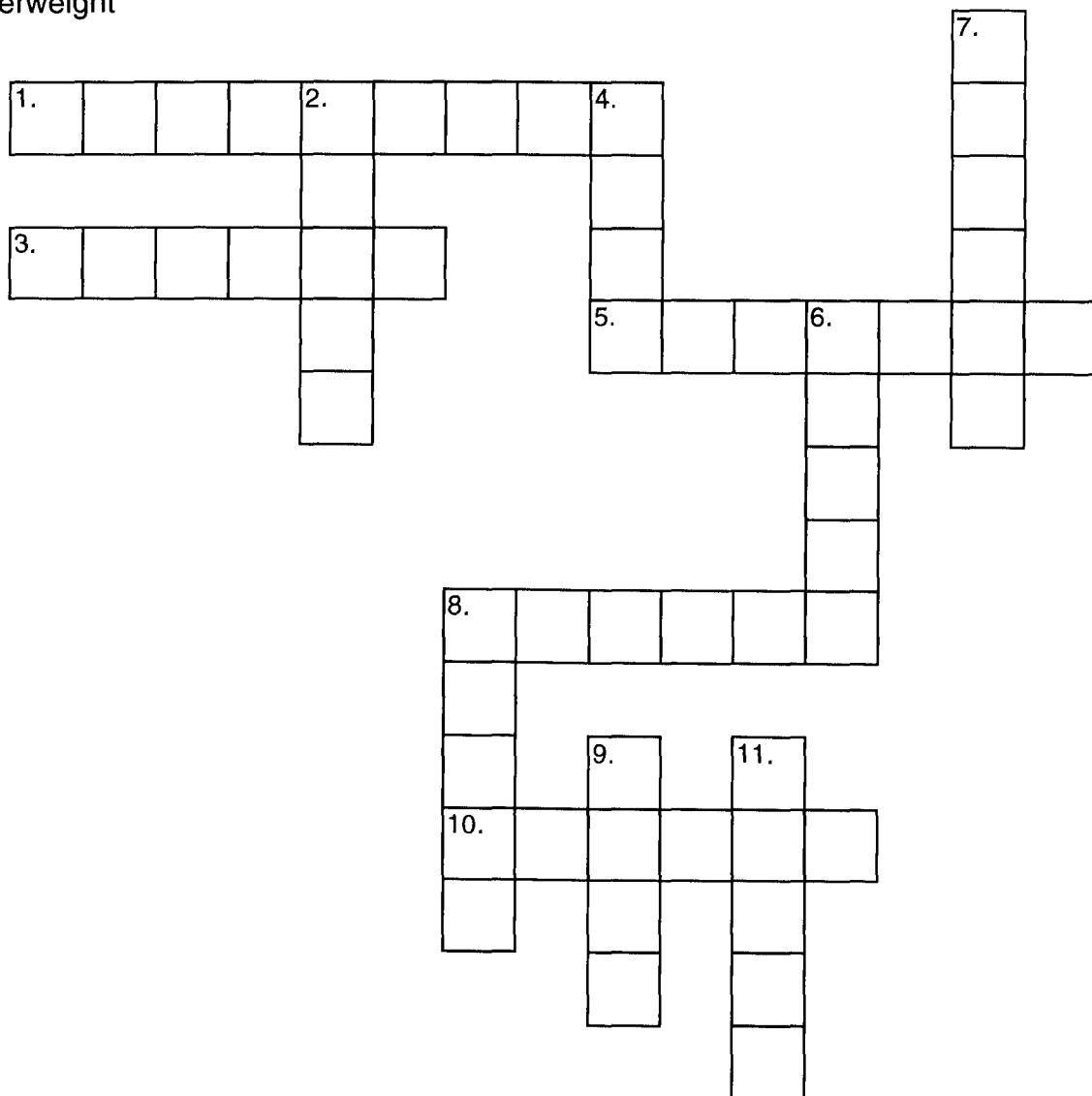

Synonyms are words with one or more similar or same meanings.

Name _____ Date _____

Synonyms

Synonyms are words with one or more similar or same meanings.

Instructions – The words in this list show one synonym for each. Yet, you may know more synonyms for each word shown.

- | | |
|----------------------|------------------------|
| 1. prank - joke | 7. middle - center |
| 2. brave - bold | 8. remain - stay |
| 3. build - construct | 9. belief - opinion |
| 4. name - title | 10. far - distant |
| 5. silly - foolish | 11. vanish - disappear |
| 6. rich - wealthy | 12. find - discover |

Choose the Correct Synonyms

Instructions – Fill in the blanks in each sentence below with the correct pair of synonyms. Choose from the synonym list below.

prank - joke

name - title

middle - center

far - distant

brave - bold

silly - foolish

remain - stay

vanish - disappear

build - construct

rich - wealthy

belief - opinion

find - discover

- When I was very little, I used to _____ buildings and houses with my blocks.
- I can't remember the _____ of the book exactly, but it was one of my favorite books to read.
- The magician said he would make the rabbit _____.
- When I grow up I would like to travel to places very _____ from where I live now.
- The cowboys hoped to _____ gold in the old wild west.
- I had to _____ home and watch my baby sister while my parents went out for a couple of hours.
- Our teacher asked us what our _____ was about the reality of flying saucers.
- When I threw the dart, I knew I had to hit the bulls-eye which was right in the _____ of the circle.
- The fireman was very _____ when he went into the burning building to save the child.
- Every April Fool's Day, my friend Jerry likes to play a _____ on me.
- One day, when I'm _____ I'd like to travel around the world on my own private plane.
- "Don't be _____," my teacher said, "You can't have a day off on ground-hog day."

Synonyms are words with one or more similar or same meanings.

Name _____ Date _____

Which Synonym Is It?

Instructions – Which one is it? Circle the correct synonym for each sentence.

1. If you act like a clown when you shouldn't, people will think you are this.

Answer: wealthy, foolish

2. A construction worker can do this.

Answer: build houses , discover new places

3. This is something you may hold.

Answer: a prank, an opinion

4. Every person has this thing.

Answer: a joke, a name

5. A dog sometimes has to do this in the car when you leave it.

Answer: vanish, remain

6. Police officers and soldiers are often this.

Answer: bold, silly

7. When you have a million dollars, you are this.

Answer: rich, brave

8. You may laugh at this.

Answer: a prank, a center

9. If someone stands in line here, he or she is not in the back or the front because he or she is here.

Answer: in the middle, far away

10. This is the opposite of near.

Answer: distant, middle

11. An explorer would do this.

Answer: discover new countries or places, vanish from sight.

12. If it could become invisible, it can do this.

Answer: disappear, construct

Synonyms are words with one or more similar or same meanings.

Name _____ Date _____

Name The Synonyms

Instructions – Name the synonym pairs in each picture from the word list below. Write your answers under each picture. Color the pictures as you wish.

name - title
 far - distant
 middle - center

prank - joke
 brave - bold
 belief - opinion

build - construct
 rich - wealthy
 find - discover

silly - foolish
 remain - stay
 vanish - disappear

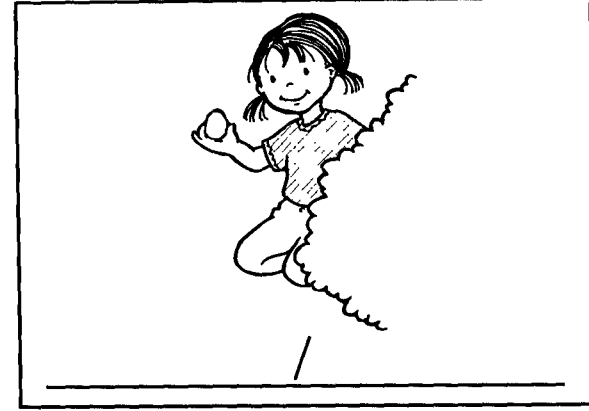
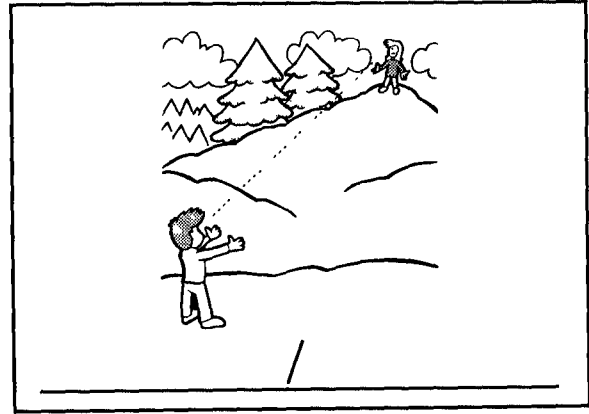
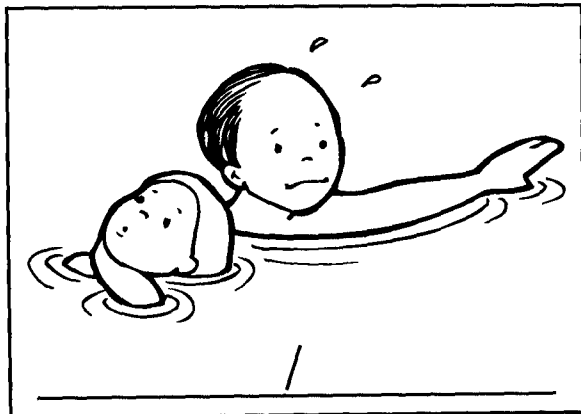
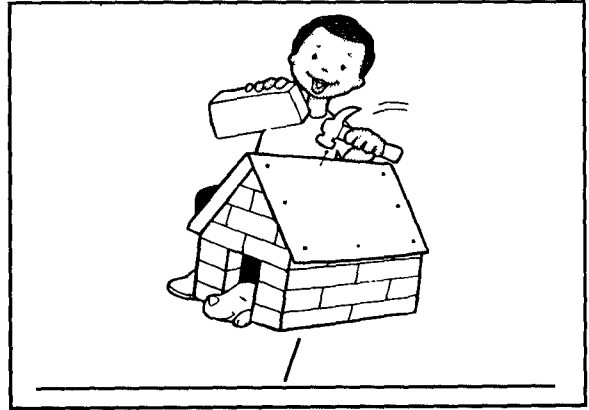
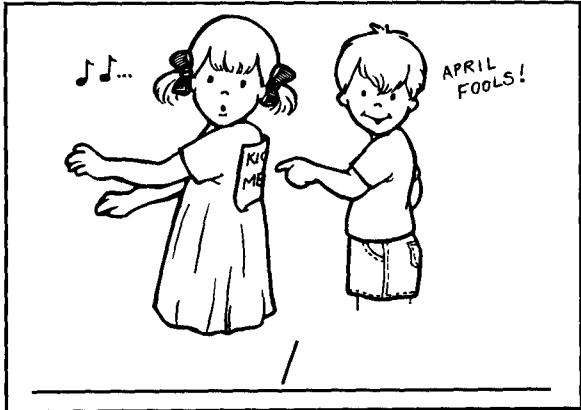

Synonyms are words with one or more similar or same meanings.

Name _____ Date _____

Name The Synonyms

Instructions – Name the synonym pairs in each picture from the word list below. Write your answers under each picture. Color the pictures as you wish.

name - title
far - distant
middle - center

prank - joke
brave - bold
belief - opinion

build - construct
rich - wealthy
find - discover

silly - foolish
remain - stay
vanish - disappear

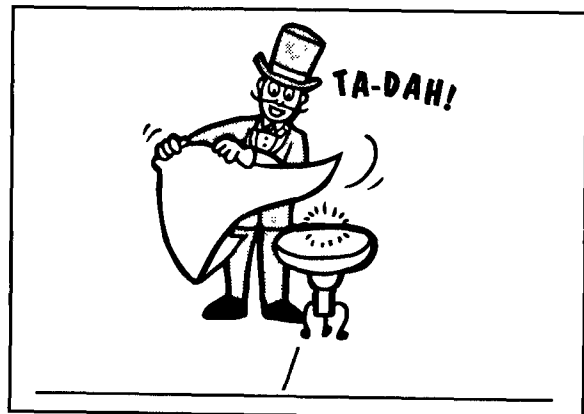
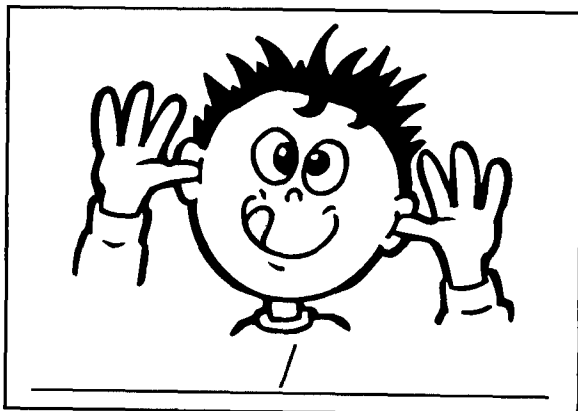
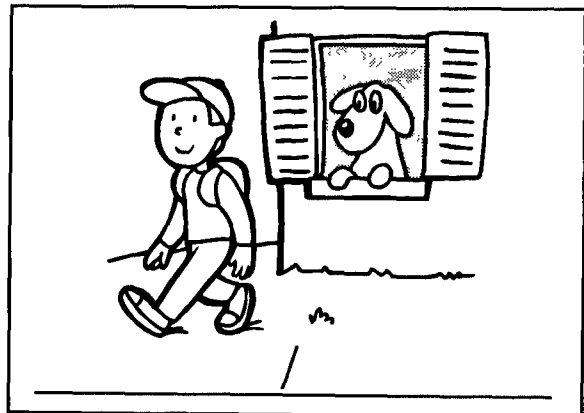
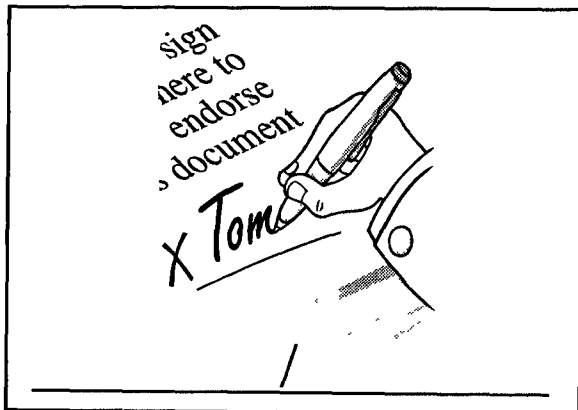
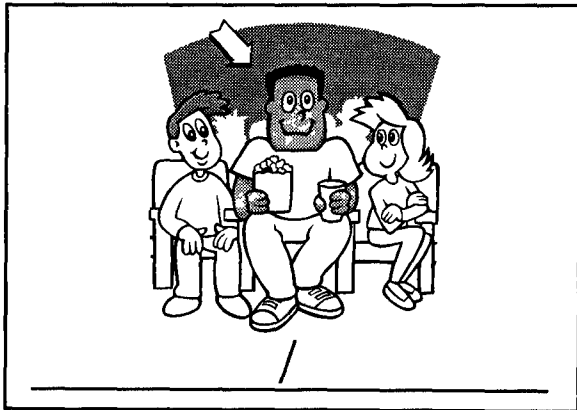

Synonyms are words with one or more similar or same meanings.

Name _____ Date _____

Find the Synonym

Instructions – In the sentence below, one word is underlined. Find a synonym for that underlined word in the list below. Write it in the blank next to the word.

prank - joke
brave - bold
build - construct

name - title
silly - foolish
rich - wealthy

middle - center
remain - stay
belief - opinion

far - distant
vanish - disappear
find - discover

1. I played a trick (_____) on my grandmother when I hid behind the door and pretended I wasn't there.
2. When I went to camp, every piece of clothing had to have your label (_____) on it for identification.
3. For a hobby, my father likes to make (_____) wooden bookcases.
4. Long ago, people thought that the idea of going to the moon one day was absurd (_____).
5. The man received a medal from the president because of his courageous (_____) actions.

Synonym Scramble

Unscramble these words. Write the correct words in the blanks next to the scrambled words. Then, write a sentence for each unscrambled word in the blanks under the words.

1. yewthal- _____
_____.
2. marine- _____
_____.
3. shavin- _____
_____.
4. ercent- _____
_____.
5. vordisec- _____
_____.

Synonyms are words with one or more similar or same meanings.

Name _____ Date _____

Make Your Own Synonym

Instructions – In the boxes below, draw a picture of your favorite synonym pairs. Write the name of each synonym under each picture.

--	--

--	--

Synonyms are words with one or more similar or same meanings.

Name _____ Date _____

Synonym Crossword Puzzle

Instructions – Have fun filling in the crossword puzzle. Each of the answers is a synonym. You may choose your answers from the word list below.

prank - joke
brave - bold
build - construct

name - title
silly - foolish
rich - wealthy

middle - center
remain - stay
belief - opinion

far - distant
vanish - disappear
find - discover

Across

1. Vanish
4. To locate
5. Fearless
7. Not near
9. Well-to-do
10. Ridiculous

Down

2. In the center
3. Make
6. Belief
8. Trick
9. Stay

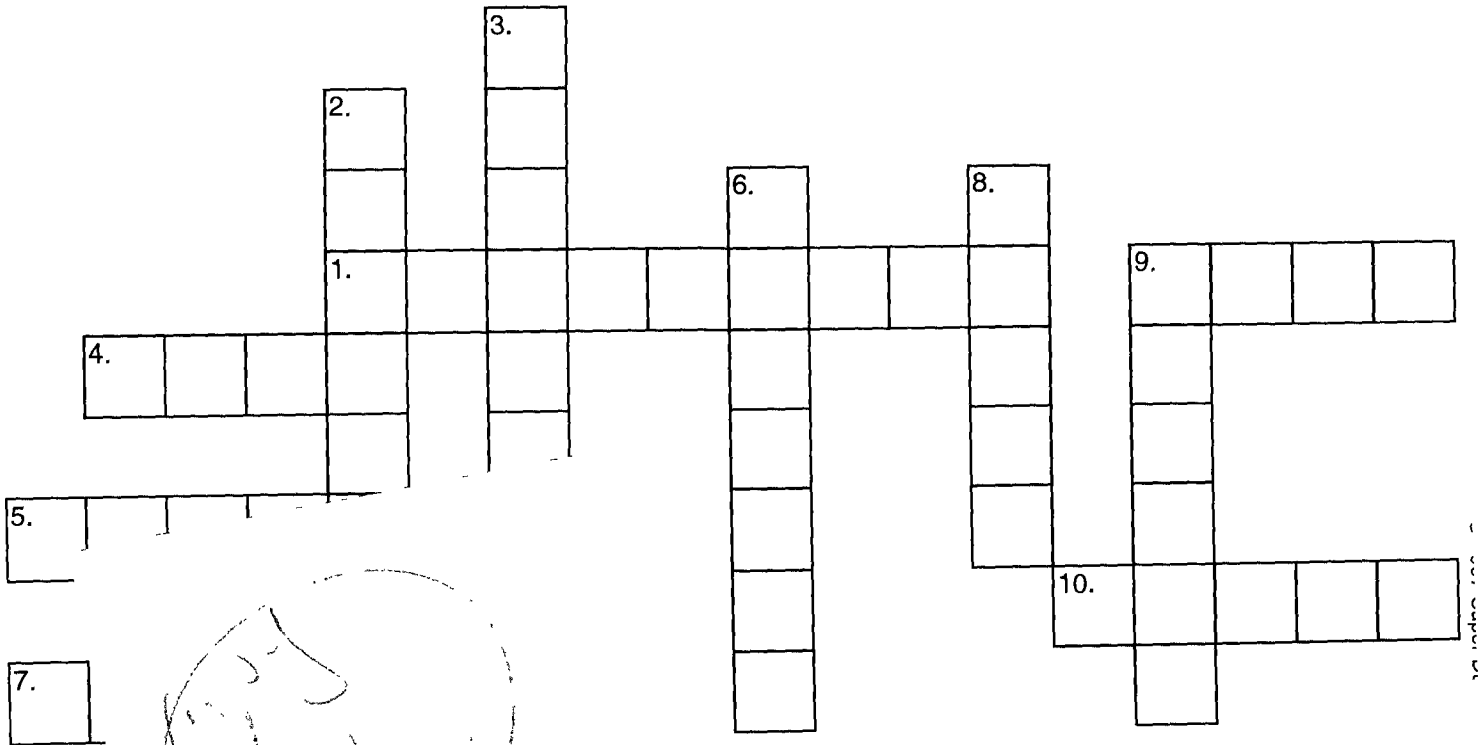

These are words with one or more similar or same meanings.

Name _____ Date _____

Synonyms

Synonyms are words with one or more similar or same meanings.

Instructions – The words in this list show one synonym for each. Yet, you may know more synonyms for each word shown.

1. mean - cruel
2. wet - damp
3. help - assist
4. error - mistake
5. trail - path
6. short - brief

7. first - initial
8. last - final
9. smart - intelligent
10. lost - misplaced
11. join - connect
12. give - donate

Choose the Correct Synonyms

Instructions – Fill in the blanks in each sentence below with the correct pair of synonyms. Choose from the synonym list below.

mean - cruel

error - mistake

first - initial

lost - misplaced

wet - damp

trail - path

last - final

join - connect

help - assist

short - brief

smart - intelligent give - donate

1. The _____ witch in the story put the princess in a dungeon.
2. The _____ question on the test was the hardest to answer.
3. First, the magician had to _____ the two pieces of string.
4. My mom said she is going to _____ my old toys to a charity.
5. I can't believe I _____ my keys again.
6. The _____ time you jump into the water, it seems colder than it really is.
7. I used a _____ washcloth to clean the baby's face.
8. You have to be very _____ if you want to study to be an astronaut.
9. The teacher asked me to _____ her in handing out the test booklets.
10. When I erased the _____ I made, my eraser made a hole in the paper.
11. Today, our lunchtime was cut and we only had a _____ recess.
12. The _____ to the mailbox was very slippery this morning.

Synonyms are words with one or more similar or same meanings.

Name _____ Date _____

Which Synonym Is It?

Instructions – Which one is it? Circle the correct synonym for each sentence.

1. Sometimes, in school, when your name begins with the letter “A”, you can be this in line.
Answer: last , first
2. You can be this if you call other people bad names and hurt their feelings.
Answer: brief, cruel
3. When you volunteer to do some good deeds, you are trying to do this.
Answer: help, connect
4. You walk on this place to get somewhere.
Answer: damp, path
5. When you have just one more chance to write the correct answer, it is this chance.
Answer: final, initial
6. This is the opposite of long.
Answer: last, brief
7. When the weather is hot and very humid, your skin may feel like this.
Answer: smart, damp
8. If you want to get good marks in college, you must be this.
Answer: short, intelligent
9. Sometimes you do this but you didn’t mean to.
Answer: make an error, donate a gift
10. Your book may be this if you can’t find it.
Answer: misplaced, brief
11. When you put two things together to make something work right, you do this to them.
Answer: connect them, assist them
12. When your clothes get old or worn out, you may do this with them.
Answer: donate them to charity, join them to charity

Synonyms are words with one or more similar or same meanings.

Name _____ Date _____

Name The Synonyms

Instructions – Name the synonym pairs in each picture from the word list below. Write your answers under each picture. Color the pictures as you wish.

first - initial
last - final
wet - damp

short - brief
help - assist
join - connect

lost - misplaced
trail - path
error - mistake

mean - cruel
give - donate
smart - intelligent

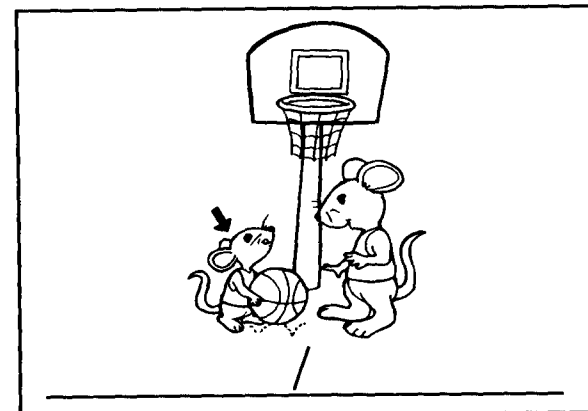
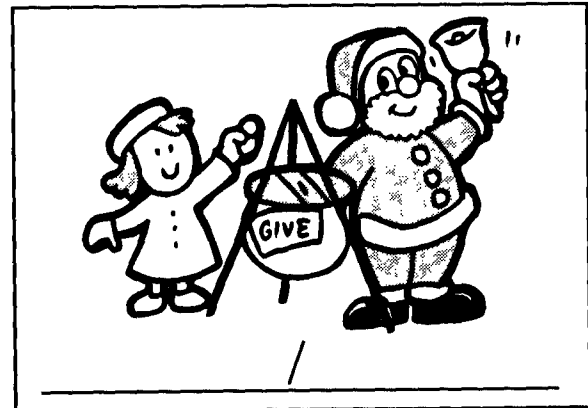
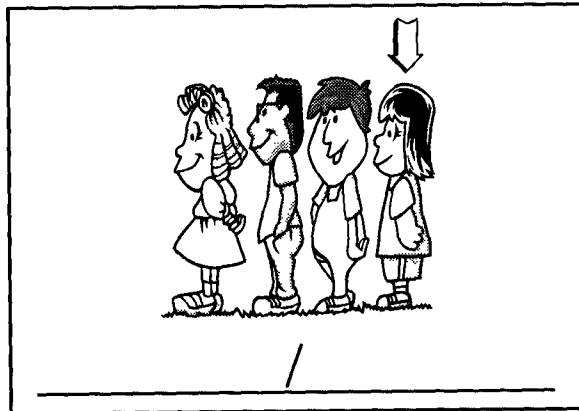
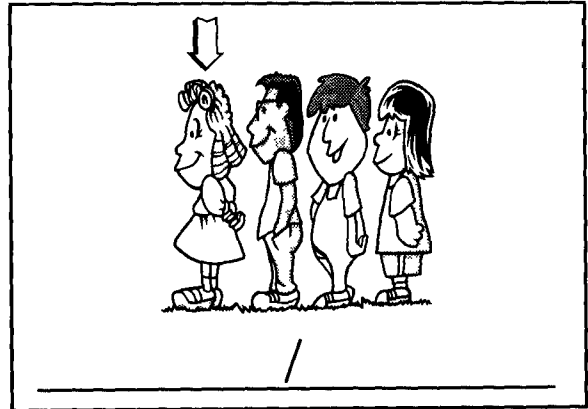
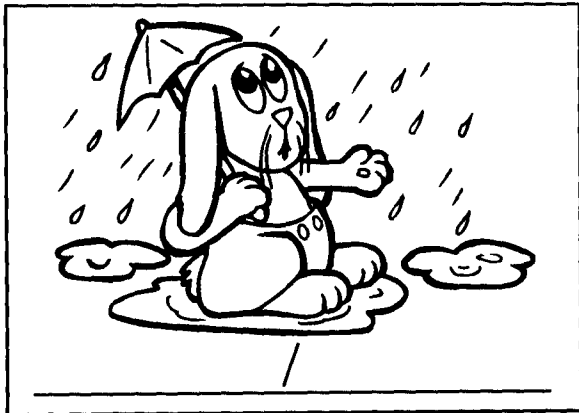

Synonyms are words with one or more similar or same meanings.

Name _____ Date _____

Name The Synonyms

Instructions – Name the synonym pairs in each picture from the word list below. Write your answers under each picture. Color the pictures as you wish.

first - initial
last - final
wet - damp

short - brief
help - assist
join - connect

lost - misplaced
trail - path
error - mistake

mean - cruel
give - donate
smart - intelligent

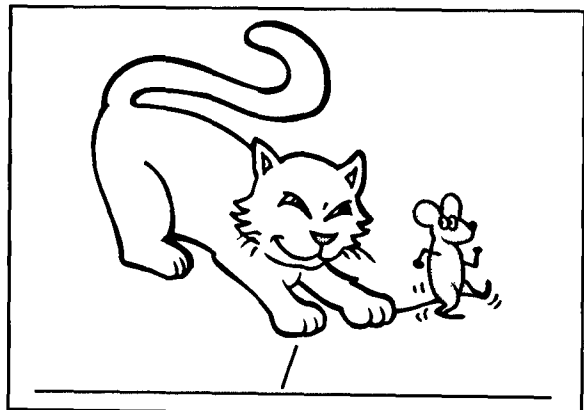
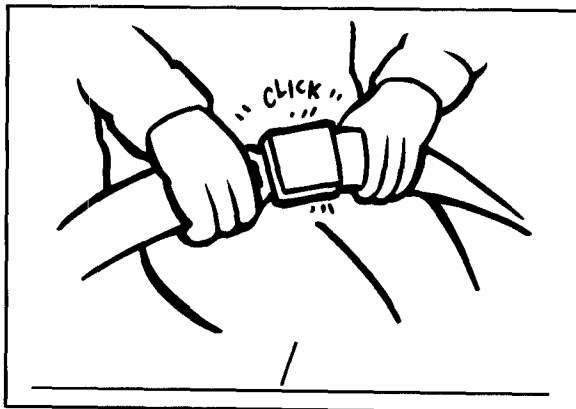
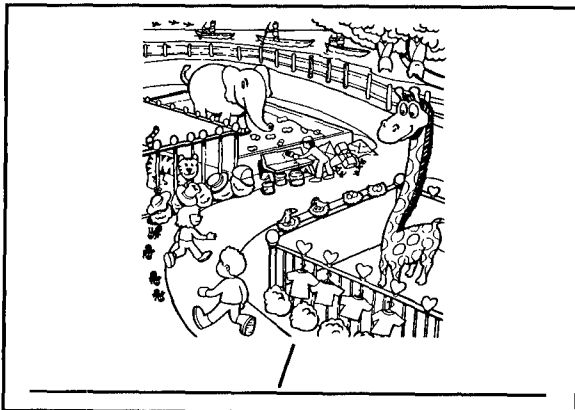
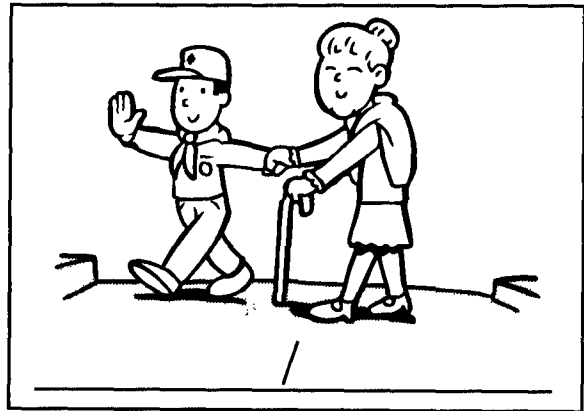
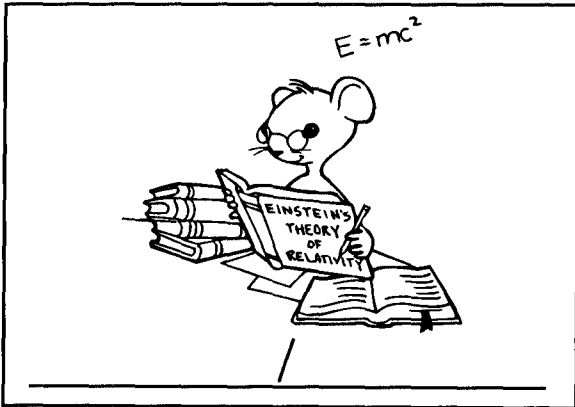

Synonyms are words with one or more similar or same meanings.

Name _____ Date _____

Find the Synonym

Instructions – In the sentence below, one word is underlined. Find a synonym for that underlined word in the list below. Write it in the blank next to the word.

mean - cruel
wet - damp
help - assist

error - mistake
trail - path
short - brief

first - initial
last - final
smart - intelligent

lost - misplaced
join - connect
give - donate

1. My father said you had to be very bright (_____) if you wanted to get into an Ivy League college.
2. The towels were still moist (_____) when I took them out of the dryer.
3. The book was so boring, I couldn't read it all the way to the end (_____) chapter.
4. My friend said she would support (_____) me if I wanted to run for class president.
5. For a change, the stepmother in the fairytale was kind and not nasty (_____).

Synonym Scramble

Unscramble these words. Write the correct words in the blanks next to the scrambled words. Then, write a sentence for each unscrambled word in the blanks under the words.

1. sistas – _____

2. cennoct– _____

3. larit– _____

4. splamdice– _____

5. lucer– _____

Synonyms are words with one or more similar or same meanings.

Name _____ Date _____

Make Your Own Synonym

Instructions – In the boxes below, draw a picture of your favorite synonym pairs. Write the name of each synonym under each picture.

--	--

--	--

Synonyms are words with one or more similar or same meanings.

Name _____ Date _____

Synonym Crossword Puzzle

Instructions – Have fun filling in the crossword puzzle. Each of the answers is a synonym.
 You may choose your answers from the word list below.

mean - cruel
 wet - damp
 help - assist

error - mistake
 trail - path
 short - brief

first - initial
 last - final
 smart - intelligent

lost - misplaced
 join - connect
 give - donate

Across

1. Mislaid
3. An incorrect answer
5. At the end
6. Covered with water
8. To fasten together or link
10. To give aid or support

Down

2. Ability to learn quickly
4. Hurting someone purposely and enjoying it
7. At the beginning
9. Path or track
11. Short in length
12. Contribute a gift to a fund or cause

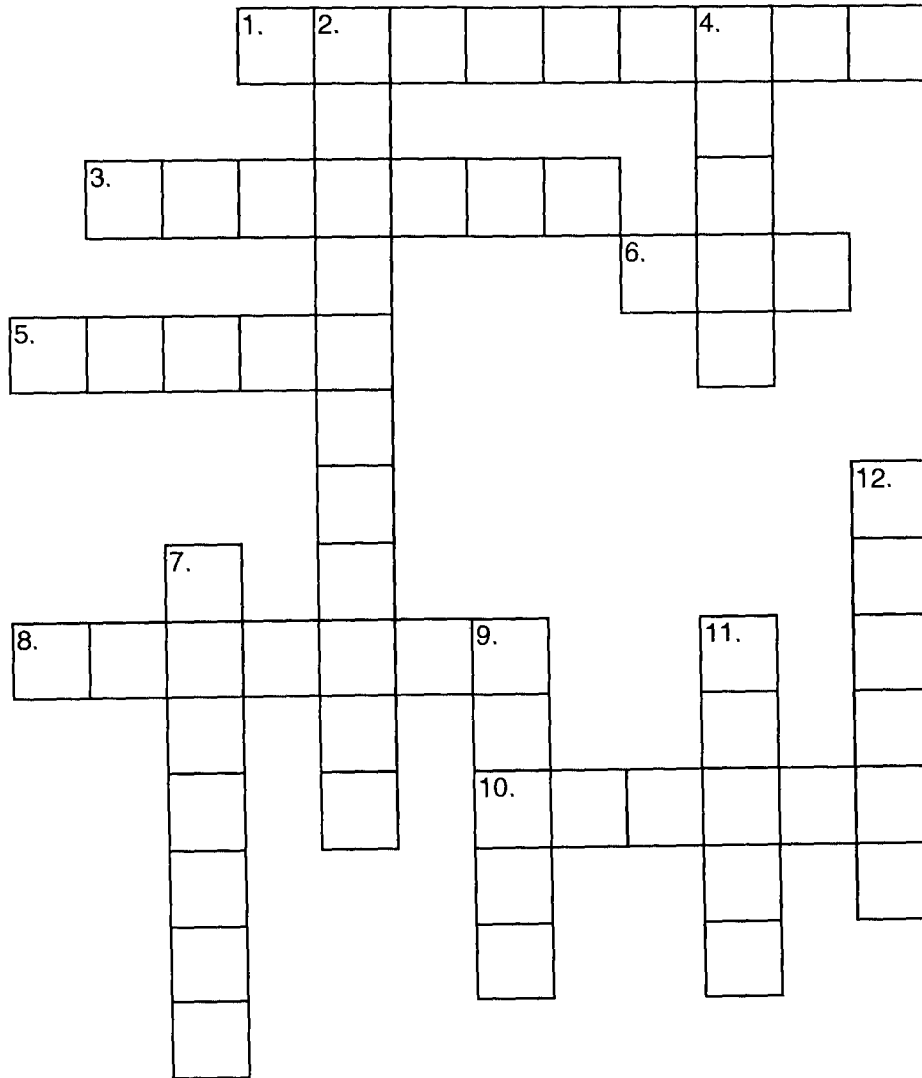

Synonyms are words with one or more similar or same meanings.

Name _____ Date _____

Synonyms

Synonyms are words with one or more similar or same meanings.

Instructions – The words in this list show one synonym for each. Yet, you may know more synonyms for each word shown.

- | | |
|-----------------------|-------------------------|
| 1. portion - piece | 7. teacher - instructor |
| 2. funny - amusing | 8. buy - purchase |
| 3. empty - vacant | 9. wages - salary |
| 4. stingy - miserly | 10. guest - visitor |
| 5. answer - response | 11. false - wrong |
| 6. fantasy - daydream | 12. messy - untidy |

Choose the Correct Synonyms

Instructions – Fill in the blanks in each sentence below with the correct pair of synonyms. Choose from the synonym list below.

portion - piece	stingy - miserly	teacher - instructor	guest - visitor
funny - amusing	answer - response	buy - purchase	false - wrong
empty - vacant	fantasy - daydream	wages - salary	messy - untidy

1. The motel sign said there was only one _____ room left.
2. I wrote a letter to the president and I'm still waiting patiently for a _____.
3. Even though the lady was rich, she was _____ with her money.
4. My favorite _____ is to become a famous author and be recognized wherever I go.
5. My father said we will need to _____ a new car soon, since the one we have now is falling apart.
6. My teacher is always scolding me for having such a _____ desk.
7. I was so happy to have only one answer _____ on the test.
8. I gave my last _____ of Halloween candy to my baby sister.
9. The entertainer was so _____, we couldn't stop laughing.
10. My mother's golf _____ said she was the best student he ever had.
11. I wondered when I would ever be able to work and earn _____ .
12. My friend Pat invited me to be a _____ at her country home this summer.

Synonyms are words with one or more similar or same meanings.

Name _____ Date _____

Which Synonym Is It?

Instructions – Which one is it? Circle the correct synonym for each sentence.

1. When nothing is in the room, you can say that the room is this.

Answer: untidy, vacant

2. This word is the opposite of generous.

Answer: amusing, stingy

3. When something is not true, it is this.

Answer: false, empty

4. When you want a small bit of something, you want this.

Answer: wages, a piece

5. You may laugh when something is this.

Answer: wrong, funny

6. You usually get this when you send someone a letter.

Answer: a fantasy, a response

7. Someone who helps you to learn something new is this person.

Answer: an instructor, a visitor

8. When you imagine something that is not really true, it is this.

Answer: an answer, a daydream

9. You pay money when you do this for something you want.

Answer: purchase, answer

10. When you work for someone you get this.

Answer: a salary, a response

11. When you stay for a time in someone's house, you are this.

Answer: a visitor, a teacher

12. When your bedroom has clothes and toys and books all over the place and not in the proper place, your room looks like this.

Answer: wrong, untidy

Synonyms are words with one or more similar or same meanings.

Name _____ Date _____

Name The Synonyms

Instructions – Name the synonym pairs in each picture from the word list below. Write your answers under each picture. Color the pictures as you wish.

fantasy - daydream

empty - vacant

answer - response

portion - piece

buy - purchase

messy - untidy

wages - salary

teacher - instructor

funny - amusing

stingy - miserly

false - wrong

guest - visitor

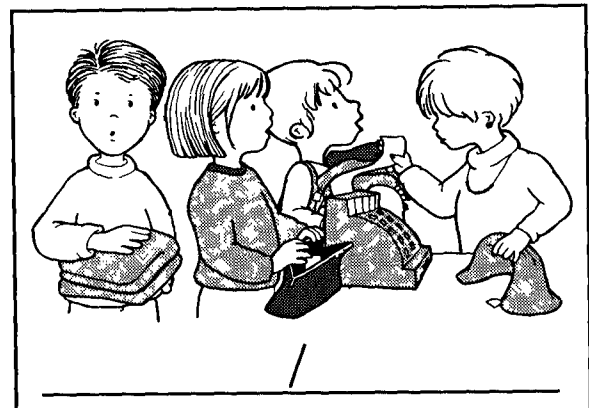
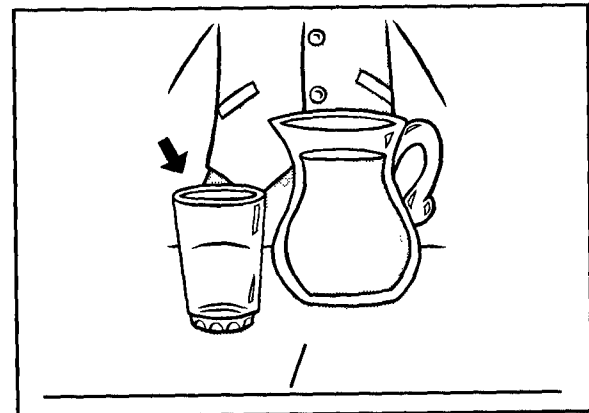
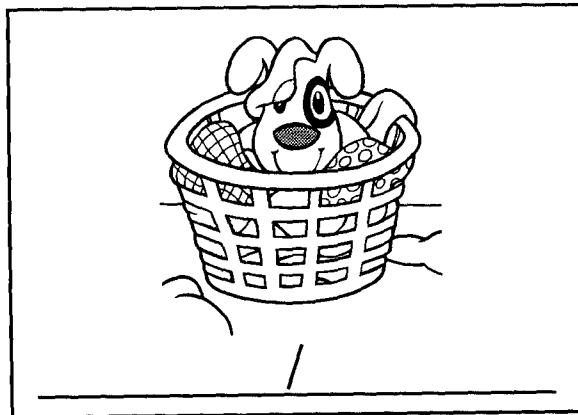
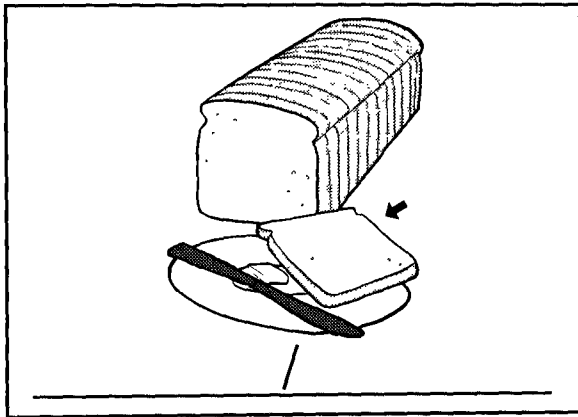

Synonyms are words with one or more similar or same meanings.

Name _____ Date _____

Name The Synonyms

Instructions – Name the synonym pairs in each picture from the word list below. Write your answers under each picture. Color the pictures as you wish.

fantasy - daydream
empty - vacant
answer - response

portion - piece
buy - purchase
messy - untidy

wages - salary
teacher - instructor
funny - amusing

stingy - miserly
false - wrong
guest - visitor

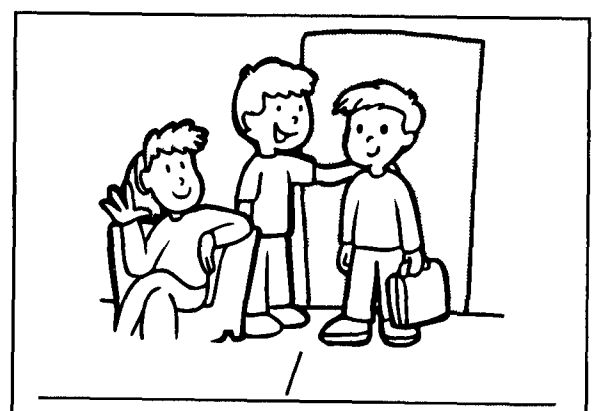
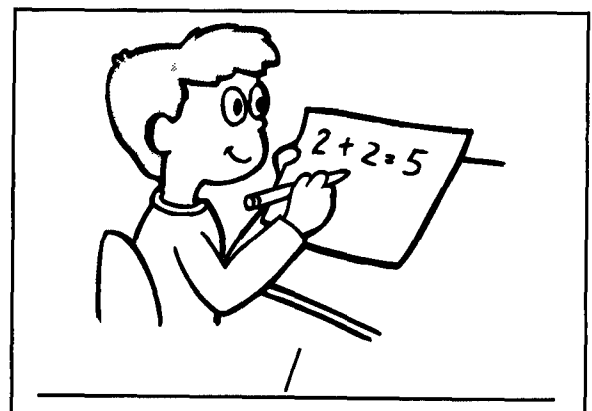
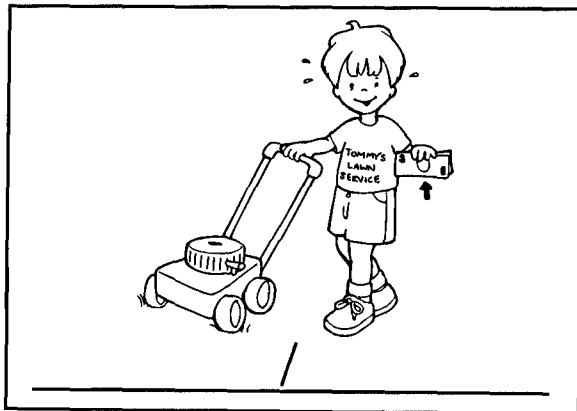
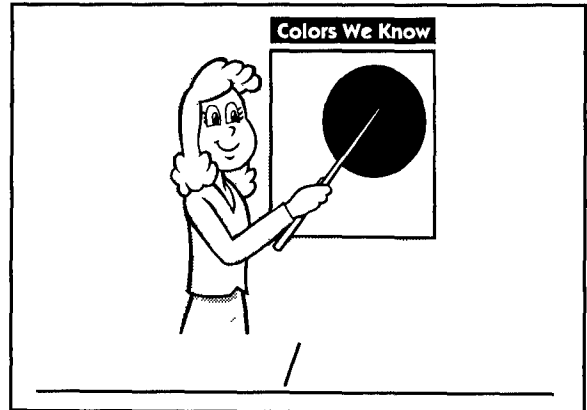
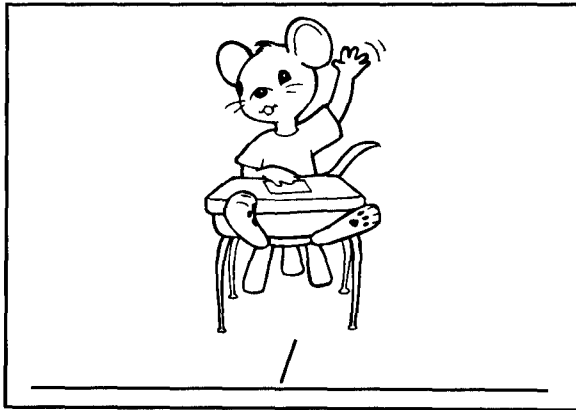

Synonyms are words with one or more similar or same meanings.

Name _____ Date _____

Find the Synonym

Instructions – In the sentence below, one word is underlined. Find a synonym for that underlined word in the list below. Write it in the blank next to the word.

portion - piece
 funny - amusing
 empty - vacant

stingy - miserly
 answer - response
 fantasy - daydream

teacher - instructor
 buy - purchase
 wages - salary

guest - visitor
 false - wrong
 messy - untidy

1. I'm only going to have a small fraction (_____) of the lasagna that my mother cooked for the family.
2. The room was bare (_____) and had no pictures or furniture.
3. It has been one month and I still haven't received a reply (_____) to the letter I sent my friend in Mexico.
4. My grandfather was known in the family for telling very humorous (_____) stories of when he was a boy.
5. Mr. Kelsey was known as the most selfish (_____) man on our block.

Synonym Scramble

Unscramble these words. Write the correct words in the blanks next to the scrambled words. Then, write a sentence for each unscrambled word in the blanks under the words.

1. pitnoor– _____

2. maddyare– _____

3. stuge– _____

4. slafe– _____

5. sharecup– _____

Synonyms are words with one or more similar or same meanings.

Name _____ Date _____

Make Your Own Synonym

Instructions – In the boxes below, draw a picture of your favorite synonym pairs. Write the name of each synonym under each picture.

--	--

--	--

Synonyms are words with one or more similar or same meanings.

Name _____ Date _____

Synonym Crossword Puzzle

Instructions – Have fun filling in the crossword puzzle. Each of the answers is a synonym.
 You may choose your answers from the word list below.

portion - piece
 funny - amusing
 empty - vacant

stingy - miserly
 answer - response
 fantasy - daydream

teacher - instructor
 buy - purchase
 wages - salary

guest - visitor
 false - wrong
 messy - untidy

Across

1. Someone who stays at your house for a while
3. A person who teaches you
7. Comical
8. Containing nothing
11. Payment of services to a workman

Down

2. Not neat, sloppy
4. Not wanting to spend money
5. To pay money for an item
6. Not correct
7. Something you just imagine or make-believe
9. A reply to a question
10. A fraction

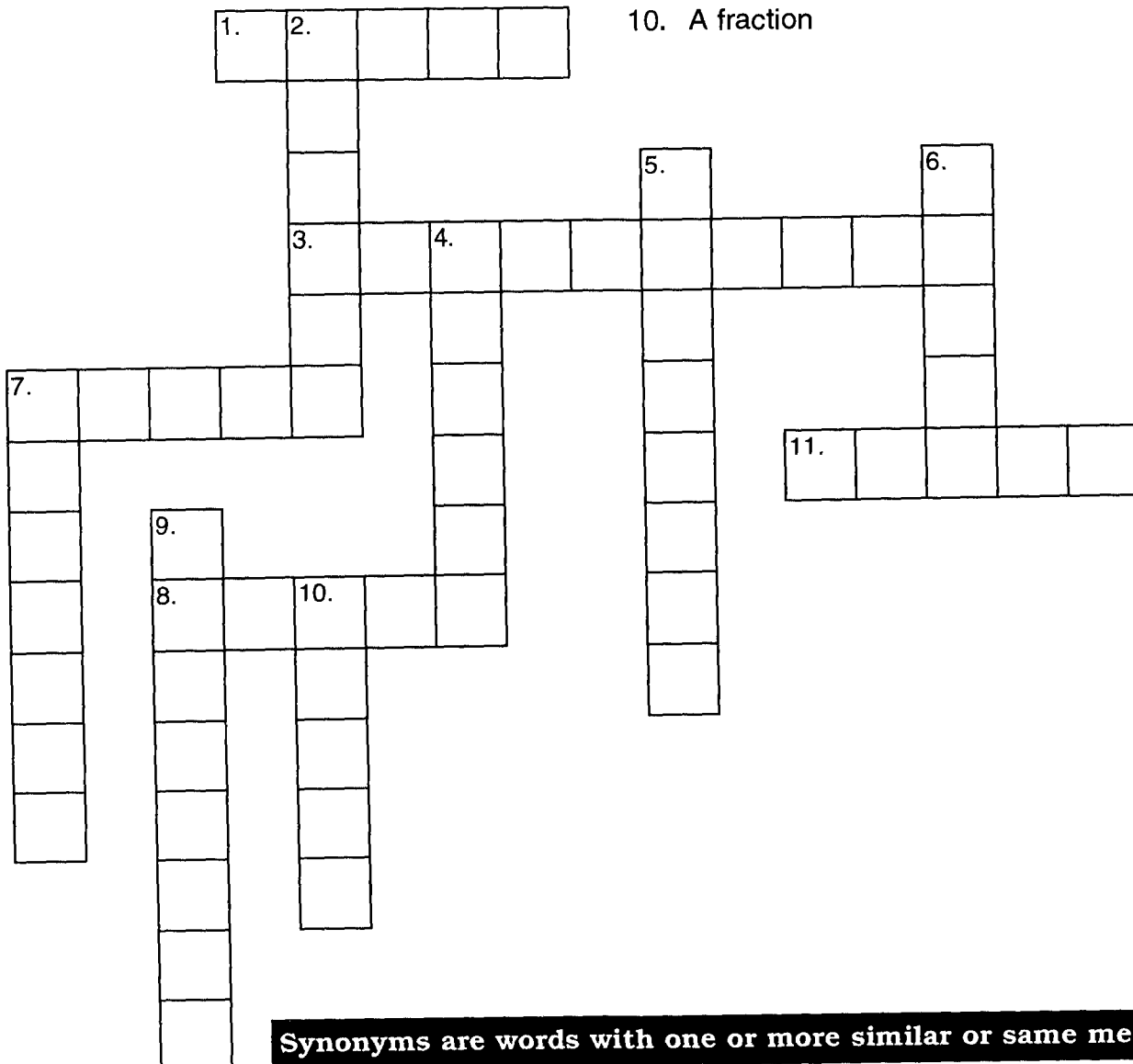

Synonyms are words with one or more similar or same meanings.

Name _____ Date _____

Synonyms

Synonyms are words with one or more similar or same meanings.

Instructions – The words in this list show one synonym for each. Yet, you may know more synonyms for each word shown.

1. new - unused

2. scared - frightened

3. strange - odd

4. real - genuine

5. imitate - copy

6. often - frequently

7. careful - cautious

8. silent - quiet

9. rarely - seldom

10. busy - active

11. agree - consent

12. perhaps - maybe

Choose the Correct Synonyms

Instructions – Fill in the blanks in each sentence below with the correct pair of synonyms. Choose from the synonym list below.

new - unused	real - genuine	careful - cautious	busy - active
scared - frightened	imitate - copy	silent - quiet	agree - consent
strange - odd	often - frequently	rarely - seldom	perhaps - maybe

- The sparkling stone looked _____, but it was just a fake.
- My dad _____ tells me to stop slouching and sit up straight.
- I'm very _____ when I eat an ice cream cone; I don't want to get the ice cream on my white shirt.
- My friend said I could borrow her book, but I wanted to have my own _____ one.
- Sometimes I try to _____ my mother's handwriting, but it isn't as easy as it looks.
- My father said he would _____ to let me go to the concert if I did all my homework.
- After I got a calculator, I _____ added or subtracted numbers without it.
- When my sister got her hair cut very short, she looked so _____ to me at first.
- The audience was very _____ as soon as the first act of the play began.
- " _____ you should call your new friend to go with you to the library," my mother said.
- My aunt lives a very _____ life, even though she is a senior citizen.
- My dog always gets _____ and runs under the bed when there is a thunderstorm.

Synonyms are words with one or more similar or same meanings.

Name _____ Date _____

Which Synonym Is It?

Instructions – Which one is it? Circle the correct synonym for each sentence.

1. The pictures painted by famous artists that hang in museums are this.

Answer: unused, genuine

2. The opposite of often is this.

Answer: busy, seldom

3. Something that looks peculiar or out of the ordinary is this.

Answer: real, odd

4. When you do something over and over again and again, this is when you do this.

Answer: often, rarely

5. When you want to be exactly like someone else, you want to do this.

Answer: agree, imitate

6. Doing many different things in a day is called this.

Answer: cautious, busy

7. When you are afraid you are this.

Answer: silent, frightened

8. When you are not sure of something, you might say this.

Answer: quiet, perhaps

9. If you want to be safe you should be this.

Answer: cautious, active

10. When you say “yes” you do this.

Answer: maybe, agree

11. When there is no noise or talking, it is this.

Answer: busy, quiet

12. When you buy clothing it is usually this.

Answer: unused, real

Synonyms are words with one or more similar or same meanings.

Name _____ Date _____

Name The Synonyms

Instructions – Name the synonym pairs in each picture from the word list below. Write your answers under each picture. Color the pictures as you wish.

frightened - scared

busy - active

agree - consent

often - frequently

strange - odd

silent - quiet

new - unused

perhaps - maybe

imitation - copy

real - genuine

careful - cautious

rarely - seldom

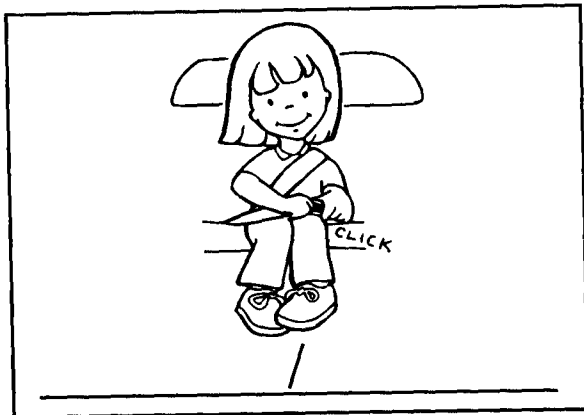
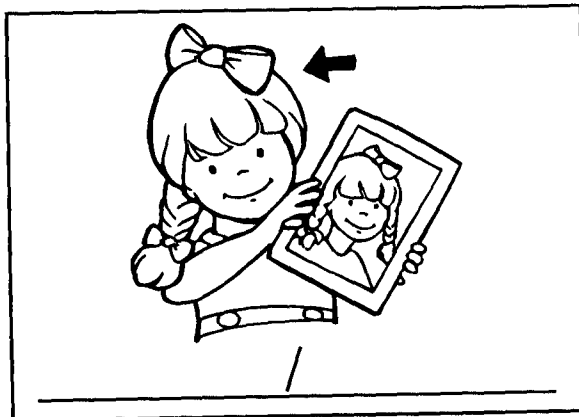
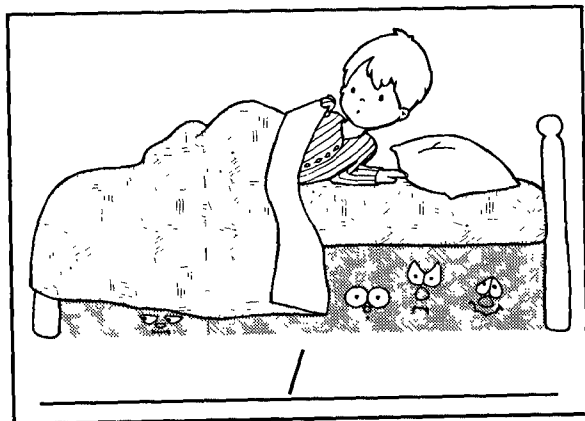
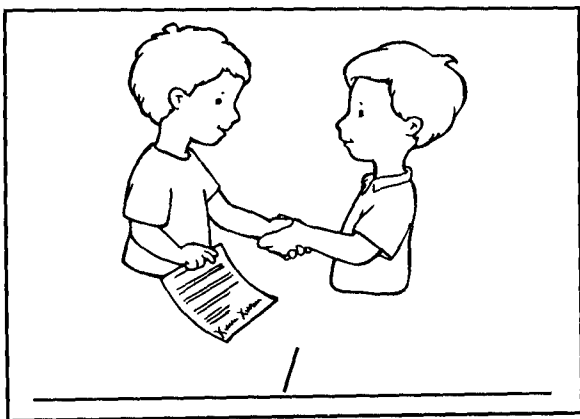

Synonyms are words with one or more similar or same meanings.

Name _____ Date _____

Name The Synonyms

Instructions – Name the synonym pairs in each picture from the word list below. Write your answers under each picture. Color the pictures as you wish.

frightened - scared
 strange - odd
 imitation - copy

busy - active
 silent - quiet
 real - genuine

agree - consent
 new - unused
 careful - cautious

often - frequently
 perhaps - maybe
 rarely - seldom

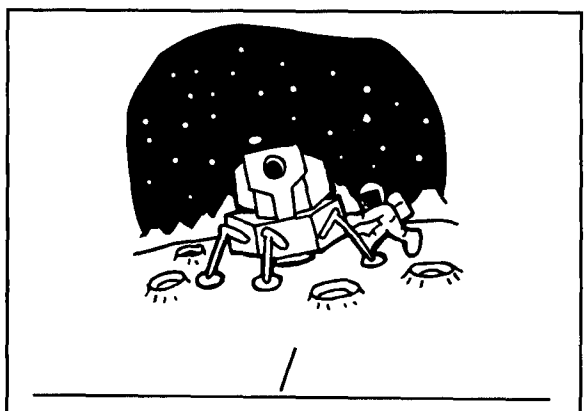
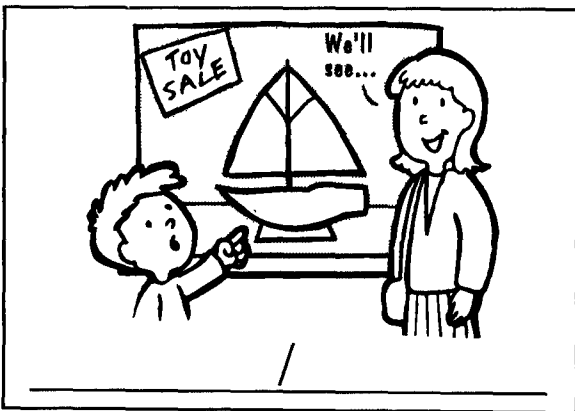
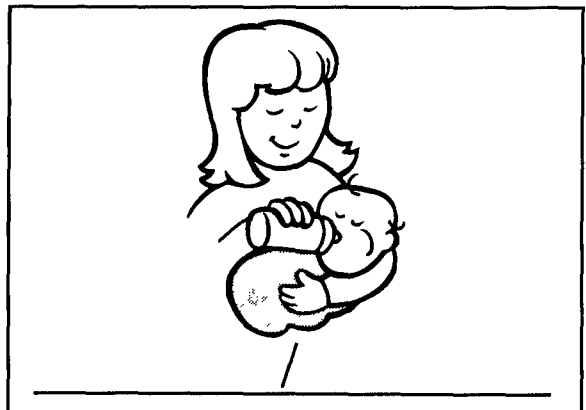
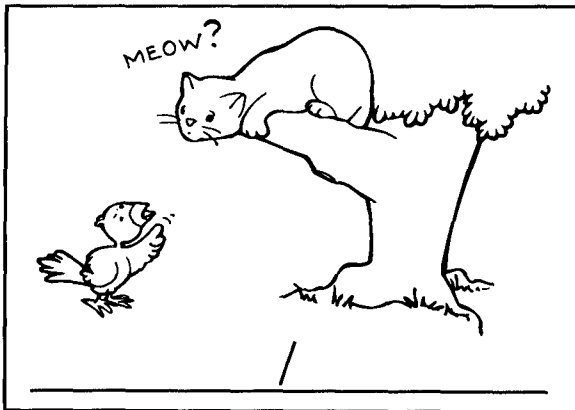
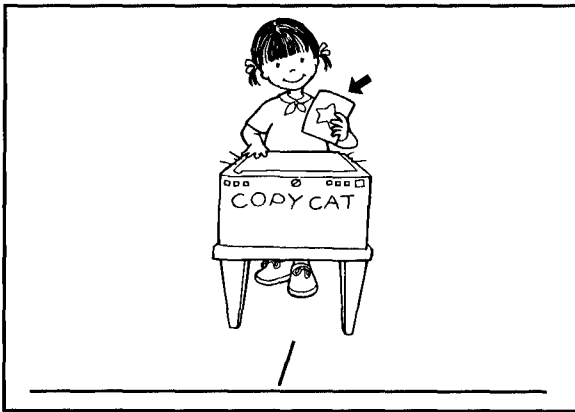

© 1997 Super Duper® Publications 1-800-277-8737

Synonyms are words with one or more similar or same meanings.

Name _____ Date _____

Find the Synonym

Instructions – In the sentence below, one word is underlined. Find a synonym for that underlined word in the list below. Write it in the blank next to the word.

new - unused

real - genuine

careful - cautious

busy - active

scared - frightened

imitate - copy

silent - quiet

agree - consent

strange - odd

often - frequently

rarely - seldom

perhaps - maybe

1. The expert said the painting was authentic (_____) ; it was painted by Rembrandt.
2. My friend's mother gave me a fresh (_____) washcloth to use for the week-end.
3. My classmate Jimmy always gets in trouble when he mimics (_____) the teacher.
4. "Don't be afraid (_____) to try new things," my parents always told me.
5. The old dog was very cute, but it had a peculiar (_____) odor.

Synonym Scramble

Unscramble these words. Write the correct words in the blanks next to the scrambled words. Then, write a sentence for each unscrambled word in the blanks under the words.

1. ambey – _____

2. listen – _____

3. vitace – _____

4. grantes – _____

5. enguine– _____

Synonyms are words with one or more similar or same meanings.

Name _____ Date _____

Make Your Own Synonym

Instructions – In the boxes below, draw a picture of your favorite synonym pairs. Write the name of each synonym under each picture.

--	--

--	--

Synonyms are words with one or more similar or same meanings.

Name _____ Date _____

Synonym Crossword Puzzle

Instructions — Have fun filling in the crossword puzzle. Each of the answers is a synonym.
You may choose your answers from the word list below.

new - unused
scared - frightened
strange - odd

real - genuine
imitate - copy
often - frequently

careful - cautious
silent - quiet
rarely - seldom

busy - active
agree - consent
perhaps - maybe

Across

Down

1. Trying not to make a mistake
3. To have the same opinion as someone else
5. To be fearful
6. Happening just once in a while
8. Not yet used
10. Occupied
11. Making no noise

2. Weird
4. To try to act or look like someone else
5. To happen many times
7. Possibly
9. Not artificial

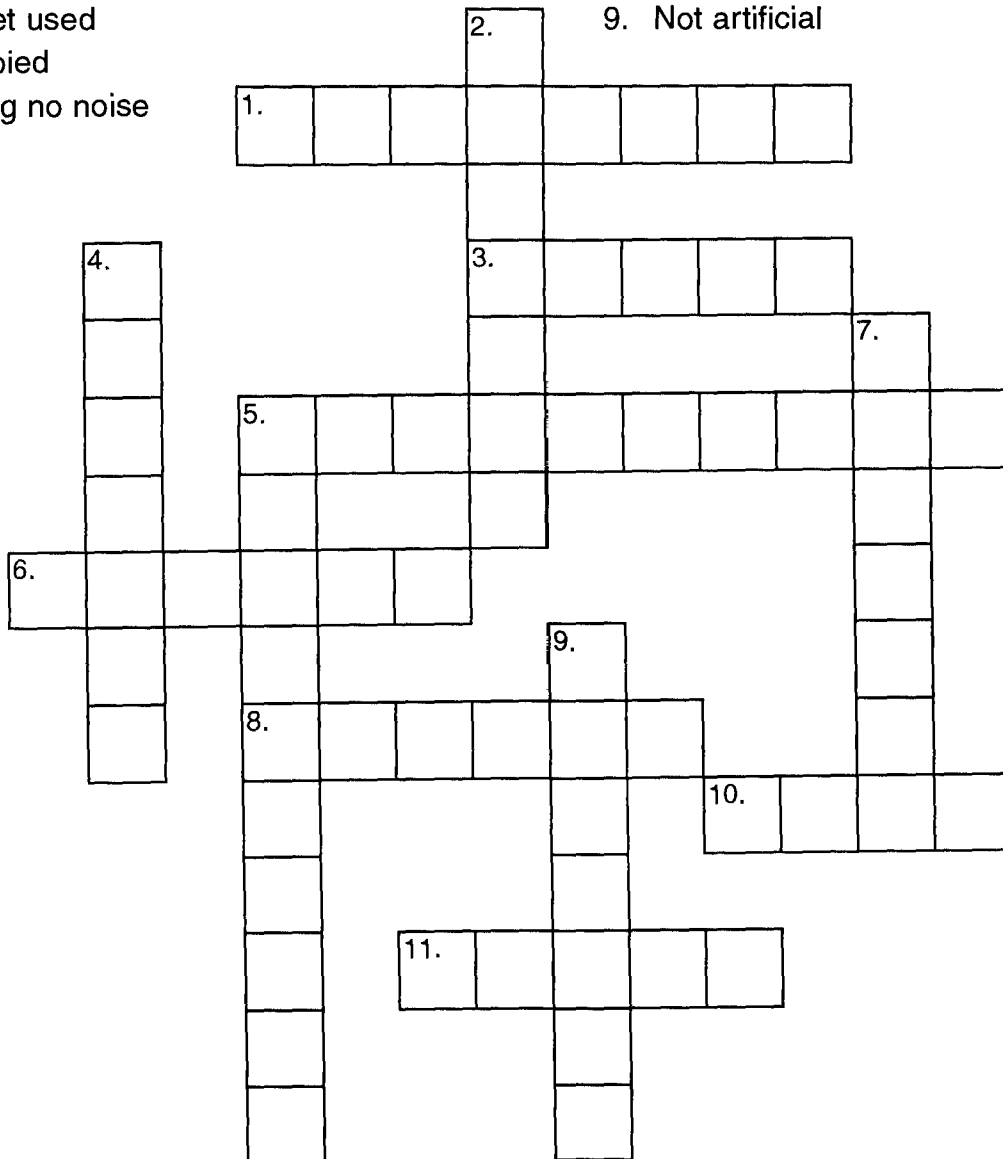

Synonyms are words with one or more similar or same meanings.

Name _____ Date _____

Homophones

Homophones are two or more words that sound alike but are spelled differently and have different meanings.

Instructions – Here is a list of homophones for this lesson. Read them out loud so you can hear that they sound alike.

- | | |
|------------------------|--------------------|
| 1. aunt - ant | 7. ail - ale |
| 2. beet - beat | 8. bear - bare |
| 3. bee - be | 9. eye - I |
| 4. berry - bury | 10. flower - flour |
| 5. cent - sent - scent | 11. urn - earn |
| 6. cord - chord | 12. ewe - you |

Choose the Correct Homophone

Instructions – Read the sentences below and fill in the blanks with the correct homophones. You may look in the dictionary after you complete this exercise to see if you chose the right homophone. Correct any mistakes by crossing out or erasing your first answer and writing in the correct homophone.

1. I have an _____ by the name of Sue.
(ant, aunt)
2. There was a big _____ crawling on the picnic table.
(ant, aunt)
3. The song has a strong _____ and you can dance to it.
(beet, beat)
4. My baby brother spilled _____ juice on himself.
(beat, beet)
5. The _____ buzzed around the honey.
(be, bee)
6. I can't _____ at your house until 7:00 pm.
(be, bee)
7. I wanted to _____ my dead parakeet in the backyard.
(bury, berry)
8. The blue bird flew away with a _____ in its mouth.
(berry, bury)
9. The flowery _____ of her perfume remained in the room after she left.
(sent, scent, cent)
10. I _____ the package to my aunt in Rhode Island.
(cent, scent, sent)
11. The gum ball only cost one _____.
(scent, cent, sent)
12. The telephone _____ was badly tangled.
(chord, cord)

Homophones are two or more words that sound alike but are spelled differently and have different meanings.

Name _____ Date _____

Choose the Correct Homophone

Continued

13. The pianist began his piece with a loud _____.
(cord, chord)
14. The knights sat around the wooden table and drank _____.
(ale, ail)
15. When our old cat began to _____, we had to put him to sleep.
(ail, ale)
16. We took a picture of the grizzly _____ through the closed window.
(bear, bare)
17. My baby sister likes to walk around outside in her _____ feet.
(bare, bear)
18. When _____ go to the beach, I always bring lots of suntan lotion.
(eye, I)
19. The wind blew a cinder into my _____.
(eye, I)
20. The cake had to be made with three cups of _____.
(flower, flour)
21. My favorite kind of _____ is the tulip.
(flour, flower)
22. I sometimes _____ money babysitting.
(earn, urn)
23. There was a big, silver _____ on the mantelpiece.
(earn, urn)
24. On the farm we saw a large _____ grazing in the field.
(ewe, you)
25. Why don't _____ call me when you get home?
(you, ewe)

Homophones are two or more words that sound alike but are spelled differently and have different meanings.

Name _____ Date _____

Name The Homophones

Instructions – Look at each set of pictures below. Choose the correct homophones for each set from the word list, and write them in the spaces provided.

beet - beat
bear - bare

eye - I
flour - flower

berry - bury
urn - earn

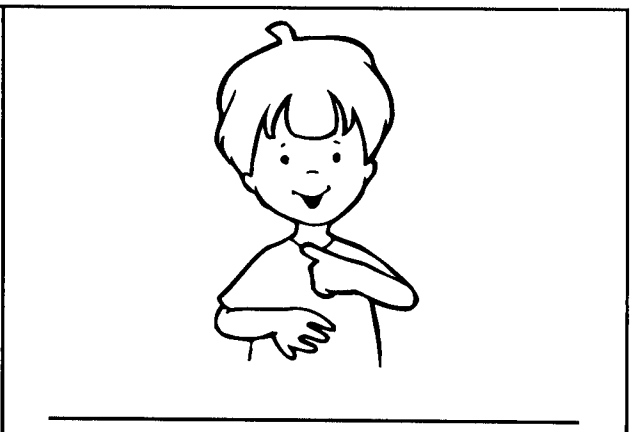
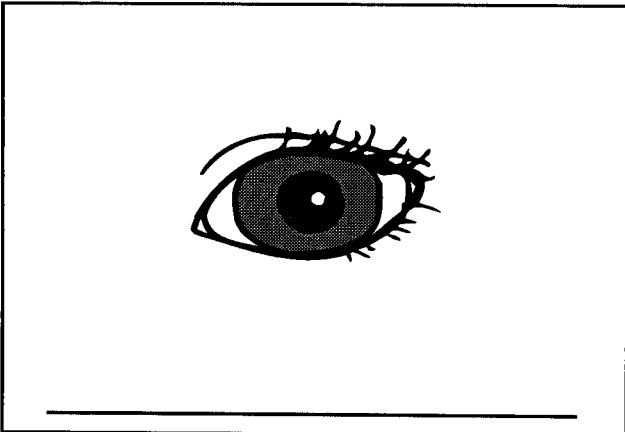
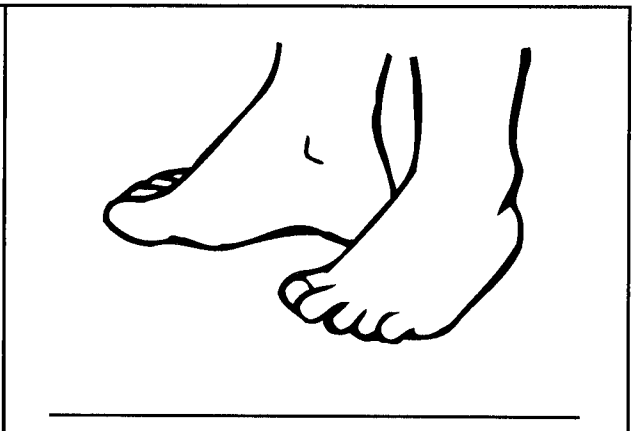
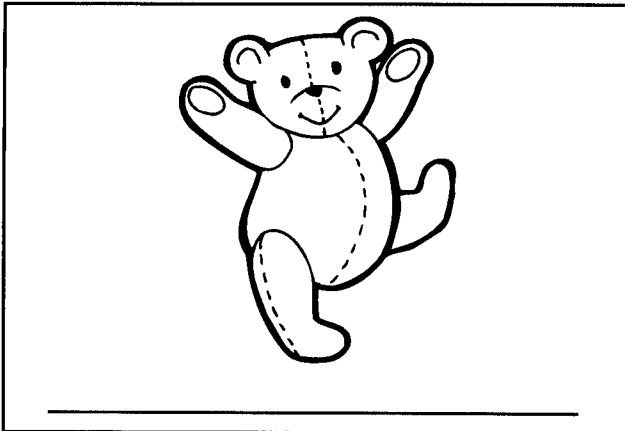
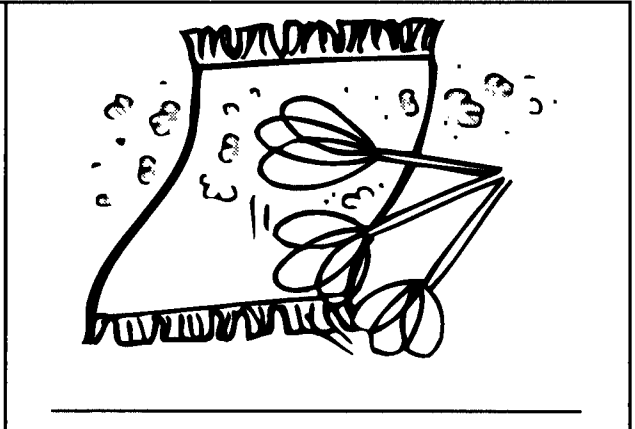
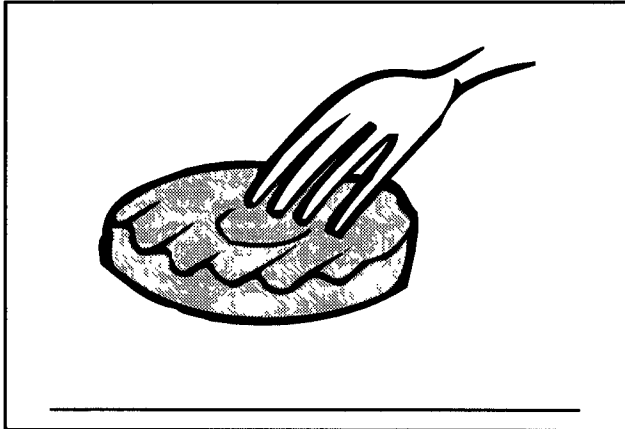

Homophones are two or more words that sound alike but are spelled differently and have different meanings.

Name _____ Date _____

Name The Homophones

Instructions – Look at each set of pictures below. Choose the correct homophones for each set from the word list, and write it in the spaces provided.

beet - beat
bear - bare

eye - I
flour - flower

berry - bury
urn - earn

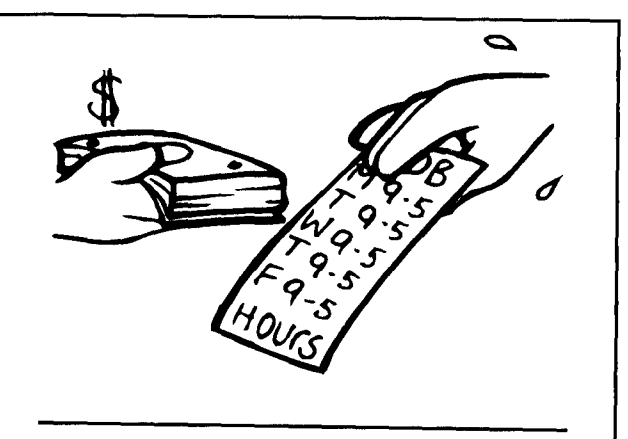
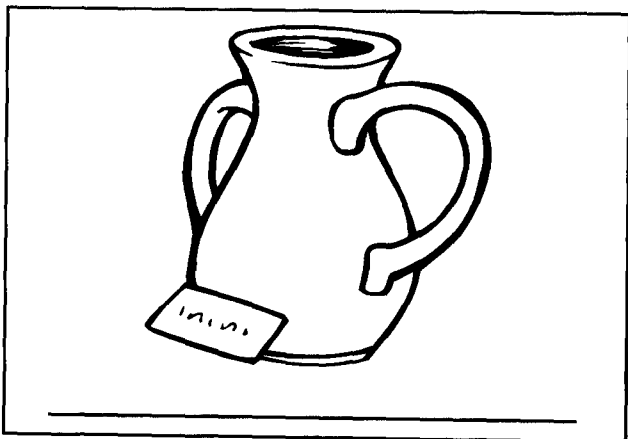
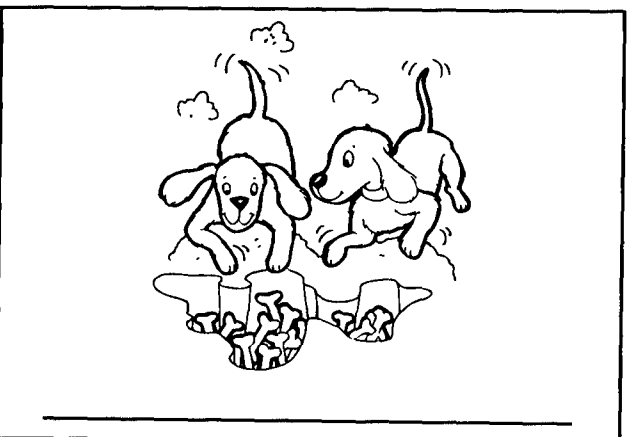
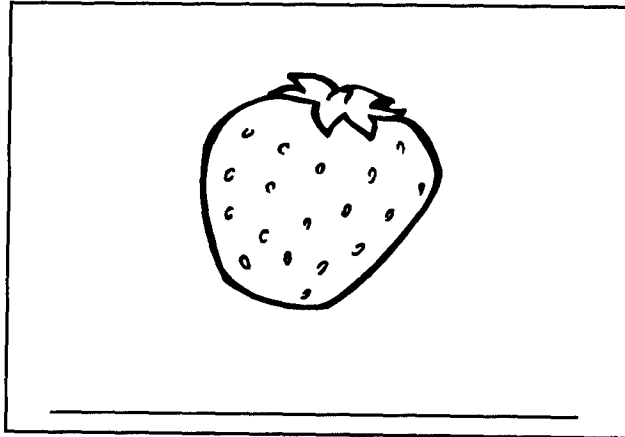
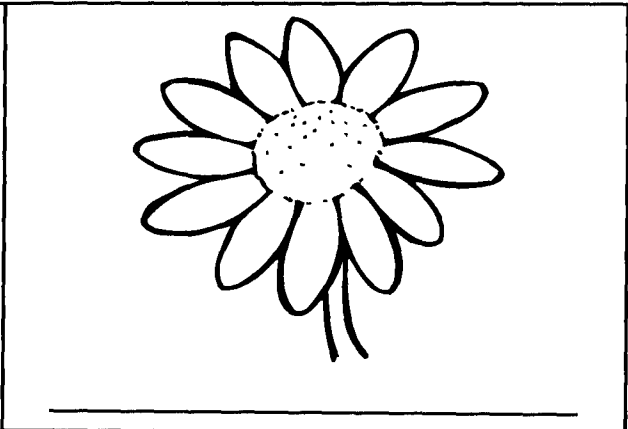
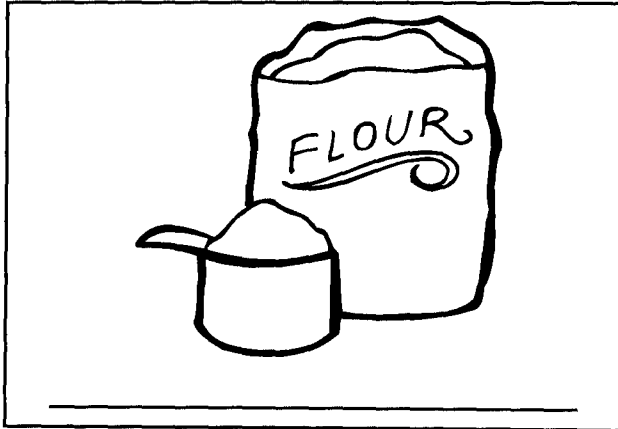

Homophones are two or more words that sound alike but are spelled differently and have different meanings.

Name _____ Date _____

Which Homophone Is It?

Instructions – Which one is it? Circle the correct homophone for each sentence.

1. A tree has no leaves in the winter. Its branches are this.

Answer: bear, bare

2. You do this to a drum to make music or to a rug to get the dust out of it.

Answer: beet it, beat it

3. A squirrel may do this with a nut.

Answer: berry it, bury it

4. A special police dog follows this with his nose in order to find a criminal who has run away.

Answer: a sent, a scent, a cent

5. This is a string or a light rope.

Answer: a chord, a cord

6. This grows in your garden and can be many different colors.

Answer: a flower, a flour

7. Your mother or father may do this every day at a job.

Answer: earn money, urn money

8. We call ourselves “I” when we speak of ourselves. When we speak to another person about themselves, we say this...

Answer: ewe, you

9. This is a female relative of yours. She is your mother’s or father’s sister.

Answer: ant, aunt

10. This is the main ingredient of cakes and cookies.

Answer: flower, flour

11. An insect that has four wings and a stinger is called this.

Answer: a be, a bee

12. To feel ill or sick is to do this...

Answer: to ail, to ale

Homophones are two or more words that sound alike but are spelled differently and have different meanings.

Name _____ Date _____

Correction Time

Instructions – Some of the homophones in the sentences below are correct, and some are wrong. If the homophone is correct, leave the sentence alone. If the homophone is wrong, cross it out and write the correct word above the wrong one.

1. What do **eye** have to do to win the contest?
2. A **ewe** is a female sheep.
3. A **beat** is a red vegetable that grows underground.
4. My dog likes to **berry** his bones in the backyard.
5. Will you **bee** coming to my house for dinner tonight?
6. I **cent** you a long letter last week.
7. My sister played a loud **chord** on the piano.
8. My father drank a mug of **ale** at the county fair.
9. There was a big wasp flying around the **flour** in the vase.
10. The coffee was poured from a large **earn**.
11. I only had one **scent** left from the change I received.
12. My **ant** Sophie is coming to visit us next weekend.
13. We took a picture of the prize-winning **flower**.
14. Our teacher told us not to try to feed the **bare**.
15. I offered the rabbit a **bury**, but the rabbit ran away.
16. My dog smelled the **sent** of another dog on my coat.
17. I need to get a long **chord** to wrap around the package.
18. My dad says he can't wait until I **urn** my own money.
19. The big, black **aunt** was crawling across the floor.
20. When we opened the door, a big **be** flew inside.

Homophones are two or more words that sound alike but are spelled differently and have different meanings.

Name _____ Date _____

Hidden Homophone

Instructions – In each of the following sentences there is a “hidden homophone.” Find this “hidden homophone,” underline it, and write it as you found it in the blank next to the scrambled word in the parenthesis.

1. My mother has a red, ruby ring she wears when she goes out.

(bury) _____

2. I had only five cents left after I spent my weekly allowance on a gift for my mom.

(scent) _____

3. When it began to rain, we all had to run quickly for cover in the clubhouse.

(urn) _____

4. My brother sits in the sun every day in order to get a tan.

(ant) _____

5. The photographer told me to turn my face “a wee bit more to the right.”

(ewe) _____

Homophones are two or more words that sound alike but are spelled differently and have different meanings.

Name _____ Date _____

Make Your Own Homophone

Instructions – In the boxes below, draw a picture of your favorite homophone pairs. Write the name of each homophone under each picture.

--	--

--	--

© 1997 Super Duper® Publications 1-800-277-8737

Homophones are two or more words that sound alike but are spelled differently and have different meanings.

Name _____ Date _____

Homophone Crossword Puzzle

Instructions – Have fun filling in the crossword puzzle. Each of the answers is a homophone. You may choose your answers from the word list below.

aunt - ant
beet - beat
bee - be

berry - bury
cent - sent - scent
cord - chord

ail - ale
bear - bare
eye - I

flower - flour
urn - earn
ewe - you

Across

1. To place in the ground and cover with dirt
2. Wearing nothing
3. To be sick
4. A female relative
5. A red vegetable
8. To obtain money by working
9. A smell or odor
10. A part of your face
11. A sweet smelling thing that grows in your garden

Down

1. To strike with force
4. A crawling insect
5. Birds eat one
6. A drink that tastes like beer
7. A sheep
9. Opposite of received
12. A small rope or string

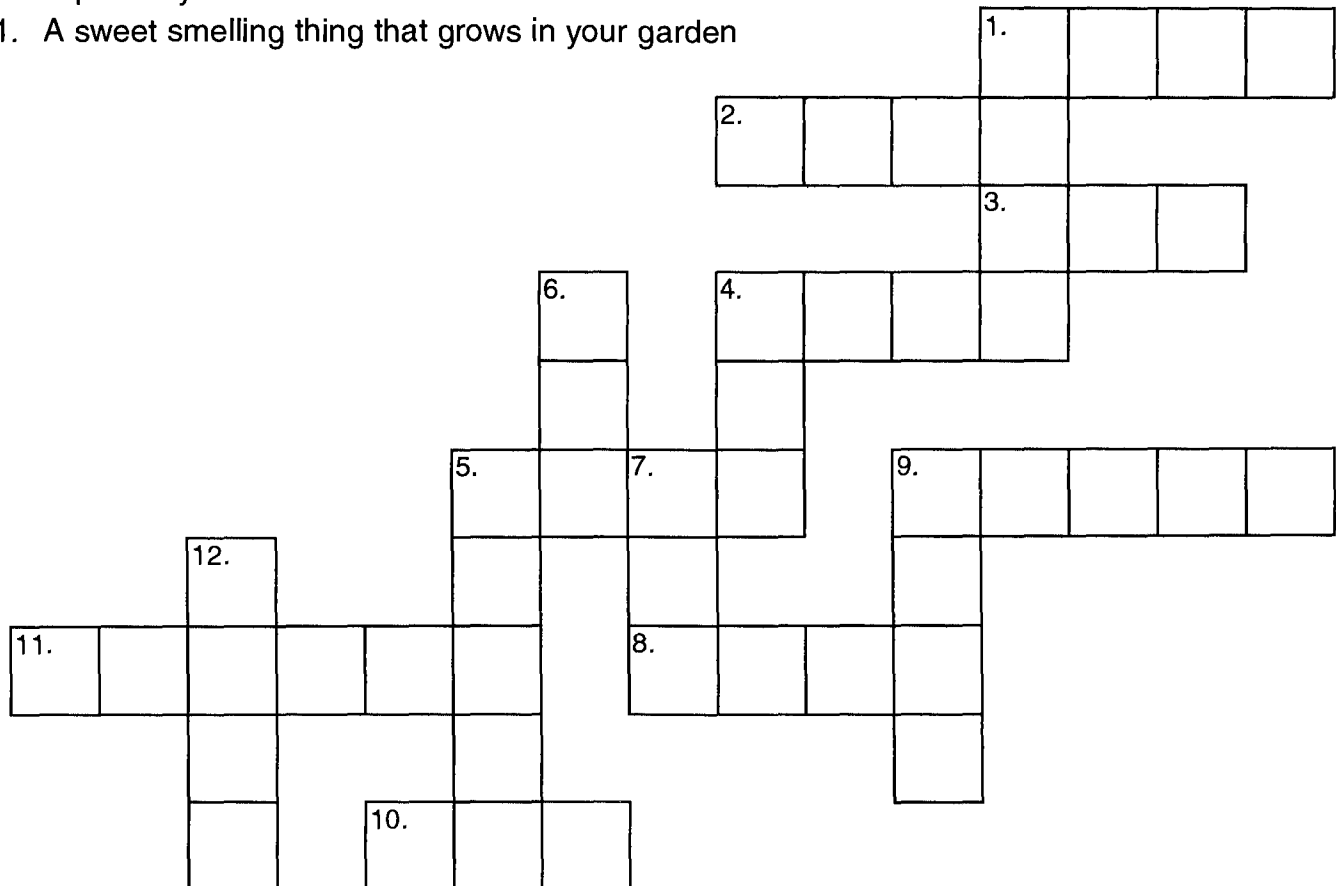

Homophones are two or more words that sound alike but are spelled differently and have different meanings.

Name _____ Date _____

Homophones

Homophones are two or more words that sound alike but are spelled differently and have different meanings.

Instructions – Here is a list of homophones for this lesson. Read them out loud so you can hear that they sound alike.

- | | |
|-----------------------|------------------------|
| 1. raise - rays | 7. rain - rein - reign |
| 2. vein - vane - vain | 8. too - to - two |
| 3. road - rode | 9. towed - toad |
| 4. forth - fourth | 10. steel - steal |
| 5. here - hear | 11. seam - seem |
| 6. tied - tide | 12. waist - waste |

Choose the Correct Homophone

Instructions – Read the sentences below and fill in the blanks with the correct homophones. You may look in the dictionary after you complete this exercise to see if you chose the right homophone. Correct any mistakes by crossing out or erasing your first answer and writing in the correct homophone.

- In our class, our teacher won't answer any questions from us unless we _____ our hands first.
(rays, raise)
- The _____ from the noonday sun were so strong that we had to sit under a beach umbrella.
(rays, raise)
- When my mom cleans the shrimp, she always removes the black _____ that runs down the shrimp's back.
(vain, vein, vane)
- The weather _____ on top of the roof shows you which way the wind is blowing.
(vane, vein, vain)
- My cousin Gail is so _____ she can't pass a mirror without stopping to admire herself.
(vein, vane, vain)
- My friend, Dave, and I _____ our bikes two miles today.
(rode, road)
- We drove carefully since the _____ was wet and muddy.
(road, rode)
- "Please step _____ and collect your prizes," the principal told the students who participated in the contest.
(forth, fourth)
- I told my friend I would be sitting in the _____ row.
(forth, fourth)
- I didn't _____ the fire truck until I opened my bedroom window.
(here, hear)
- "Why don't you have the party _____ in our house?" my mother said.
(here, hear)
- Because the _____ was so low today, we didn't go swimming in the ocean.
(tied, tide)

Homophones are two or more words that sound alike but are spelled differently and have different meanings.

Name _____ Date _____

Choose the Correct Homophone

Continued

13. I _____ the rope tightly around the pole so my dog wouldn't get loose this time.
(tide, tied)
14. The instructor told me how to hold each _____ to control the horse.
(rein, rain, reign)
15. The game was cancelled when it began to _____ hard.
(reign, rain, rein)
16. The king held his _____ of power for fifty years.
(rain, reign, rein)
17. I had _____ much cake and ice cream, and I felt sick
(to, two, too)
18. When I get out of high school I plan _____ join the army.
(to, two, too)
19. There are _____ more days left of my vacation.
(to, two, too)
20. A _____ looks like a frog, but it has a rougher, drier skin.
(toad, towed)
21. We had to have our car _____ when it broke down today.
(toad, towed)
22. My dad told me his razor blade is made of _____ .
(steal, steel)
23. The thief was about to _____ the money, but he was caught before he could do it.
(steel, steal)
24. It doesn't _____ like winter because the weather is so warm here.
(seam, seem)
25. My mother said the rip in my shirt was easy to repair since she just had to sew the _____ .
(seem, seam)
26. My mom said she had the same size _____ as mine when she was fifteen.
(waste, waist)
27. I don't like to _____ food so I eat everything on my plate including all the vegetables.
(waist, waste)

Homophones are two or more words that sound alike but are spelled differently and have different meanings.

Name _____ Date _____

Name The Homophones

Instructions – Look at each set of pictures below. Choose the correct homophones for each set from the word list, and write them in the spaces provided.

towed - toad
rays - raise

road - rode
waist - waste

rain - rein
too - two

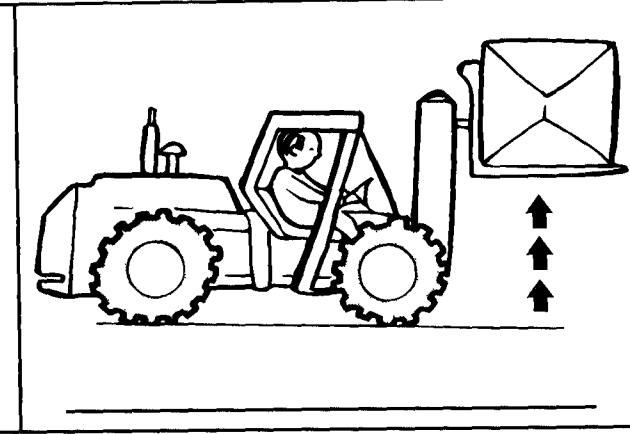
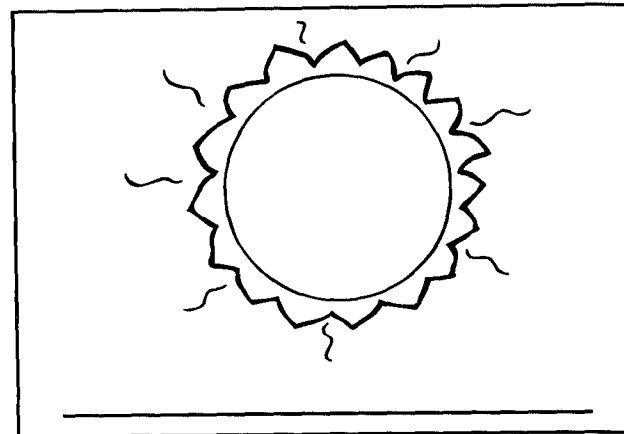
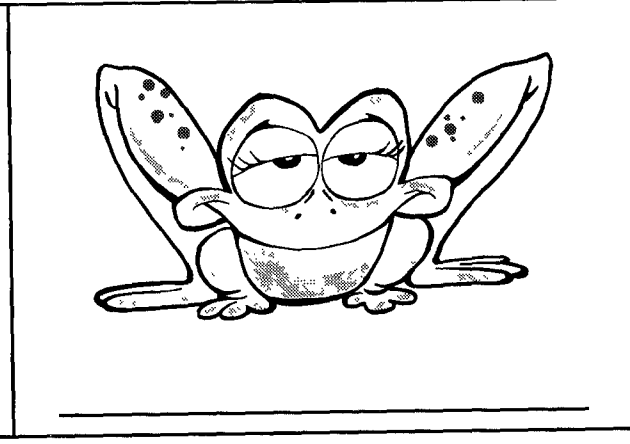
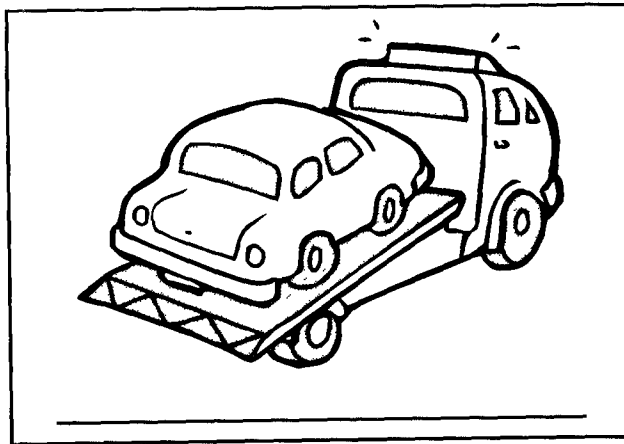
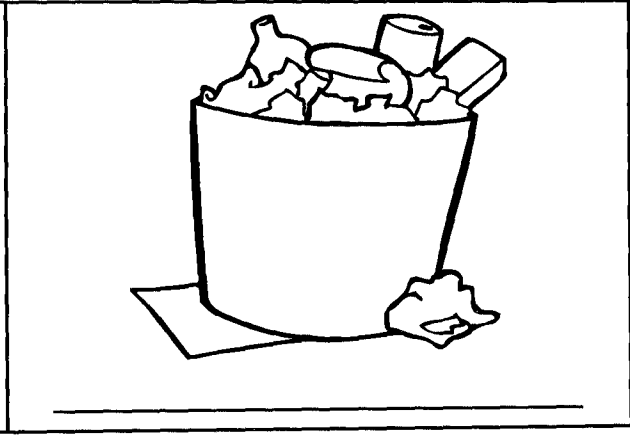
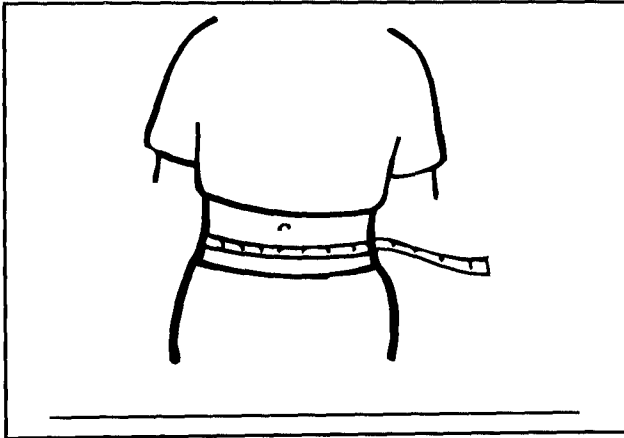

Homophones are two or more words that sound alike but are spelled differently and have different meanings.

Name _____ Date _____

Name The Homophones

Instructions – Look at each set of pictures below. Choose the correct homophones for each set from the word list, and write it in the spaces provided.

towed - toad
rays - raise

road - rode
waist - waste

rain - rein
too - two

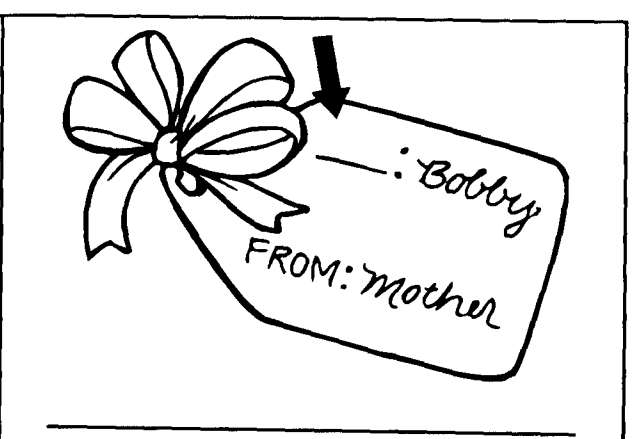
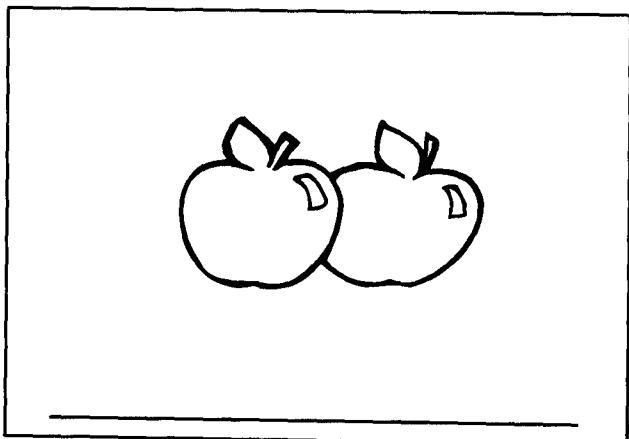
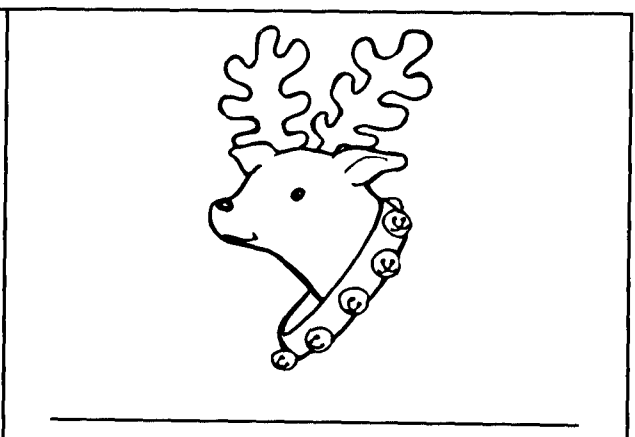
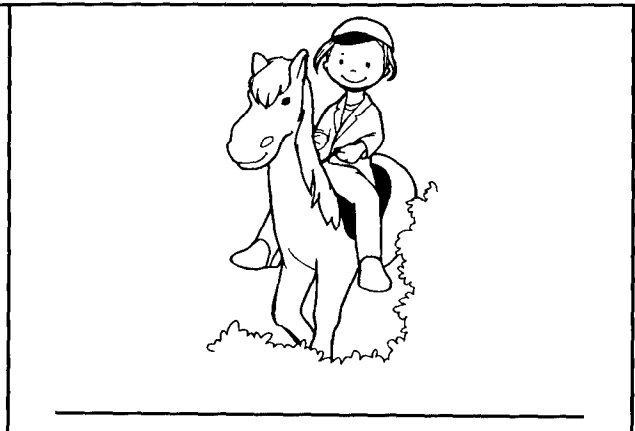
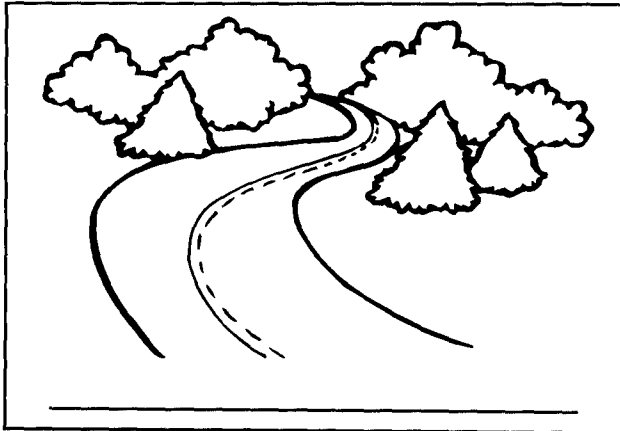

Homophones are two or more words that sound alike but are spelled differently and have different meanings.

Name _____ Date _____

Which Homophone Is It?

Instructions – Which one is it? Circle the correct homophone for each sentence.

1. They were going to do this to the flag today.
Answer: raise it, rays it
2. This is a vessel that carries blood to the heart.
Answer: vein, vain, vane
3. I live near a main one of these.
Answer: rode, road
4. In July, a holiday falls on this day.
Answer: the forth, the fourth
5. This is what we do with our ears.
Answer: here, hear
6. What you did to the shoelaces on your sneakers.
Answer: tide them, tied them
7. A king or queen does this in certain countries.
Answer: rain, rein, reign
8. This word means also.
Answer: to, too, two
9. These creatures have gills and are called amphibians.
Answer: towed, toad
10. A sword is made of this material.
Answer: steal, steel
11. A tailor sews two pieces of material together along this edge.
Answer: a seam, a seem
12. We throw this in the garbage can or trash basket.
Answer: waste, waist

Homophones are two or more words that sound alike but are spelled differently and have different meanings.

Name _____ Date _____

Correction Time

Instructions – Some of the homophones in the sentences below are correct, and some are wrong. If the homophone is correct, leave the sentence alone. If the homophone is wrong, cross it out and write the correct word above the wrong one.

1. The weather **vein** on top of the roof was pointed north.
2. We were the **fourth** ones in line waiting for tickets.
3. Up ahead the **rode** curved sharply to the left.
4. My little brother **tide** his shoelace into a tight knot.
5. The **rein** came down fast and we all had to run for cover.
6. I don't like to **here** bad things about my friends.
7. When we played musical chairs, there were only **too** of us left and we both thought we would win.
8. The **towed** jumped up on the chair and scared us.
9. The crow flew over to **steel** the bread before the sparrows got to it.
10. The guest speaker was so interesting it didn't **seam** like he was speaking for a whole hour.
11. I had **two** much homework to do so I didn't go to the movies.
12. It was a **waist** of time to try to convince my friend that he was wrong.
13. We **road** all day and finally got to the cabin by nighttime.
14. Our efforts were in **vain**; we couldn't find the lost ring.
15. Three of us tried to **rays** the window shade, but it wouldn't budge.
16. If you can't be **hear** on time, then don't come at all.
17. From afar the knife looked like it was made of **steal**, but it was really made of rubber.
18. My new leather belt was too big for my **waste**.
19. My **vane** cousin Cynthia is always combing her hair in the mirror.
20. I had to clean my room before I was allowed **too** go to the game.

Homophones are two or more words that sound alike but are spelled differently and have different meanings.

Name _____ Date _____

Hidden Homophone

Instructions – In each of the following sentences there is a “hidden homophone.” Find this “hidden homophone,” underline it, and write it as you found it in the blank next to the scrambled word in the parenthesis.

1. My dog chased the hare, but he was too swift for my dog to catch.

(hear) _____

2. When my aunt goes on a diet, it only lasts for a few weeks.

(tide) _____

3. Of all my friends, I had the least amount of cavities.

(steal) _____

4. Three of my classmates were reporting on the same President as I was.

(seam) _____

5. My cat always waits on the window sill when I come home.

(waist) _____

Homophones are two or more words that sound alike but are spelled differently and have different meanings.

Name _____ Date _____

Make Your Own Homophone

Instructions – In the boxes below, draw a picture of your favorite homophone pairs. Write the name of each homophone under each picture.

--	--

--	--

Homophones are two or more words that sound alike but are spelled differently and have different meanings.

Name _____ Date _____

Homophone Crossword Puzzle

Instructions – Have fun filling in the crossword puzzle. Each of the answers is a homophone.
 You may choose your answers from the word list below.

raise - rays
 vein - vane - vain
 road - rode

forth - fourth
 here - hear
 rain - rein - reign

tide - tied
 too - to - two
 towed - toad

steel - steal
 seam - seem
 waist - waste

Across

1. Water that comes from clouds
3. Beams of light
4. A king's term of power
5. Garbage or trash
7. You sew together two pieces of material along this line
8. You wear a belt around this part
9. Your ears allow you to do this
11. When you take what doesn't belong to you
12. Double

Down

1. A path cars travel on
2. Too much pride in your own appearance
3. To lift
6. Pulled along behind by a chain
7. A hard, strong material often used on construction
10. The past tense of ride
12. A creature that looks like a frog
13. Also

The crossword puzzle grid consists of the following numbered squares:

- Across:** 1 (row 3, col 4), 3 (row 2, col 7), 4 (row 4, col 6), 5 (row 3, col 5), 7 (row 5, col 4), 8 (row 6, col 4), 9 (row 7, col 6), 11 (row 8, col 7), 12 (row 9, col 7).
- Down:** 1 (row 1, col 5), 2 (row 1, col 6), 3 (row 2, col 7), 6 (row 3, col 5), 7 (row 3, col 6), 8 (row 4, col 5), 9 (row 5, col 6), 10 (row 5, col 7), 12 (row 8, col 7), 13 (row 8, col 8).

© 1997 Super Duper® Publications 1-800-277-8737

Homophones are two or more words that sound alike but are spelled differently and have different meanings.

Name _____ Date _____

Homophones

Homophones are two or more words that sound alike but are spelled differently and have different meanings.

Instructions – Here is a list of homophones for this lesson. Read them out loud so you can hear that they sound alike.

- | | |
|----------------------|--------------------|
| 1. ate - eight | 7. cheap - cheep |
| 2. bough - bow | 8. flee - flea |
| 3. blue - blew | 9. fowl - foul |
| 4. by - buy | 10. arc - ark |
| 5. knot - not | 11. knight - night |
| 6. capital - capitol | 12. bald - bawled |

Choose the Correct Homophone

Instructions – Read the sentences below and fill in the blanks with the correct homophones. You may look in the dictionary after you complete this exercise to see if you chose the right homophone. Correct any mistakes by crossing out or erasing your first answer and writing in the correct homophone.

1. I think my brother _____ the piece of pie I left in the refrigerator.
(eight, ate)
2. There are only _____ people in my class who passed the test.
(ate, eight)
3. The _____ of the old oak tree broke and fell off during the hurricane.
(bough, bow)
4. My friend asked me if he should _____ when he meets the princess this summer.
(bough, bow)
5. The _____ paint was what I chose for my bedroom walls.
(blue, blew)
6. When they turned out the lights, I _____ out the candles on my birthday cake.
(blew, blue)
7. I'm going _____ your house today, so I'll drop off the book I borrowed.
(by, buy)
8. I won't _____ anything I don't need when I go shopping at the mall.
(by, buy)
9. I do _____ like to play chess with my friend because he always wins.
(not, knot)
10. I tried hard, but I couldn't loosen the _____ in my necklace chain.
(not, knot)
11. My teacher reminded me to use a _____ at the beginning of each sentence I wrote.
(capitol, capital)
12. This summer we will visit the _____ .
(capital, Capitol)

Homophones are two or more words that sound alike but are spelled differently and have different meanings.

Name _____ Date _____

Choose the Correct Homophone

Continued

13. The calculator was so _____ it broke two weeks after I bought it.
(cheep, cheap)
14. We heard a _____ coming from the box and we knew that a baby chick was inside.
(cheap, cheep)
15. The horses had to _____ from the burning barn.
(flee, flea)
16. We saw the _____ jump off our dog Sparky's back.
(flea, flee)
17. My uncle doesn't eat red meat, he only eats _____.
(foul, fowl)
18. The _____ smell in the motel room was a result of the broken sewer pipes.
(fowl, foul)
19. After the rainstorm, a noticeable rainbow formed an _____ on the pavement.
(arc, ark)
20. In the Bible it is said that Noah built an _____ to save himself, his family, and the animals from a flood that covered the earth.
(ark, arc)
21. A _____ wore metal armor to protect himself during battle.
(night, knight)
22. Every _____ I do ten minutes of exercise before I go to bed.
(knight, night)
23. My father told me he turned _____ at the age of twenty-eight.
(bawled, bald)
24. My brother _____ when mom told him to give his twin sister her toy back.
(bald, bawled)

Homophones are two or more words that sound alike but are spelled differently and have different meanings.

Name _____ Date _____

Name The Homophones

Instructions – Look at each set of pictures below. Choose the correct homophones for each set from the word list, and write them in the spaces provided.

arc - ark
bawled - bald

cheep - cheap
knight - night

eight - ate
blue - blew

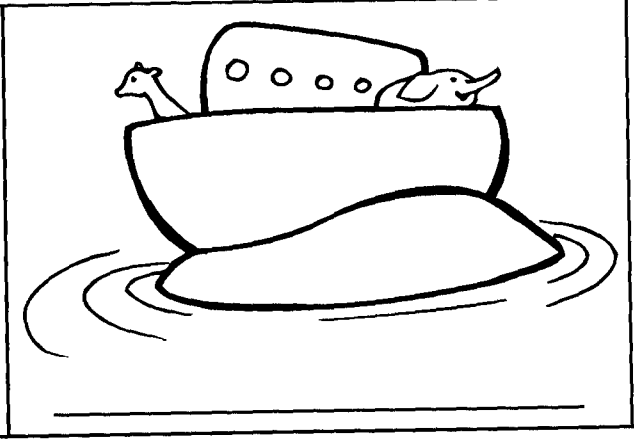
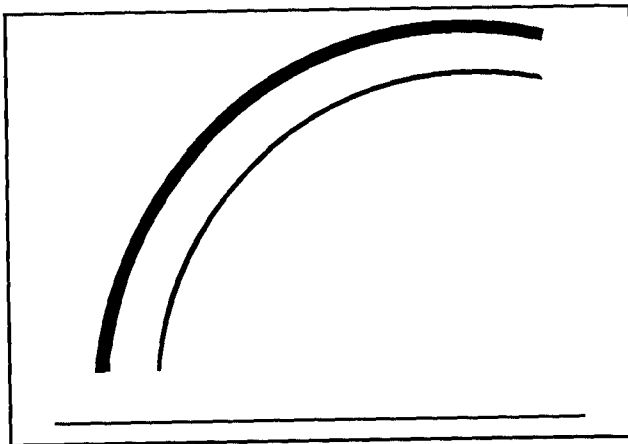
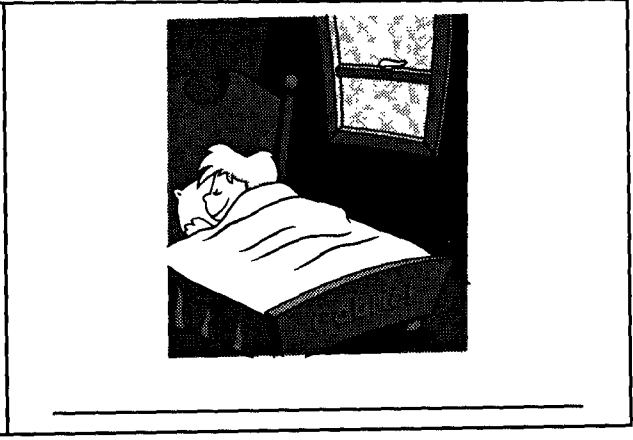
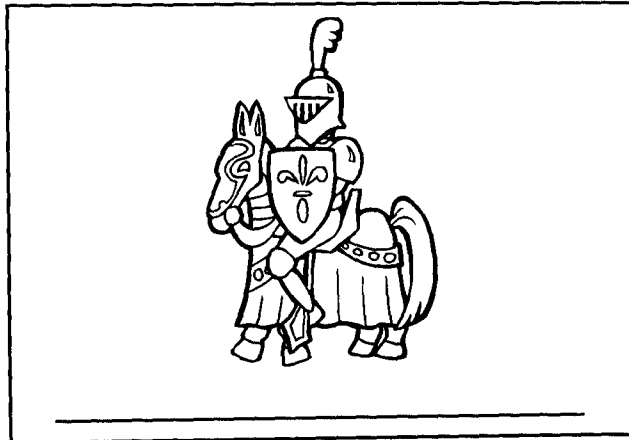

Homophones are two or more words that sound alike but are spelled differently and have different meanings.

Name _____ Date _____

Name The Homophones

Instructions – Look at each set of pictures below. Choose the correct homophones for each set from the word list, and write it in the spaces provided.

arc - ark
bawled - bald

cheep - cheap
knight - night

eight - ate
blue - blew

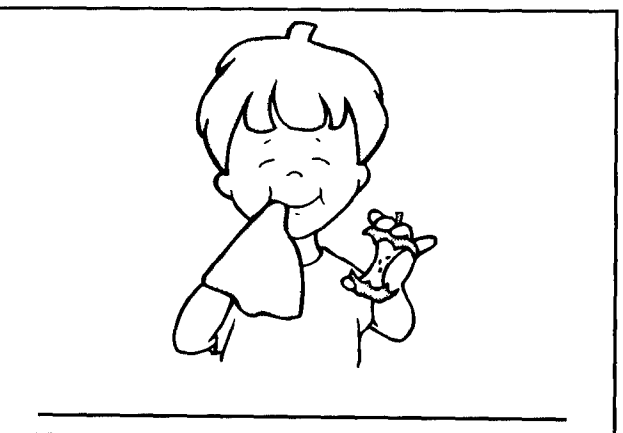
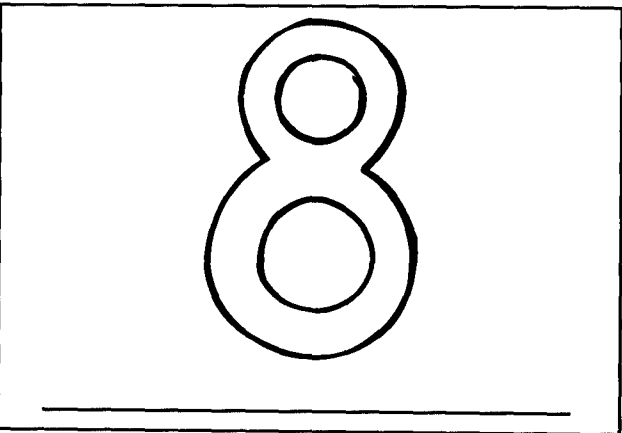
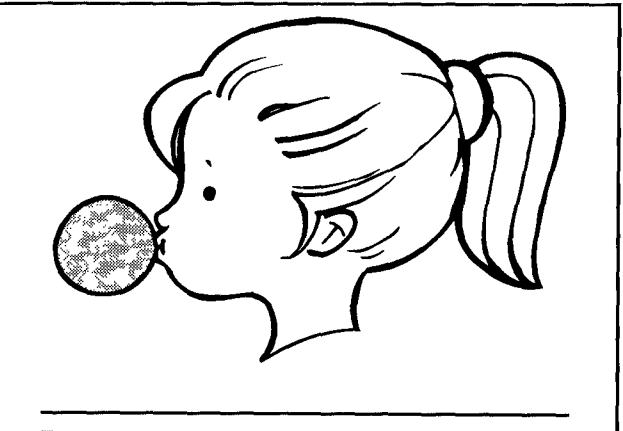
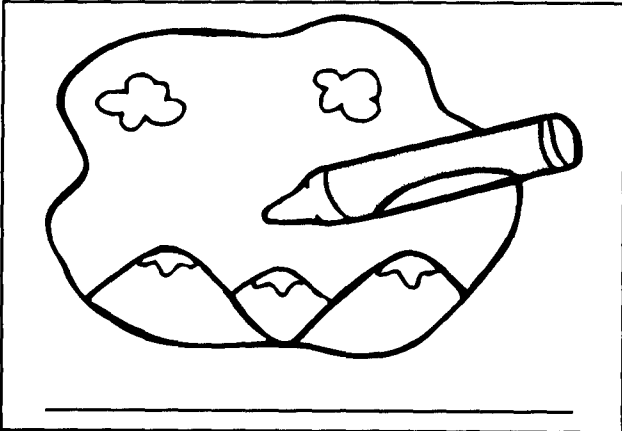
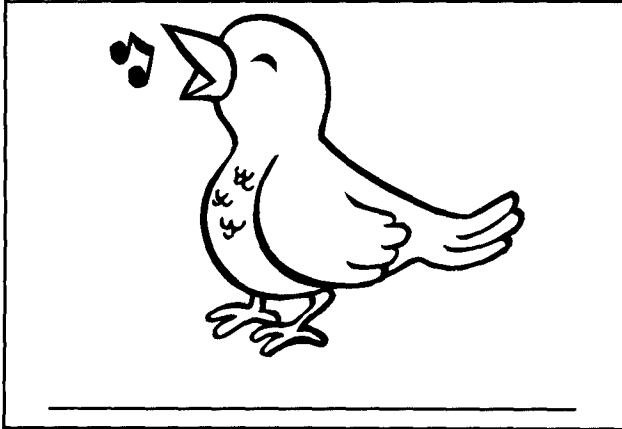

Homophones are two or more words that sound alike but are spelled differently and have different meanings.

Name _____ Date _____

Which Homophone Is It?

Instructions – Which one is it? Circle the correct homophone for each sentence.

1. This is what you may have done to your finger after you burned it.
Answer: blew on it, blue on it
2. You could hang a swing on this thing on your big tree.
Answer: a bough, a bow
3. You did this with your dinner last night.
Answer: ate it, eight it
4. When you pay for things you take home from the store, you do this.
Answer: buy them, by them
5. When we tie together two pieces of string or cord, we may make this.
Answer: a not, a knot
6. The U.S. government (congress) meets in this building in Washington D.C.
Answer: the Capital, the Capitol
7. When the sun goes down and it is dark outside, it is this time.
Answer: knight, night
8. Something which is inexpensive or not worth much is this.
Answer: cheep, cheap
9. A small, pesty insect that lives on dogs and cats is this.
Answer: a flee, a flea
10. A chicken, duck, or turkey is called this.
Answer: a fowl, a foul
11. A curved line on a circle is called this.
Answer: an arc, an ark
12. When someone has no hair on his/her head, he/she is called this.
Answer: bald, bawled

Homophones are two or more words that sound alike but are spelled differently and have different meanings.

Name _____ Date _____

Correction Time

Instructions – Some of the homophones in the sentences below are correct, and some are wrong. If the homophone is correct, leave the sentence alone. If the homophone is wrong, cross it out and write the correct word above the wrong one.

1. I described the man as being tall, with a grey beard and a **bawled** head.
2. Every **knight** I watch the 6:00 P.M. news with my family.
3. At the end of the play, our teacher told us to take a **bough** for the audience.
4. I do **knot** want to change my appointment for today.
5. “Why don’t you **by** that book?” my friend asked.
6. I saw the **flea** crawling on my dog’s head.
7. The air in the room smelled **fowl** because so many people had been smoking there.
8. We **blew** out all the candles and turned on the lamp.
9. The dress was so **cheep**, my mother couldn’t resist buying it.
10. I **eight** all my meat, but left the vegetables.
11. We saw a painting of Noah’s **arc** in the museum.
12. I have a habit of printing, rather than writing, the **capital** letters in my first and last names.
13. I got three **blew** sweaters as presents last Christmas.
14. The little boy’s shoelace had such a tight **knot** in it, it took a long time to loosen it.
15. I walk **buy** the old, abandoned building every day on my way home from school.
16. I’ll come by your house at **ate** o’clock tonight.
17. The criminal had to **flee** from the scene of the crime.
18. The **night** was brave when he went into battle.
19. My mom asked my dad if he wanted fish or **fowl** for dinner.
20. My cat sat on the **bow** of the tree and we couldn’t coax her down.

Homophones are two or more words that sound alike but are spelled differently and have different meanings.

Name _____ Date _____

Hidden Homophone

Instructions – In each of the following sentences there is a “hidden homophone.” Find this “hidden homophone,” underline it, and write it as you found it in the blank next to the scrambled word in the parenthesis.

1. My favorite summertime fruit is the peach.

(cheap) _____

2. We heard the wolf howling in the night.

(fowl) _____

3. My father painted the old car and it looked like new.

(arc) _____

4. My little sister stood outside for an hour trying to catch a leaf falling from the tree.

(flea) _____

5. Every night my grandma has a cup of tea before she goes to bed.

(ate) _____

Homophones are two or more words that sound alike but are spelled differently and have different meanings.

Name _____ Date _____

Make Your Own Homophone

Instructions – In the boxes below, draw a picture of your favorite homophone pairs. Write the name of each homophone under each picture.

--	--

--	--

Homophones are two or more words that sound alike but are spelled differently and have different meanings.

Name _____ Date _____

© 1997 Super Duper® Publications 1-800-277-8737

Homophone Crossword Puzzle

Instructions – Have fun filling in the crossword puzzle. Each of the answers is a homophone. You may choose your answers from the word list below.

ate - eight
bough - bow
blue - blew

by - buy
knot - not
capital - capitol

cheap - cheep
flee - flea
fowl - foul

arc - ark
knight - night
bald - bawled

Across

- 2. A chicken
- 3. You begin a sentence with this letter
- 6. A person who wore armor and fought in battles
- 8. A crayon color
- 9. Not much money
- 11. A number
- 12. A negative word

Down

- 1. The sound a baby chick makes
- 2. An unpleasant smell
- 4. What you did at lunchtime
- 5. Noah and his family sailed in this
- 7. It's dark outside
- 8. A big tree branch
- 10. A curved line that makes a part of a circle

Homophones are two or more words that sound alike but are spelled differently and have different meanings.

Name _____ Date _____

Homophones

Homophones are two or more words that sound alike but are spelled differently and have different meanings.

Instructions – Here is a list of homophones for this lesson. Read them out loud so you can hear that they sound alike.

- | | |
|---------------------------|-------------------|
| 1. wear - where | 7. groan - grown |
| 2. write - right | 8. soar - sore |
| 3. root - route | 9. know - no |
| 4. prays - praise - preys | 10. knows - nose |
| 5. plane - plain | 11. witch - which |
| 6. patience - patients | 12. way - weigh |

Choose the Correct Homophone

Instructions – Read the sentences below and fill in the blanks with the correct homophones. You may look in the dictionary after you complete this exercise to see if you chose the right homophone. Correct any mistakes by crossing out or erasing your first answer and writing in the correct homophone.

1. I can't remember _____ I put my homework assignment.
(wear, where)
2. My big sister always says she doesn't have a thing to _____.
(where, wear)
3. I'm going to _____ a letter to my pen pal today.
(right, write)
4. I know I didn't get the first answer _____ on that test.
(write, right)
5. My tomato plant began to take _____ finally.
(root, route)
6. I went along with my friend on his newspaper _____ today.
(root, route)
7. My uncle, who's a farmer, always _____ for rain when there's a drought.
(praise, preys, prays)
8. You have to _____ a dog often in order to teach it new tricks.
(prays, praise, preys)
9. An owl _____ on a mouse for food.
(prays, preys, praise)
10. For dessert my mother ordered strawberry short cake, and I ordered _____ pound cake.
(plane, plain)
11. My grandfather's _____ was scheduled to land in an hour.
(plain, plane)
12. The waiting room was filled with _____ when we got there.
(patients, patience)

Homophones are two or more words that sound alike but are spelled differently and have different meanings.

Name _____ Date _____

Choose the Correct Homophone

Continued

13. My dad doesn't have the _____ to wait in line for a popular movie.
(patients, patience)
14. I can't wait till my dog is full- _____ so I can enter him in a dog show.
(groan, grown)
15. My cousin started to _____ and said she had a stomach ache from eating so much cake.
(grown, groan)
16. We watched my uncle's jet _____ into the sky.
(sore, soar)
17. I had a _____ throat and knew I was getting a cold.
(soar, sore)
18. I don't _____ what I'm getting my friend for her birthday.
(no, know)
19. When I rang the bell, there was _____ answer.
(know, no)
20. Everyone except Joe _____ how to use a computer by now.
(knows, nose)
21. My _____ and eyes itch alot when there is alot of pollen.
(nose, knows)
22. I played the part of the good _____ in the school play.
(which, witch)
23. We couldn't decide _____ puppy to choose, so we bought them both.
(which, witch)
24. It's just my opinion, I have no _____ to prove it.
(weigh, way)
25. The post office had to _____ the package before I could send it.
(way, weigh)

Homophones are two or more words that sound alike but are spelled differently and have different meanings.

Name _____ Date _____

Name The Homophones

Instructions – Look at each set of pictures below. Choose the correct homophones for each set from the word list, and write them in the spaces provided.

right - write
knows - nose

plane - plain
root- route

witch - which
sore - soar

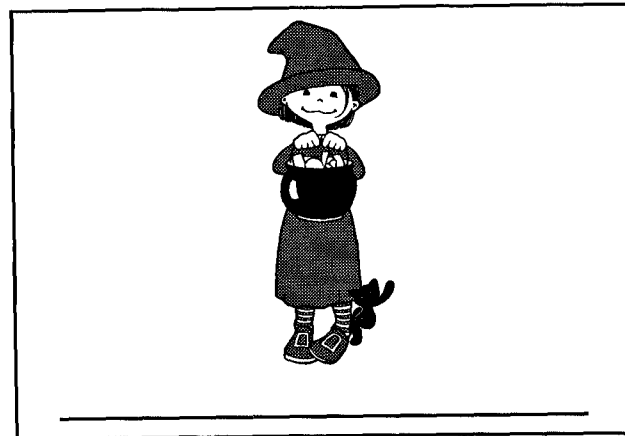
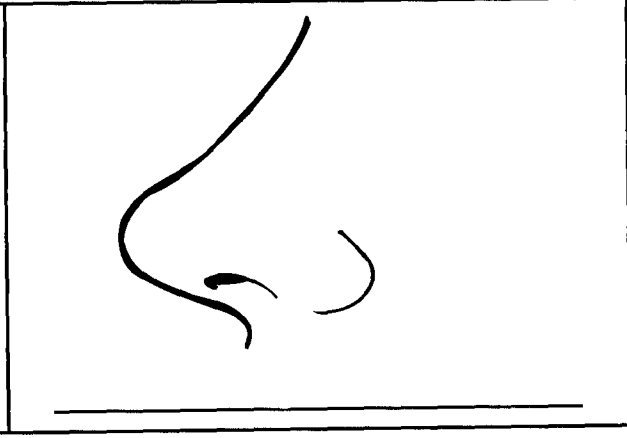
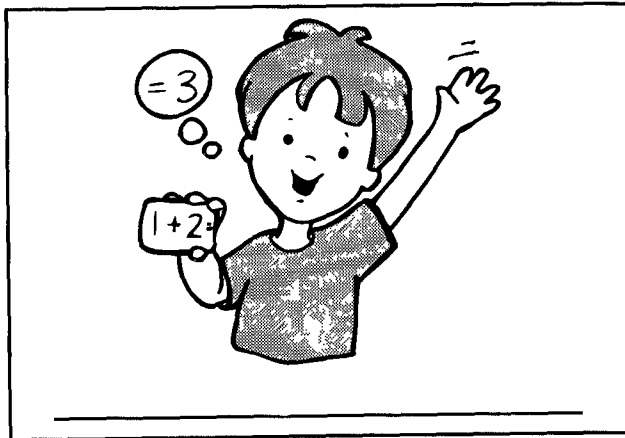
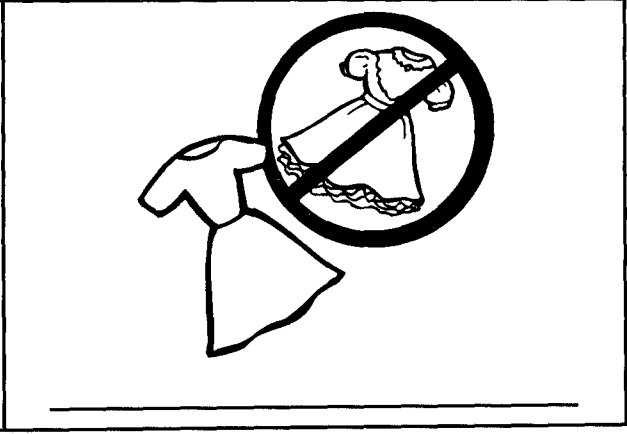
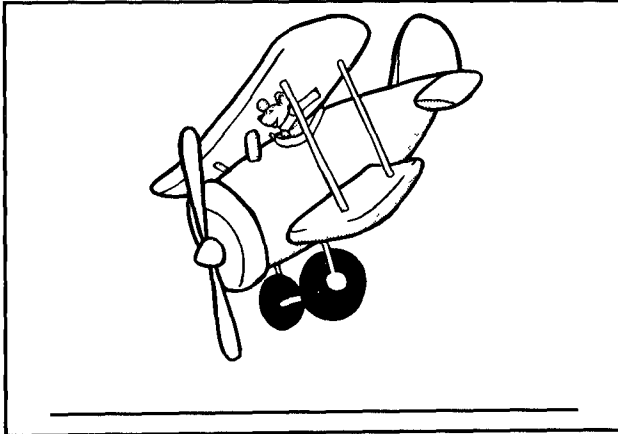

Homophones are two or more words that sound alike but are spelled differently and have different meanings.

Name _____ Date _____

Name The Homophones

Instructions – Look at each set of pictures below. Choose the correct homophones for each set from the word list, and write it in the spaces provided.

right - write
knows - nose

plane - plain
root - route

witch - which
sore - soar

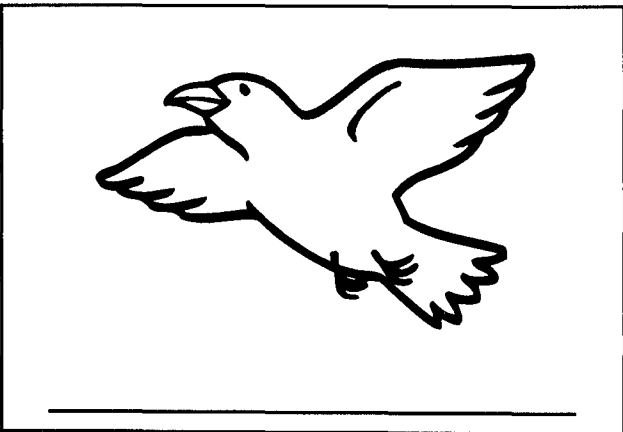
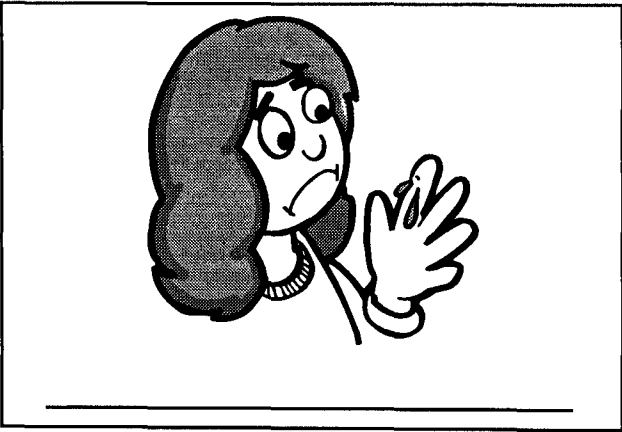
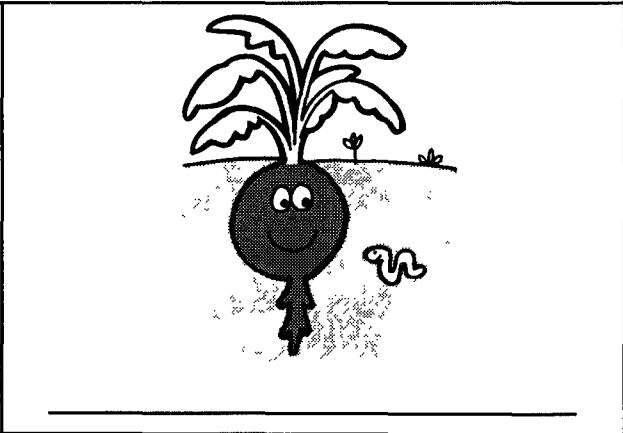
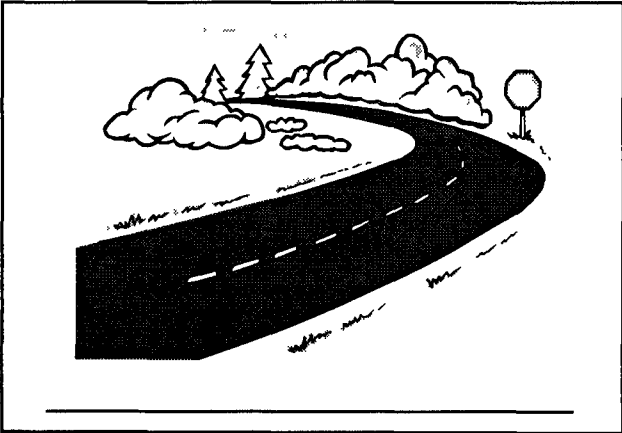
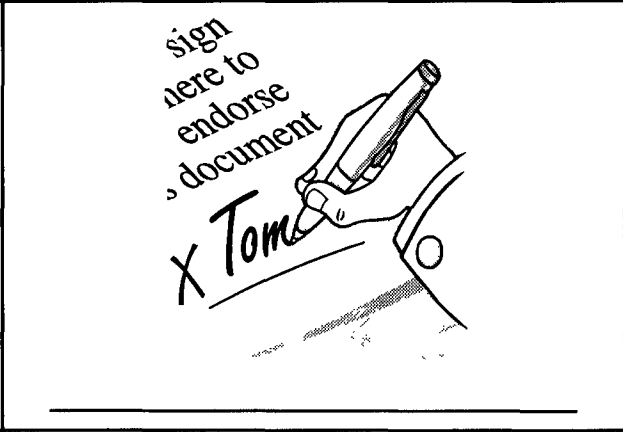
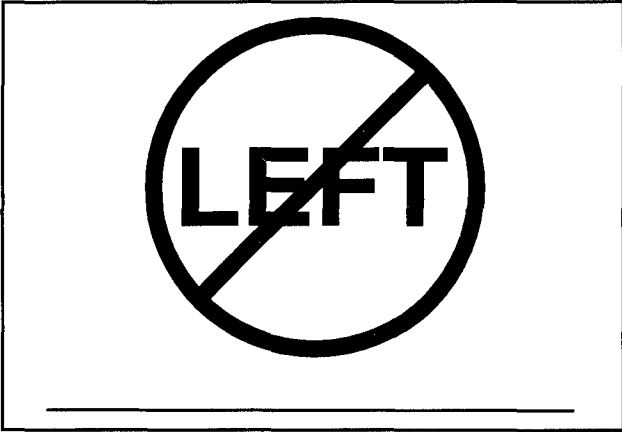

Homophones are two or more words that sound alike but are spelled differently and have different meanings.

Name _____ Date _____

Which Homophone Is It?

Instructions – Which one is it? Circle the correct homophone for each sentence.

1. I don't know whether to throw my jeans away or do this.

Answer: where them, wear them

2. The opposite of left is this.

Answer: write, right

3. The bus follows this everyday to school.

Answer: the root, the route

4. When a teacher likes what you did, she gives you this.

Answer: prays, preys, praise

5. When something is not fancy it is this.

Answer: plane, plain

6. You must have this when you are waiting for your presents.

Answer: patients, patience

7. When you reach your full height, then you are this.

Answer: full groan, full grown

8. Your finger will become this way if you slam a drawer on it.

Answer: soar, sore

9. You give a negative answer when you say this word.

Answer: know, no

10. This is an important part of your face.

Answer: knows, nose

11. If you want to know if it's one thing or the other, you say this.

Answer: witch one?, which one?

12. You may do this on a scale to find out how many pounds you have gained.

Answer: way yourself, weigh yourself

Homophones are two or more words that sound alike but are spelled differently and have different meanings.

Name _____ Date _____

Correction Time

Instructions – Some of the homophones in the sentences below are correct, and some are wrong. If the homophone is correct, leave the sentence alone. If the homophone is wrong, cross it out and write the correct word above the wrong one.

1. I asked the policeman if he knew **wear** Main Street was.
2. The **right** thing to do is not always the easy thing to do.
3. I had to pull each weed up by its **route**.
4. I don't know **witch** friend to give the free ticket to.
5. My friend said he didn't **no** whether he could come over tonight.
6. My friend **nose** all my faults, but still likes me the way I am.
7. When my mother began to **prays** me in front of my friends, I was embarrassed.
8. You need to have **patients** when you want to learn a foreign language.
9. I had trouble putting my shoe on because my foot was so **soar**.
10. My friend had a hot fudge sundae, but I had my ice cream **plane**.
11. When we heard we were having a surprise test today, some of the kids in the back of the class began to **grown**.
12. Since we had **know** more mayonnaise left, I put salad dressing on my turkey sandwich.
13. I didn't know **witch** shirt I liked better, so my mother said I should get both.
14. My dieting sister likes to **weigh** herself every morning to see if she has lost any more weight.
15. I should **where** my old shoes when it's raining, but I don't.
16. I always **route** for the player in second place when I watch golf on T.V.
17. The first time I flew on a **plain** I was very nervous.
18. My friend and I make a good team; he likes to **write** stories, and I like to draw pictures for them.
19. I like my neighbor's cat alot, except when it **prays** on the birds in the yard.
20. My uncle Jim only eats home-**groan** vegetables, never the ones from the grocery store.

Homophones are two or more words that sound alike but are spelled differently and have different meanings.

Name _____ Date _____

Hidden Homophone

Instructions – In each of the following sentences there is a “hidden homophone.” Find this “hidden homophone,” underline it, and write it as you found it in the blank next to the scrambled word in the parenthesis.

1. I have to spray my flowers often so they don't get eaten by insects.

(prays) _____

2. The panel consisted of six students and three teachers.

(plane) _____

3. I walked down the wrong hall and was late for my class.

(grown) _____

4. My mother was going to enter her pink rose in the flower show.

(sore) _____

5. There were no lights on so I didn't ring the bell.

(no) _____

Homophones are two or more words that sound alike but are spelled differently and have different meanings.

Name _____ Date _____

Make Your Own Homophone

Instructions – In the boxes below, draw a picture of your favorite homophone pairs. Write the name of each homophone under each picture.

--	--

--	--

Homophones are two or more words that sound alike but are spelled differently and have different meanings.

Name _____ Date _____

Homophone Crossword Puzzle

Instructions – Have fun filling in the crossword puzzle. Each of the answers is a homophone.
 You may choose your answers from the word list below.

wear - where
 write - right
 root - route

prays - praise - preys
 plane - plain
 patience - patients

groan - grown
 soar - sore
 know - no

knows - nose
 witch - which
 way - weigh

Across

1. To put something on your body
2. What a person does in a church or a temple
3. To give a compliment to someone
4. The underground part of a plant
6. What you do with a pen or pencil
8. When something or someone is mature
10. People that doctors and nurses treat
12. You do this to something on a scale
13. Ordinary or simple

Down

1. A road, path or highway
2. You have this when you wait for a long time
4. A road or course for travel
5. To rise upward into the air
7. Wordless sound that expresses pain or grief
9. To be certain
11. A mean, old, ugly woman or hag
13. A machine that flies
14. Hurting or painful to the touch

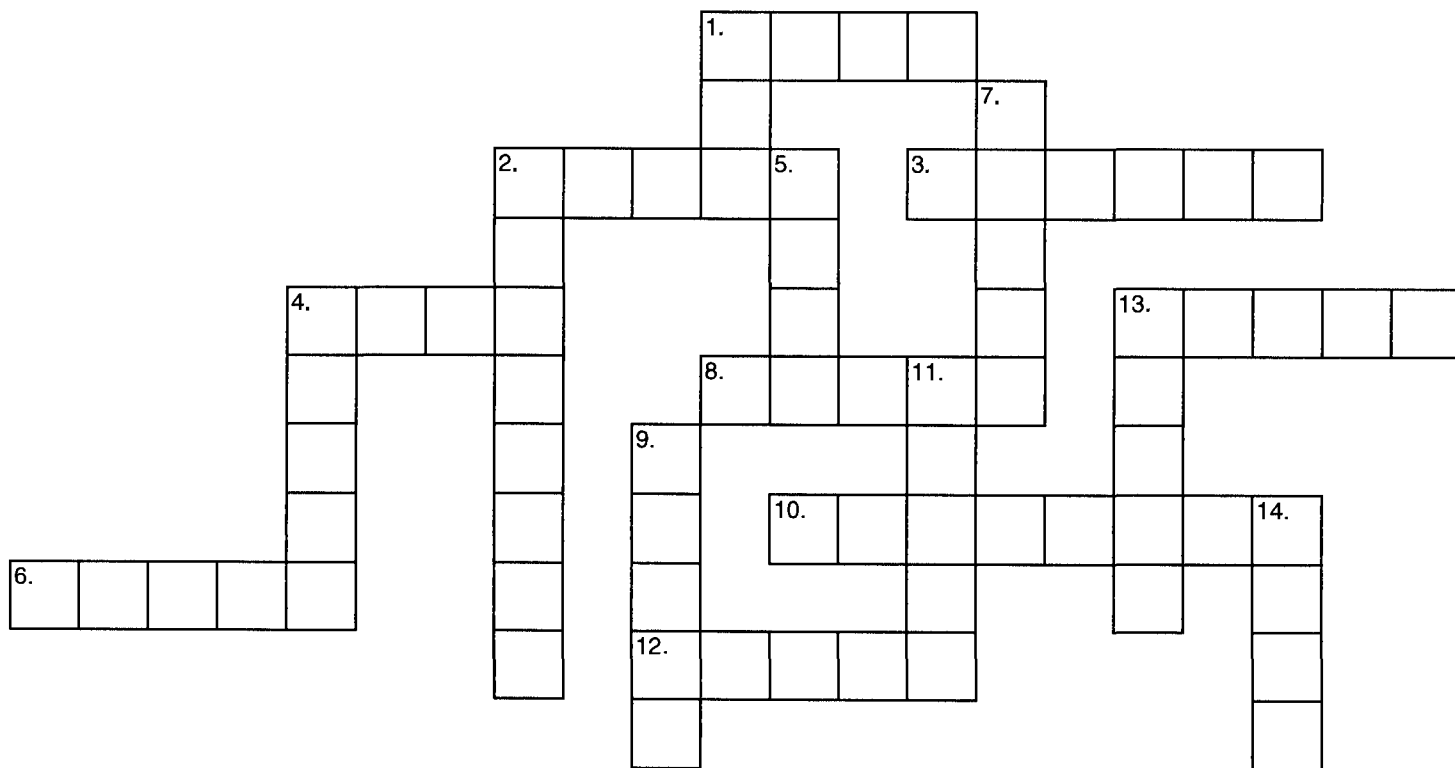

Homophones are two or more words that sound alike but are spelled differently and have different meanings.

Name _____ Date _____

Homophones

Homophones are two or more words that sound alike but are spelled differently and have different meanings.

Instructions – Here is a list of homophones for this lesson. Read them out loud so you can hear that they sound alike.

1. whole - hole

2. dye - die

3. lead - led

4. one - won

5. pair - pear

6. pail - pale

7. sea - see

8. pause - paws

9. hour - our

10. dense - dents

11. grate - great

12. their - there

Choose the Correct Homophone

Instructions – Read the sentences below and fill in the blanks with the correct homophones. You may look in the dictionary after you complete this exercise to see if you chose the right homophone. Correct any mistakes by crossing out or erasing your first answer and writing in the correct homophone.

1. I ate the _____ pint of ice cream and then felt sick.
(hole, whole)
2. The dog dug a _____ in the yard and buried his bone in it.
(whole, hole)
3. My mother said she would _____ my shirt a different color.
(die, dye)
4. The old Indian chief said he would _____ in a few weeks.
(dye, die)
5. There was no more _____ left in my new mechanical pencil.
(lead, led)
6. I _____ my thirsty horse to the water hole.
(led, lead)
7. I was sure I had _____ the contest of how many beans were in the jar.
(won, one)
8. I only had _____ piece of gum left.
(one, won)
9. I couldn't find my new _____ of socks.
(pair, pear)
10. My mom packed a tuna sandwich, a box of juice and a _____ for my lunch today.
(pear, pair)
11. My sister's face stayed _____ all summer because she stayed out of the sun.
(pale, pail)
12. My little brother always carried his new _____ and shovel when he went to visit his friend who lived near the beach.
(pail, pale)

Homophones are two or more words that sound alike but are spelled differently and have different meanings.

Name _____ Date _____

Choose the Correct Homophone

Continued

13. My brother likes to swim in the _____ but I like the pool.
(see, sea)
14. My bedroom window was so fogged up from the air conditioner, I couldn't _____ out of it.
(sea, see)
15. My cat's _____ were all wet when he came in from the rain.
(pause, paws)
16. My teacher said we would _____ for a short time before we started the second part of the test.
(paws, pause)
17. In another _____ we were going to be out of school for the start of the summer vacation.
(our, hour)
18. We thought it would be a good idea to give _____ teacher a surprise birthday party.
(our, hour)
19. The fog was so _____ we couldn't see one foot ahead of us.
(dents, dense)
20. The _____ in the fenders made the car look older than it was.
(dents, dense)
21. The quarter rolled into the _____ covering the sewer.
(grate, great)
22. I had a _____ time at my grandparents' farm last summer.
(grate, great)
23. My mom lets me _____ the potatoes for her potato pancakes.
(great, grate)
24. We asked our friend Butch to come with us to the old haunted house, but he said he would never go _____ again.
(there, their)
25. My neighbors always walk _____ dog past my house at 7:30 P.M. each night.
(there, their)

Homophones are two or more words that sound alike but are spelled differently and have different meanings.

Name _____ Date _____

Name The Homophones

Instructions – Look at each set of pictures below. Choose the correct homophones for each set from the word list, and write them in the spaces provided.

pair - pear
hole - whole

dye - die
one - won

pail - pale
see - sea

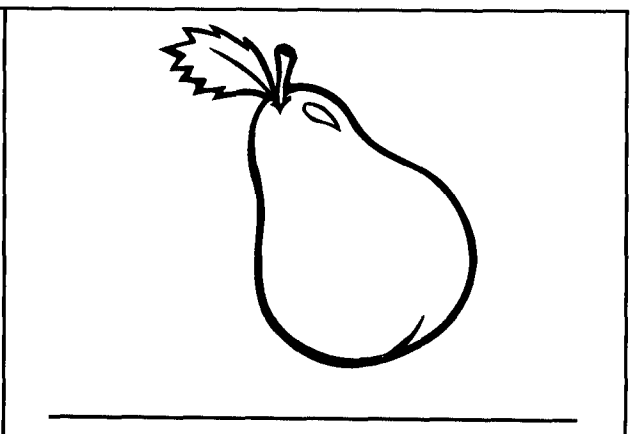
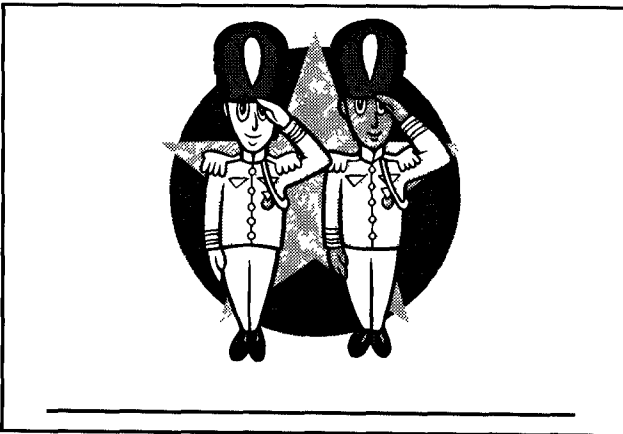
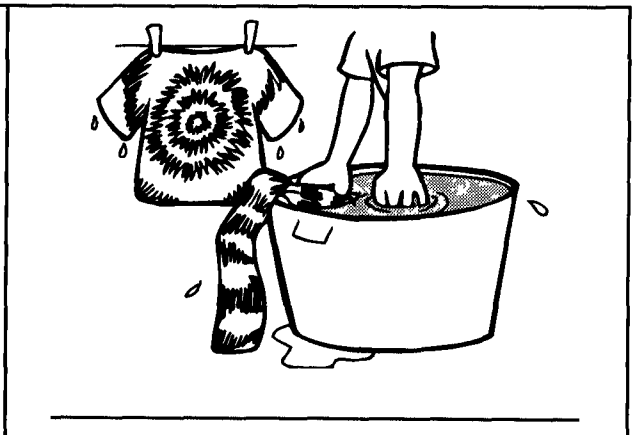
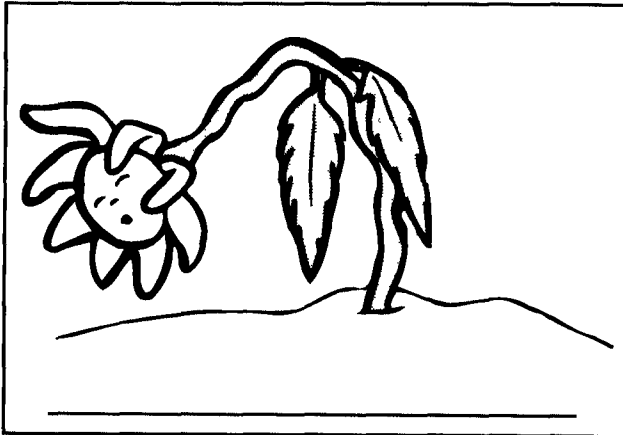
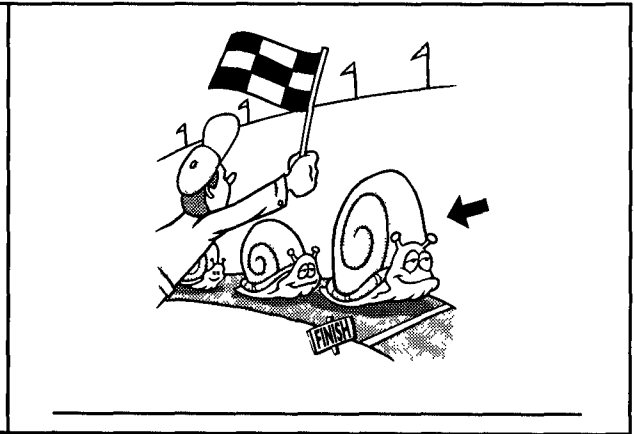
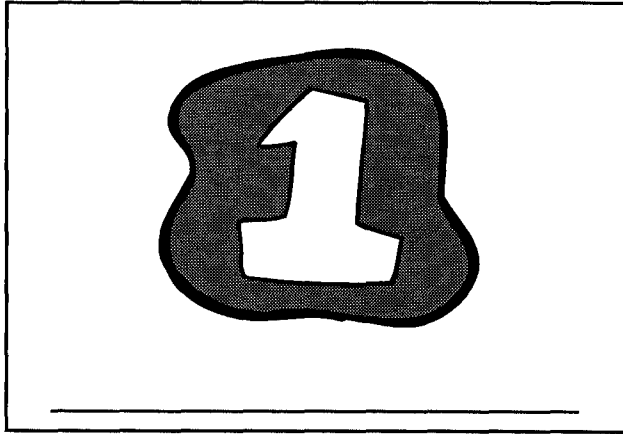

Homophones are two or more words that sound alike but are spelled differently and have different meanings.

Name _____ Date _____

Name The Homophones

Instructions – Look at each set of pictures below. Choose the correct homophones for each set from the word list, and write it in the spaces provided.

pair - pear

hole - whole

dye - die

one - won

pail - pale

see - sea

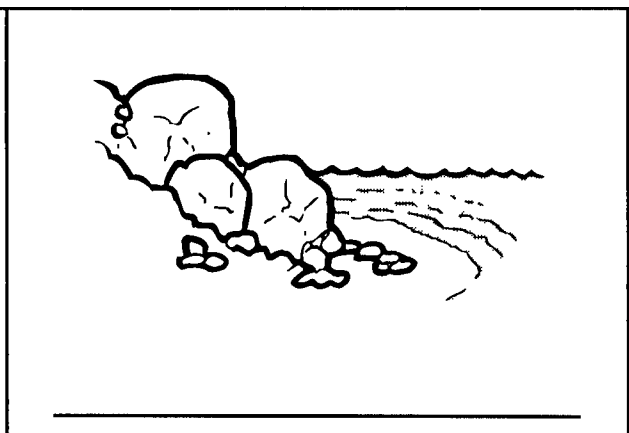
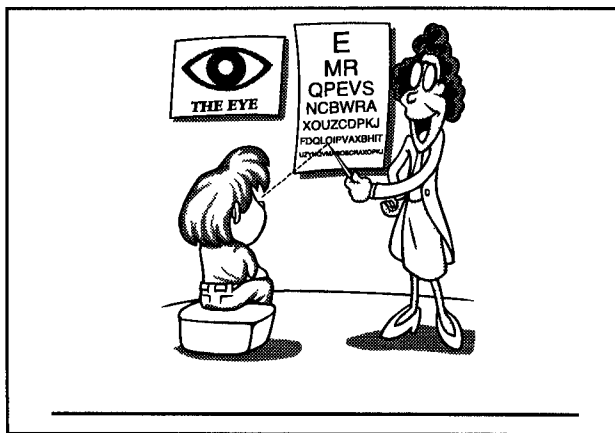
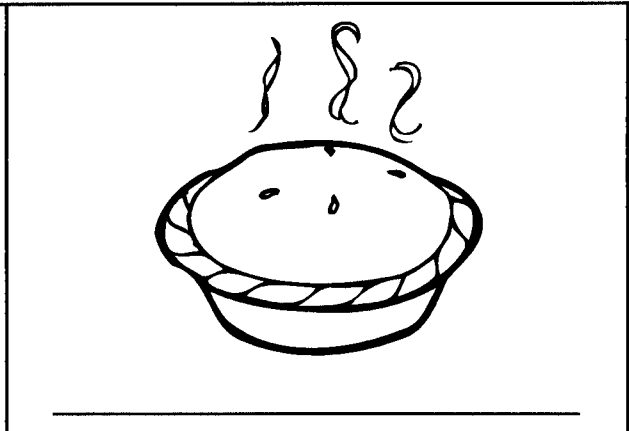
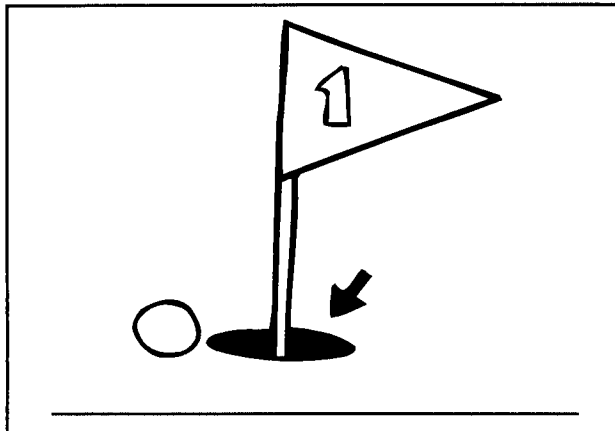
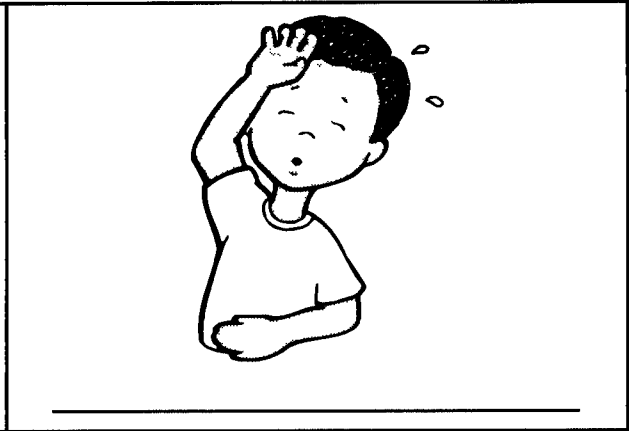
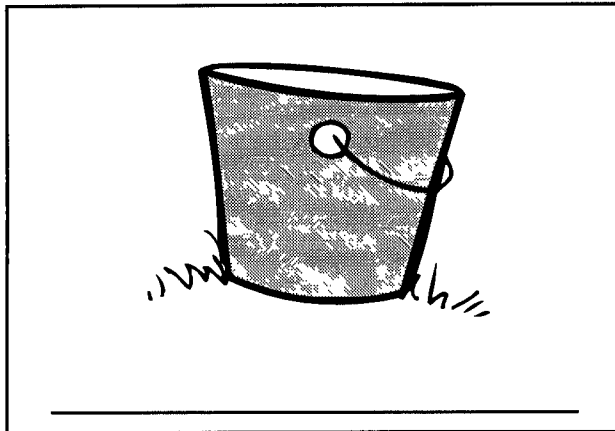

Homophones are two or more words that sound alike but are spelled differently and have different meanings.

Name _____ Date _____

Which Homophone Is It?

Instructions – Which one is it? Circle the correct homophone for each sentence.

1. This is equal to the sum of its parts.
Answer: the whole, the hole
2. Fish in the fishbowl will do this if you don't feed them.
Answer: die, dye
3. You need this to write with.
Answer: led, lead
4. If you get a prize, that means you have done this.
Answer: one, won
5. Two of gloves or socks or shoes are called this.
Answer: a pair, a pear
6. If you have very light skin, people may say you have this.
Answer: pail skin, pale skin
7. You can call this the ocean or you can call this another name.
Answer: the see, the sea
8. Dogs and cats have these, but people don't.
Answer: pause, paws
9. This is a unit of time.
Answer: our, hour
10. When you hit a surface very hard, you can make these.
Answer: dense, dents
11. We can do this to cheese, potatoes or carrots if we want to make shredded pieces.
Answer: great, grate
12. A place where something can be found.
Answer: their, there

Homophones are two or more words that sound alike but are spelled differently and have different meanings.

Name _____ Date _____

Correction Time

Instructions – Some of the homophones in the sentences below are correct, and some are wrong. If the homophone is correct, leave the sentence alone. If the homophone is wrong, cross it out and write the correct word above the wrong one.

1. The **hole** class applauded when the teacher said there would be no test today.
2. Our team **led** the other team by ten points.
3. I **one** the game, but I still had to do the dishes.
4. I can't wait to wear my new **pear** of boots in the snow.
5. We found our kitten asleep in the **pail**.
6. I couldn't **see** my mistake even when the teacher pointed it out.
7. My dog's **pause** were all muddy when he came in from the rain.
8. Our new hall clock chimes every half **our**.
9. I counted twelve **dense** in the fender.
10. I won a **great** big panda at the fair.
11. I wondered why **their** wasn't any cake left after the party.
12. We couldn't swim in the **see** today; the water was too rough.
13. The **whole** in my sweater was getting bigger each day.
14. I was afraid my fish would **dye** if we let my sister take care of them.
15. The guide **lead** us back to the front of the museum.
16. The speaker decided to **paws** in the middle of his speech to answer questions from the crowd.
17. The **pair** looked overripe so I threw it away.
18. I wanted my room painted a **pale** blue shade.
19. That's a **grate** story you told, but I don't believe you.
20. I'm the only **won** in my class whose name begins with "Z".

Homophones are two or more words that sound alike but are spelled differently and have different meanings.

Name _____ Date _____

Hidden Homophone

Instructions – In each of the following sentences there is a “hidden homophone.” Find this “hidden homophone,” underline it, and write it as you found it in the blank next to the scrambled word in the parenthesis.

1. It was my turn to deal the cards in the game.

(lead) _____

2. My mother says I have to clean my room now.

(won) _____

3. When I was in third grade, my favorite game was leap frog.

(pale) _____

4. My flashlight needs a new battery often.

(dense) _____

5. My little brother wanted to swap his tricycle for a yo-yo.

(paws) _____

Homophones are two or more words that sound alike but are spelled differently and have different meanings.

Name _____ Date _____

Make Your Own Homophone

Instructions – In the boxes below, draw a picture of your favorite homophone pairs. Write the name of each homophone under each picture.

--	--

--	--

Homophones are two or more words that sound alike but are spelled differently and have different meanings.

Name _____ Date _____

Homophone Crossword Puzzle

Instructions – Have fun filling in the crossword puzzle. Each of the answers is a homophone. You may choose your answers from the word list below.

whole - hole
dye - die
lead - led

one - won
pair - pear
pail - pale

sea - see
pause - paws
hour - our

dense - dents
grate - great
their - there

Across

1. A pronoun
4. To stop for a while
6. Opposite of followed
8. Deep impressions made on hard surfaces
9. Two of these are this
11. Where it is located
12. A cavity
13. A thick fog is this

Down

2. To no longer exist
3. Entire or all
4. Very light in shade or color
5. An ocean
7. To tint
9. An animal has four
10. Very big or wonderful
12. Unit of time
14. To look

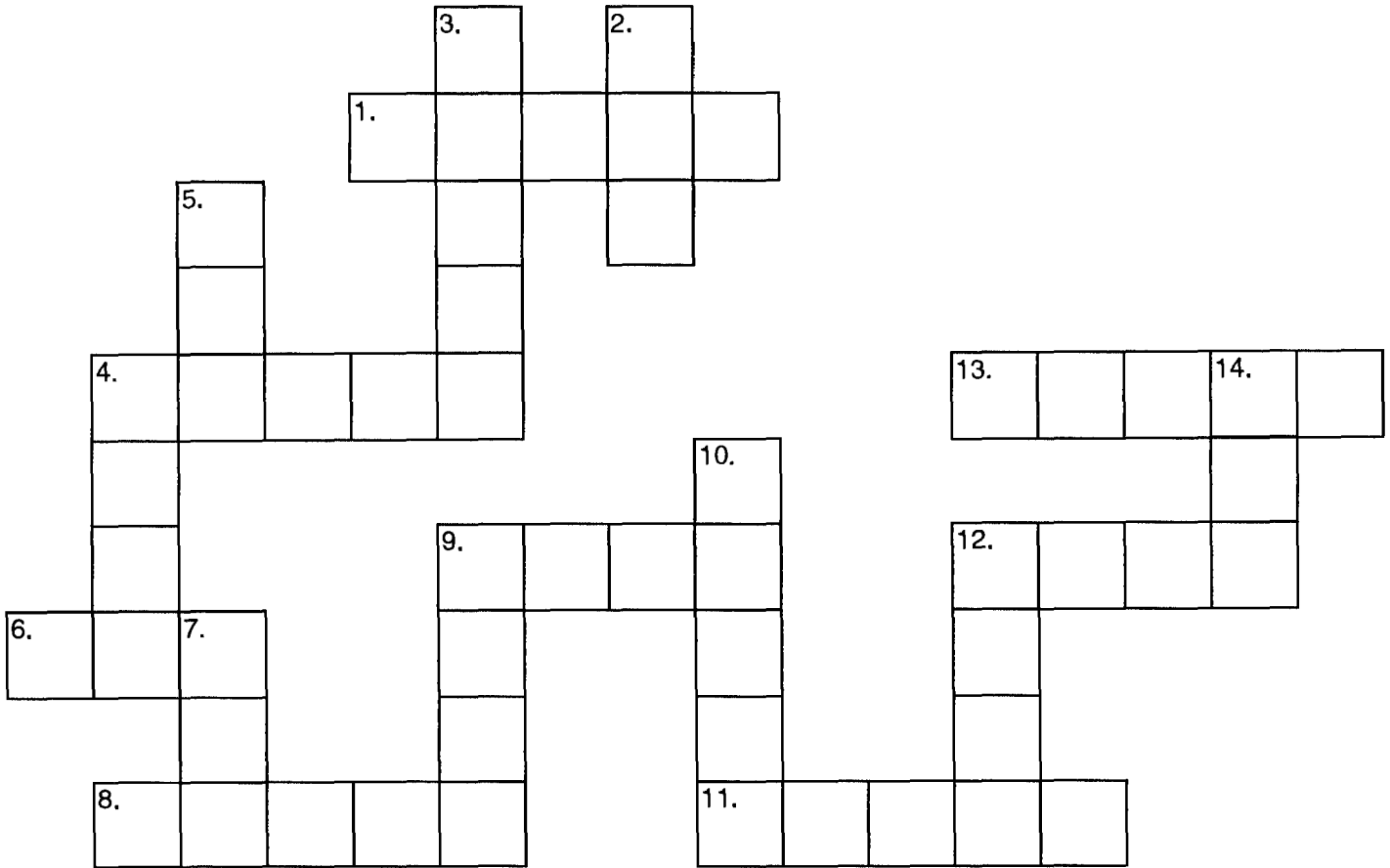

Homophones are two or more words that sound alike but are spelled differently and have different meanings.

Name _____ Date _____

Homographs

Homographs are words which are spelled alike but have two different meanings.

Instructions – The homographs listed below have two and sometimes three meanings. Yet, it is possible that some of the homographs can have even more meanings than those given in this lesson.

- | | |
|------------|-----------|
| 1. pool | 7. top |
| 2. school | 8. batter |
| 3. ruler | 9. pit |
| 4. pitcher | 10. scale |
| 5. block | 11. star |
| 6. chest | 12. bat |

Correct the Homograph

Instructions – Fill in each blank in the sentences below with the correct homograph. Choose from the homograph list below. Remember to use each word in two and sometimes three sentences.

pool

school

ruler

pitcher

block

chest

top

batter

pit

scale

star

bat

1. In the summer, we have fun swimming in my neighbor's _____.
2. The _____ was filled with ice-cold lemonade.
3. My cousin is an actress in Hollywood and wants to be a big _____ one day.
4. My mom always put a little nutmeg into the pancake _____.
5. The ball rolled into a _____ and we couldn't get it out.
6. We gave the baby a blue and red _____, and it's now his favorite toy.
7. In the fairytale, the _____ of the kingdom was a wise, old gnome.
8. Under the water, we saw a _____ of silver fish swimming quickly away from us.
9. I was coughing so much, my _____ was beginning to hurt.
10. Tomorrow I am going to my new _____.
11. Every time I see the first _____ in the sky, I make a wish.
12. I watched the cook remove every _____ on the fish before he baked it in the oven.

Homographs are words which are spelled alike but have different meanings.

Name _____ Date _____

Correct the Homograph

Continued

13. My friend let me borrow his brand new _____ for the baseball game.
14. My older brother taught me how to shoot _____.
15. My uncle said he always wanted to be a _____ for a major league baseball team.
16. I needed a _____ to underline the words in my sentences.
17. I weighed myself on the _____ in the nurse's office.
18. We had a contest to see who could get to the _____ of hill the fastest.
19. When my mom was in elementary school, she said she walked to school because it was just down the _____.
20. My cat, Dinah, was having fun playing with a peach _____.
21. The pirate buried his treasure _____ deep in the ground.
22. My baby sister likes to pile one _____ on top of another.
23. I didn't follow my friends into the cave because I was afraid a _____ would fly on my head.
24. The music teacher made us sing up and down the _____ ten times.
25. Our mothers formed a car _____ to take us to school each morning.
26. The _____ hit a home run out of the ball park.

Homographs are words which are spelled alike but have different meanings.

Name _____ Date _____

Name The Homographs

Instructions – Look at each set of pictures below. Choose the correct homographs for each set from the word list, and write it in the spaces provided.

top
batter

bat
pitcher

pool
chest

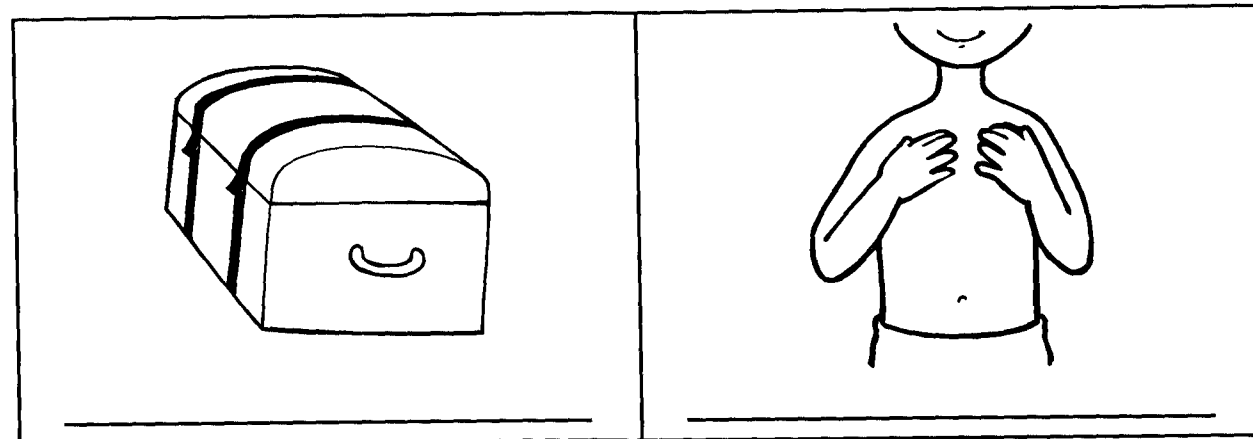
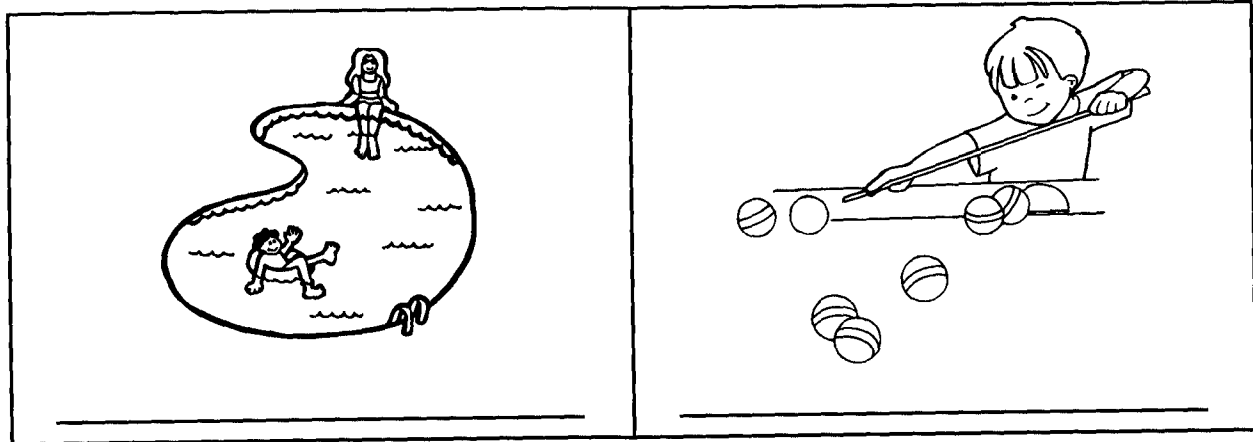
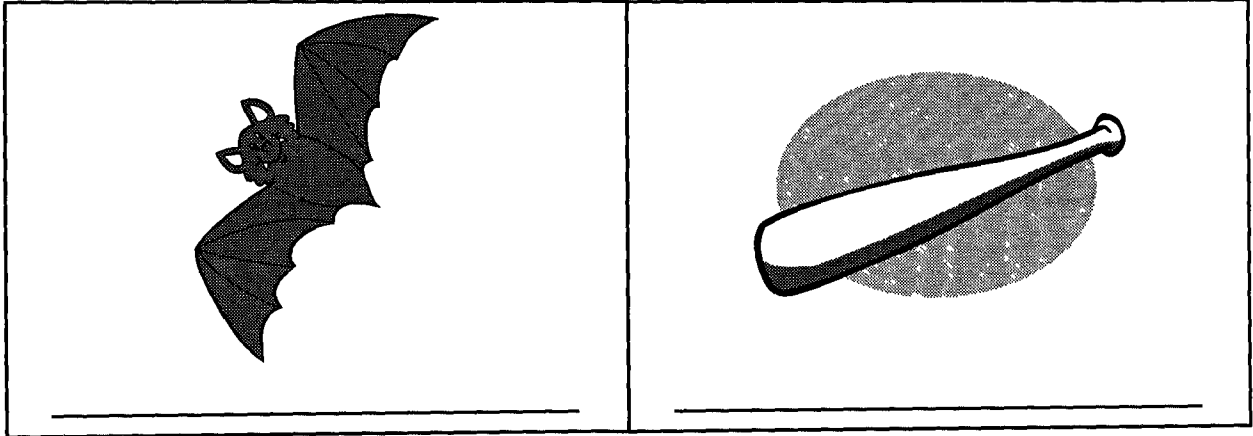

Homographs are words which are spelled alike but have different meanings.

Name _____ Date _____

Name The Homographs

Instructions – Look at each set of pictures below. Choose the correct homographs for each set from the word list, and write it in the spaces provided.

top
batter

bat
pitcher

pool
chest

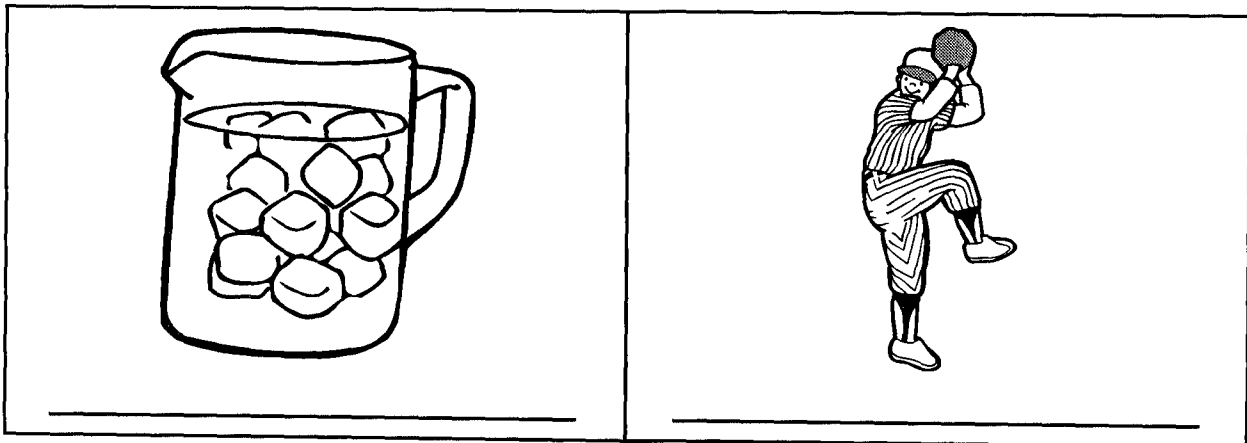
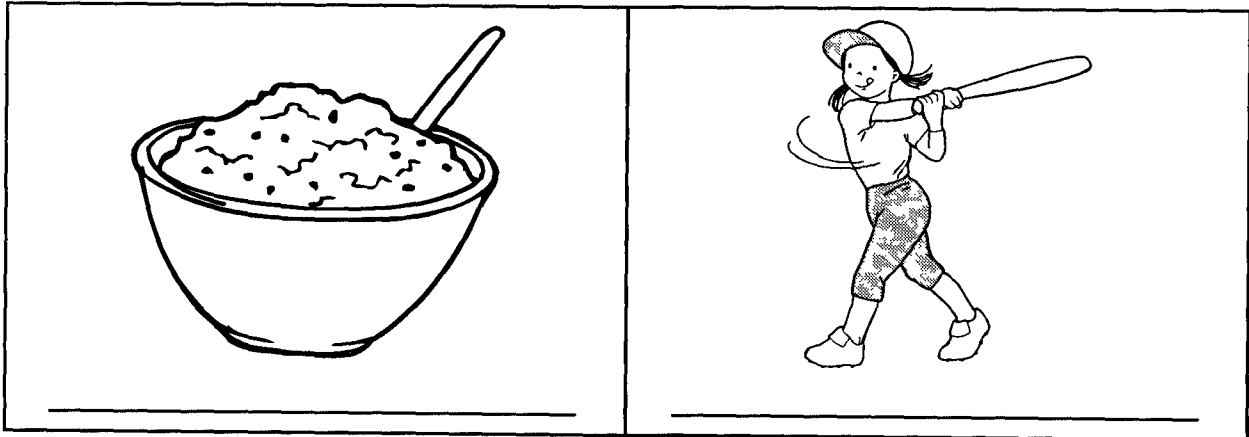
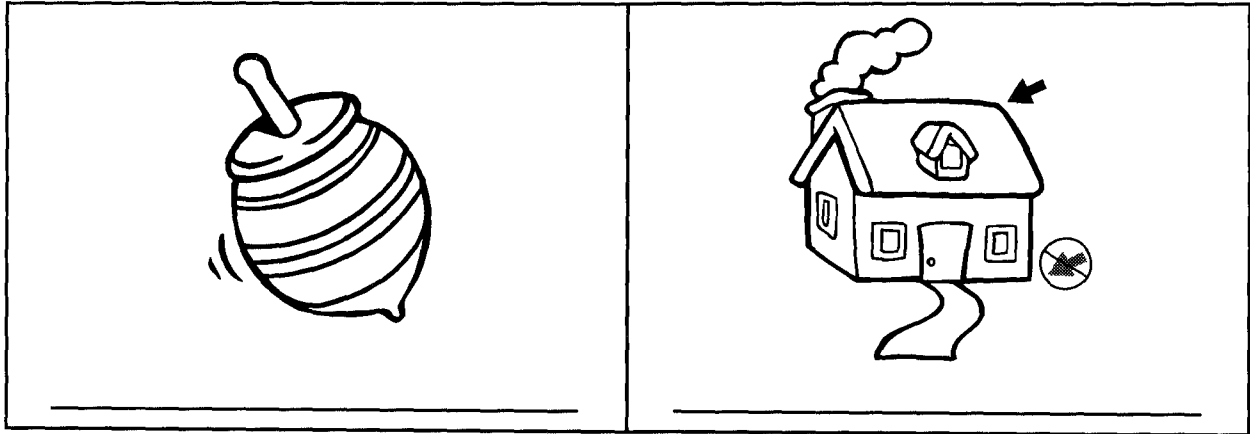

Homographs are words which are spelled alike but have different meanings.

Name _____ Date _____

Homograph Answers

Instructions – Write the correct homograph next to its meaning in the following. Choose each homograph from those listed below.

pool	pitcher	top	scale
school	block	batter	star
ruler	chest	pit	bat

1. A measuring stick: _____
2. A toy a child can build things with: _____
3. A place where you go to learn: _____
4. A part of your upper body: _____
5. A person who throws the ball to a batter: _____
6. A child's toy that can spin: _____
7. A hard seed in a fruit: _____
8. A thick, beaten mixture of flour, milk and eggs: _____
9. A part of a fish: _____
10. A mammal that flies at night: _____
11. A small body of water for swimming: _____
12. Someone who has a leading role in a movie: _____

Homographs are words which are spelled alike but have different meanings.

Name _____ Date _____

Homograph Sentences

Instructions – Choose any six homographs from the homograph list below. Then, write two sentences for each homograph. Remember to use a different meaning in each sentence. Underline the homograph in each sentence.

pool
school
ruler

pitcher
block
chest

top
batter
pit

scale
star
bat

1. _____
2. _____
3. _____
4. _____
5. _____
6. _____
7. _____
8. _____
9. _____
10. _____
11. _____
12. _____

Homographs are words which are spelled alike but have different meanings.

Name _____ Date _____

Homograph Sentence Scramble

Instructions – Unscramble these sentences. Write the correct sentences in the blanks under the scrambled sentences. Circle the homograph. Use the word list below for help.

pool

pitcher

top

scale

school

block

batter

star

ruler

chest

pit

bat

1. The dog block I walked around my.

2. To be in my class star I wanted a play.

3. At Earth is a star only seen from night.

4. The top of the mountain covered the snow.

5. In my garden the soil in the pit avocado I planted.

Homographs are words which are spelled alike but have different meanings.

Name _____ Date _____

Make Your Own Homograph

Instructions – In the boxes below, draw a picture of your favorite homographs. Write the name of each homograph under each picture.

--	--

--	--

Homographs are words which are spelled alike but have different meanings.

Name _____ Date _____

Homograph Crossword Puzzle

Instructions – Have fun filling in the crossword puzzle. Each of the answers is a homograph. You may choose your answers from the word list below.

pool
school
ruler

pitcher
block
chest

top
batter
pit

scale
star
bat

Across

1. A street where you live
4. A baseball player
7. To share a ride in a car with a group of people
8. Notes of music
9. A deep hole
10. A bright, shining object in the sky

Down

2. A person who governs
3. A part of your upper body
4. A wooden club
5. A child's toy that spins
6. A large group of fish swimming together
9. A container that holds cold drinks

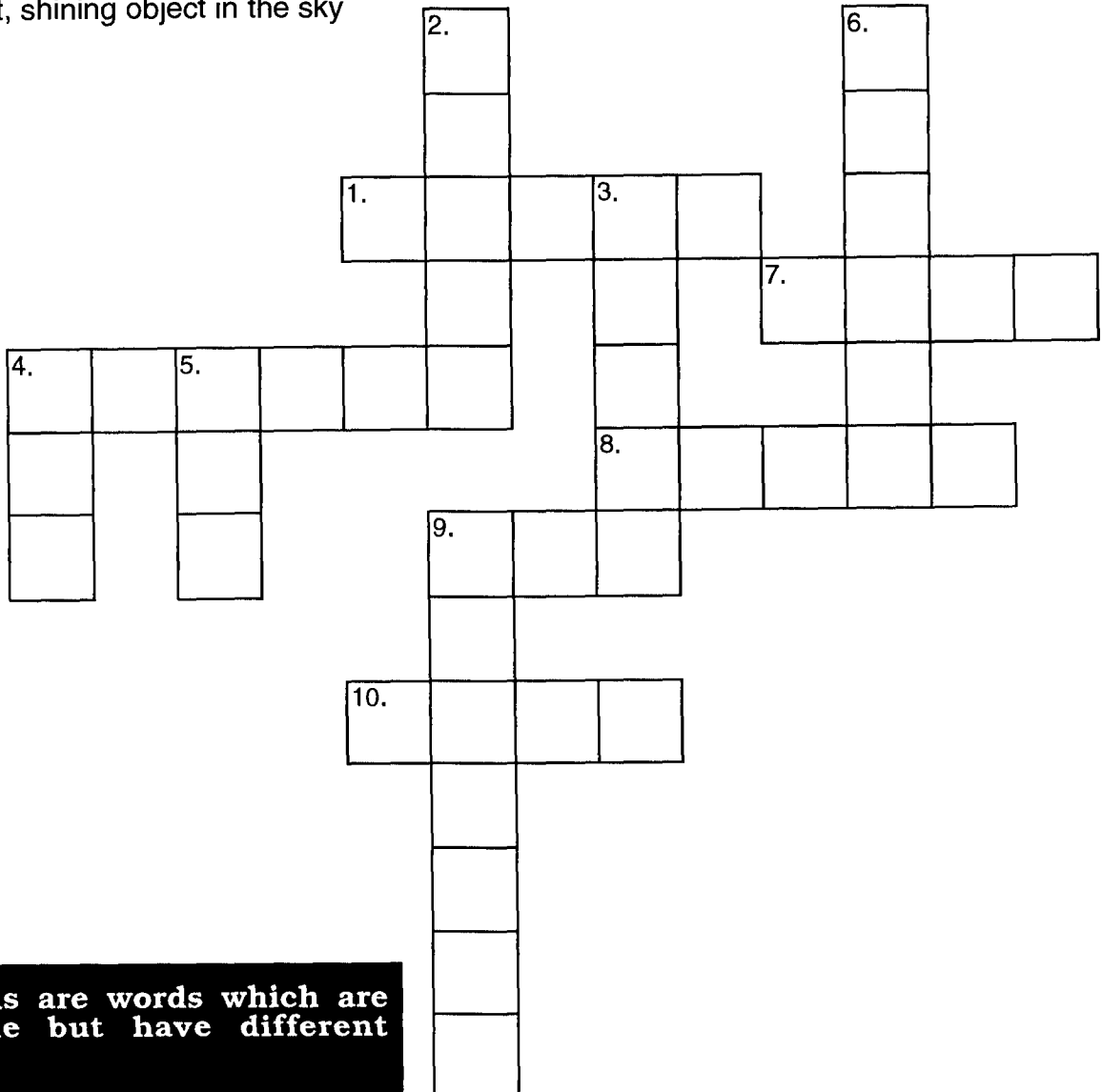

Homographs are words which are spelled alike but have different meanings.

Name _____ Date _____

Homographs

Homographs are words which are spelled alike but have two different meanings.

Instructions – The homographs listed below have two and sometimes three meanings. Yet, it is possible that some of the homographs can have even more meanings than those given in this lesson.

- | | |
|---------|------------|
| 1. cast | 7. diamond |
| 2. back | 8. foot |
| 3. part | 9. pupil |
| 4. pen | 10. nail |
| 5. pipe | 11. tip |
| 6. sole | 12. club |

Correct the Homograph

Instructions – Fill in each blank in the sentences below with the correct homograph. Choose from the homograph list below. Remember to use each word in two and sometimes three sentences.

cast

pen

diamond

nail

back

pipe

foot

tip

part

sole

pupil

club

1. We started a new _____ and were going to meet for the first time today.
2. After I broke my leg, I had to wear a _____ for months.
3. My mother likes the smell of my father's _____ tobacco.
4. The _____ of my left shoe had a big hole in it.
5. We saw the pigs playing in their pig _____.
6. "Let me give you a _____," my mom said, "Don't stay up so late next time!"
7. My aunt proudly showed us her new _____ ring.
8. I tried to hammer the _____ in the wall, but I dropped it.
9. The giant hot dog was a _____ long.
10. I cut the _____ of my finger on a piece of paper.
11. I was the only _____ in my class who got 100% on the test.
12. I wanted a _____ in the play, but I was too shy to say so.

Homographs are words which are spelled alike but have different meanings.

Name _____ Date _____

Correct the Homograph

Continued

13. I sat in _____ of the room, and I couldn't hear the speaker.
14. Lemon _____ is my favorite kind of fish to eat.
15. When a big water _____ broke, we had no water for days.
16. My ballpoint _____ ran out of ink.
17. A policeman carries a _____ as well as a gun.
18. I always get confused over a spade or a _____ in a card game.
19. My dad gave the waiter a big _____ because he was so nice.
20. The _____ consisted of just six people.
21. I hurt my _____ and I didn't want to participate in exercises.
22. I shut the door on my thumb _____ and it turned black and blue.
23. I only ate a _____ of the meal; I saved my appetite for dessert.
24. This was the first time I saw a baseball _____ in a real ball park.
25. I kept quiet even when my dance partner stepped on my _____.
26. The doctor checked the _____ of my eye.

Homographs are words which are spelled alike but have different meanings.

Name _____ Date _____

Name The Homographs

Instructions – Look at each set of pictures below. Choose the correct homographs for each set from the word list, and write it in the spaces provided.

foot
diamond

cast
pipe

pen
back

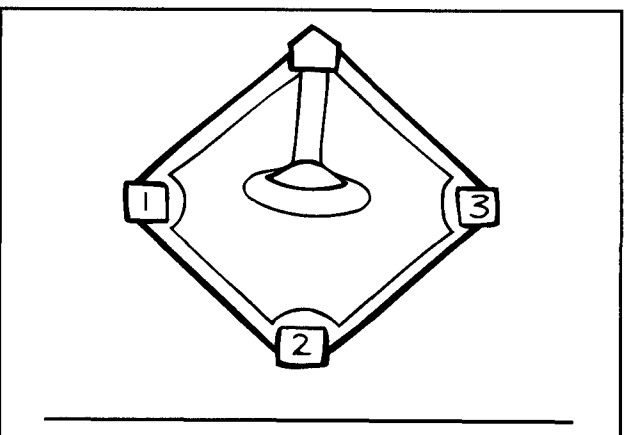
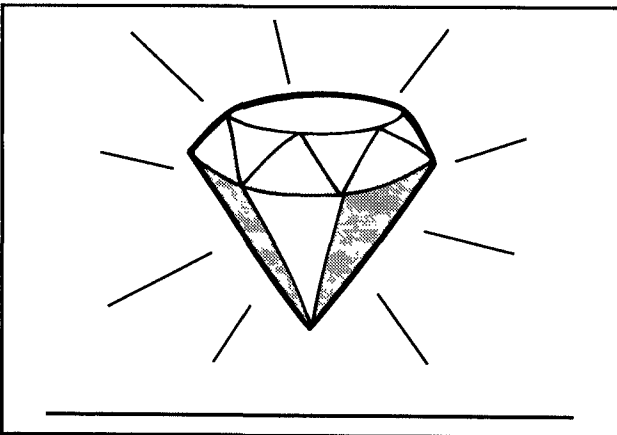
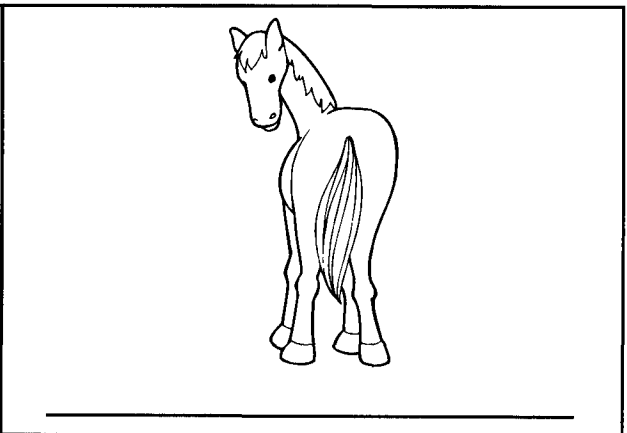
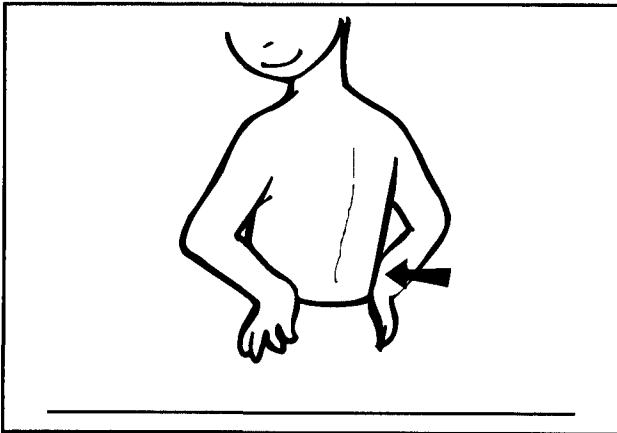
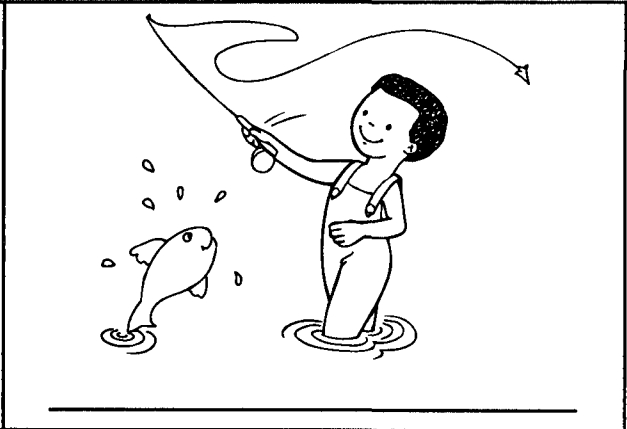
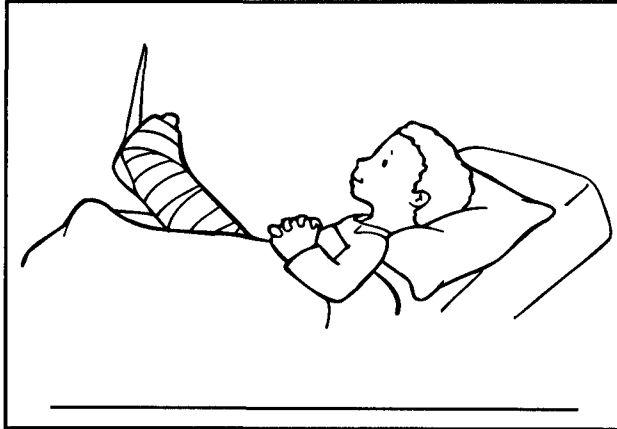

Homographs are words which are spelled alike but have different meanings.

Name _____ Date _____

Name The Homographs

Instructions – Look at each set of pictures below. Choose the correct homographs for each set from the word list, and write it in the spaces provided.

foot
diamond

cast
pipe

pen
back

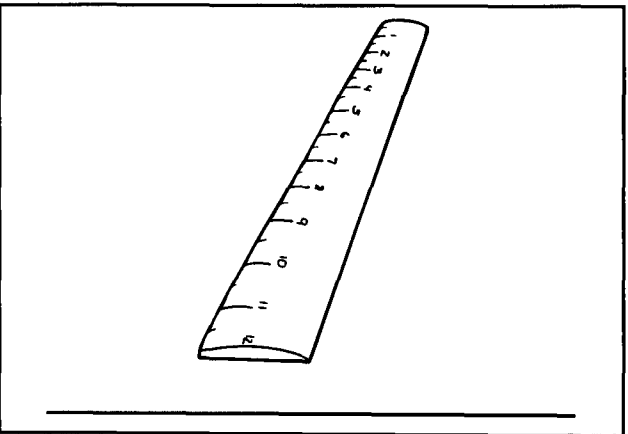
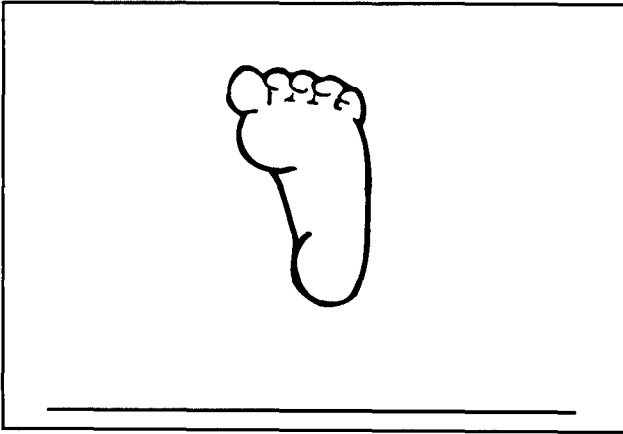
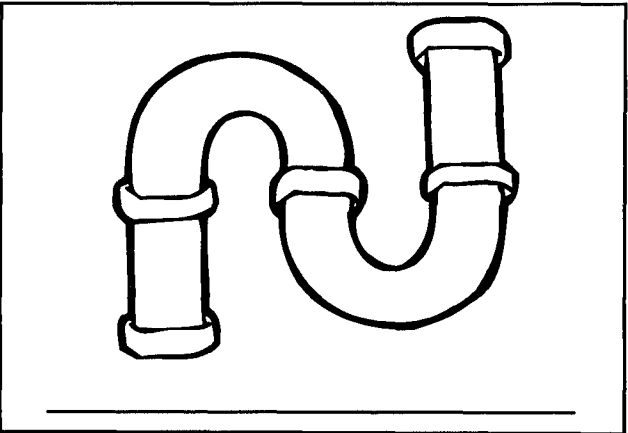
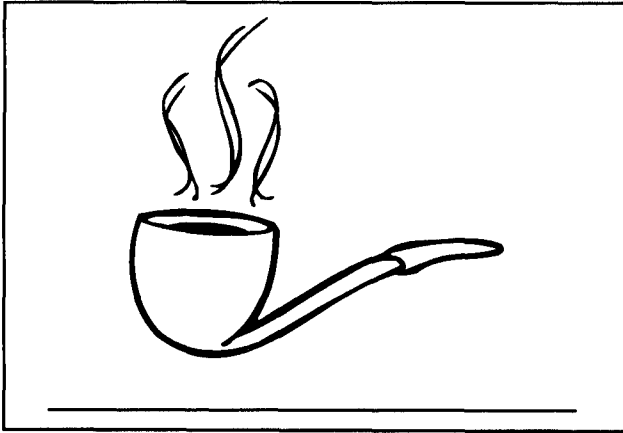
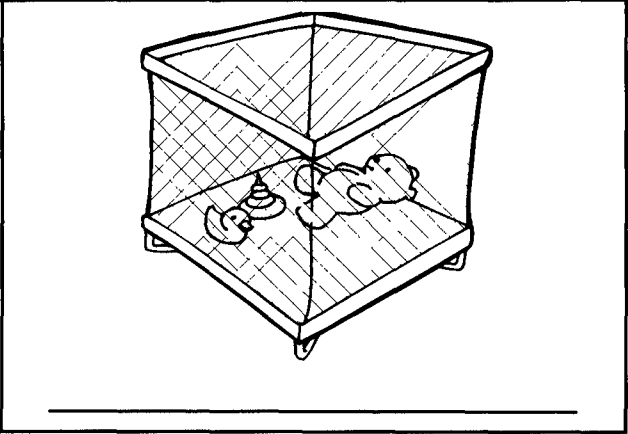
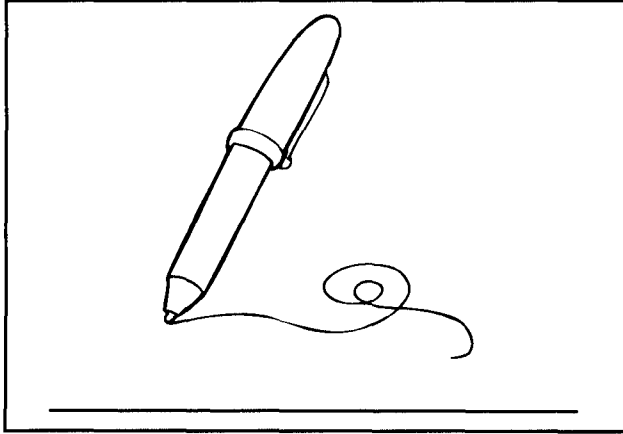

Homographs are words which are spelled alike but have different meanings.

Name _____ Date _____

Homograph Answers

Instructions – Write the correct homograph next to its meaning in the following. Choose each homograph from those listed below.

cast

pen

diamond

nail

back

pipe

foot

tip

part

sole

pupil

club

1. A hollow tube which carries fluid or gas: _____
2. A fenced place for animals to stay: _____
3. The bottom part of your shoe: _____
4. The opposite of front: _____
5. A precious gem: _____
6. A piece of something: _____
7. All the people that act in a certain play: _____
8. Twelve inches equal this: _____
9. A part of your finger: _____
10. A helpful hint: _____
11. A group of people who join together for a common purpose:

12. The black part in the center of the eye: _____

Homographs are words which are spelled alike but have different meanings.

Name _____ Date _____

Homograph Sentences

Instructions – Choose any six homographs from the homograph list below. Then, write two sentences for each homograph. Remember to use a different meaning in each sentence. Underline the homograph in each sentence.

cast
back
part

pen
pipe
sole

diamond
foot
pupil

nail
tip
club

1. _____

2. _____

3. _____

4. _____

5. _____

6. _____

7. _____

8. _____

9. _____

10. _____

11. _____

12. _____

Homographs are words which are spelled alike but have different meanings.

Name _____ Date _____

Homograph Sentence Scramble

Instructions – Unscramble these sentences. Write the correct sentences in the blanks under the scrambled sentences. Circle the homograph. Use the word list below for help.

cast

pen

diamond

nail

back

pipe

foot

tip

part

sole

pupil

club

1. A party had after the cast the play.

2. Because of the auditorium stood back I in the were there no seats.

3. My sister's baby foot and I stepped on she screamed by mistake.

4. A dad had his sore the foot of sole on.

5. Diamond on the baseball home base in back of sat I.

Homographs are words which are spelled alike but have different meanings.

Name _____ Date _____

Make Your Own Homograph

Instructions – In the boxes below, draw a picture of your favorite homographs. Write the name of each homograph under each picture.

--	--

--	--

Homographs are words which are spelled alike but have different meanings.

Name _____ Date _____

Homograph Crossword Puzzle

Instructions – Have fun filling in the crossword puzzle. Each of the answers is a homograph. You may choose your answers from the word list below.

cast
back
part

pen
pipe
sole

diamond
foot
pupil

nail
tip
club

Across

1. Baseball infield
3. A student
6. Bottom of your foot
8. Part of your body
10. Piece
11. It has five toes

Down

2. Part of a finger
3. A writing tool
4. You put tobacco in it
5. The members of a play
7. A card symbol
9. Money you give for good service

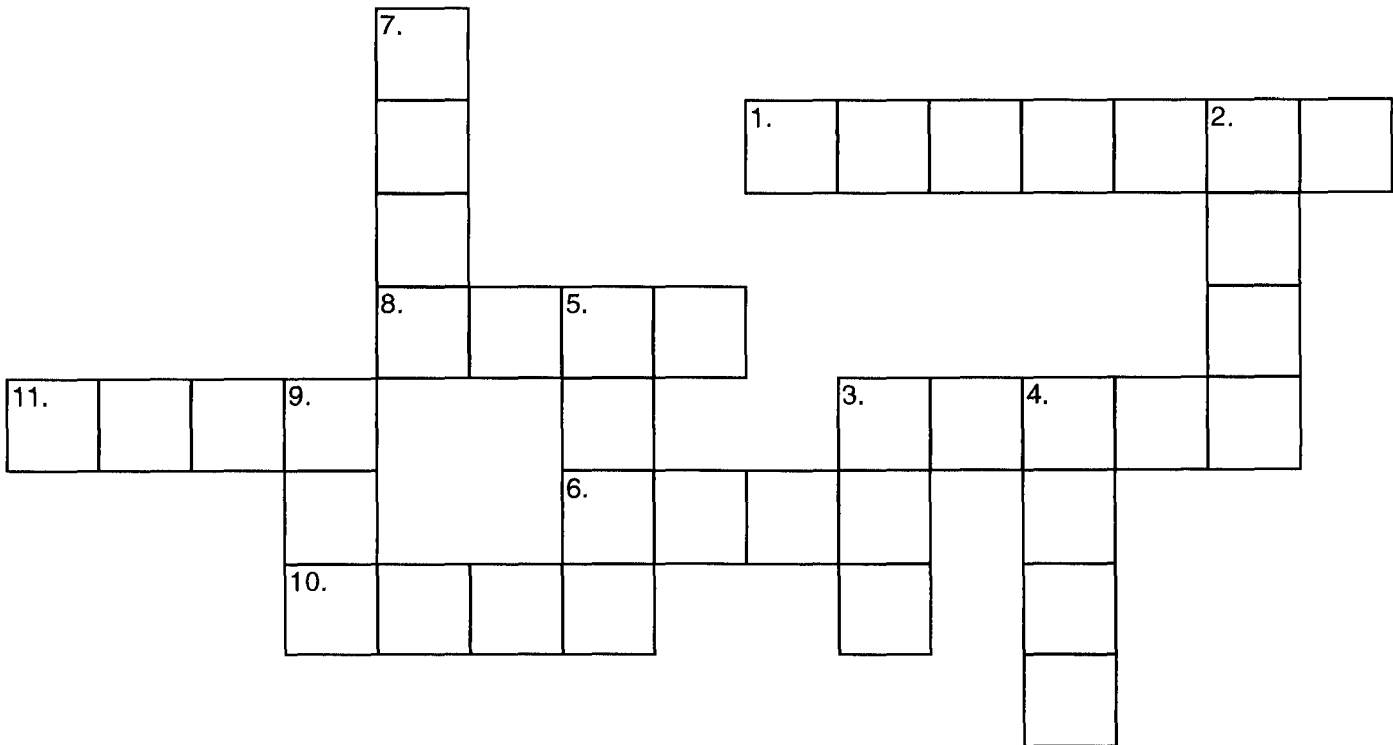

Homographs are words which are spelled alike but have different meanings.

Name _____ Date _____

Homographs

Homographs are words which are spelled alike but have two different meanings.

Instructions – The homographs listed below have two and sometimes three meanings. Yet, it is possible that some of the homographs can have even more meanings than those given in this lesson.

1. page

2. seal

3. teeth

4. story

5. ring

6. switch

7. yard

8. pound

9. file

10. bill

11. tape

12. ball

Correct the Homograph

Instructions – Fill in each blank in the sentences below with the correct homograph. Choose from the homograph list below. Remember to use each word in two and sometimes three sentences.

page
seal
teeth

story
ring
switch

yard
pound
file

bill
tape
ball

1. My mom likes to use a different Christmas _____ on each card she sends to a friend during the holiday season.
2. Since my friend lives on the second _____ of his building, he uses the stairs instead of the elevator.
3. My father ordered a 1 $\frac{1}{2}$ _____ lobster for dinner.
4. You have to _____ the doorbell a few times before my grandfather answers the door.
5. The hallway was so dark you had to _____ on the light even in the daytime.
6. When the big dog showed his _____ and growled, we ran away fast.
7. My mother says you should _____ the veal first before you cook it.
8. My aunt keeps her Great Danes chained in her _____ every day.
9. My father has a _____ cabinet in his home office where he keeps all his important papers.
10. My baby brother tries to turn the _____ of the book before I finish reading it to him.
11. The restaurant _____ was so high, my father had to borrow money from my mom.
12. My teacher wants me to buy a notebook with a _____ binding rather than a spiral binding.

Homographs are words which are spelled alike but have different meanings.

Name _____ Date _____

Correct the Homograph

Continued

13. I still have the red, silver and blue _____ I had as a toddler.
14. We had to bring the lost dog to the _____, but we would take him home if no one claimed him in a few days.
15. When we were sitting in the hotel lobby, a _____ brought my dad a message.
16. I was surprised when I heard the principal _____ my brother to come down to his office.
17. Even though a _____ swims in the water like a fish, it is still a mammal.
18. "Be careful with that saw," my father said, "The _____ are very sharp."
19. When I was little, my favorite _____ was "The Wizard of Oz."
20. My mother bought a _____ of ribbon to make my sister's costume for Halloween.
21. I always wear my lucky _____ when I take a test in school.
22. My mother likes to _____ my father's nails every now and then.
23. The tropical bird had a beautiful yellow _____.
24. My sister is excited about going to a formal _____ at her college.
25. I wanted to _____ my vote to "no" when the class was polled, but it was too late.
26. Our teacher played a _____ of the concert for us.

Homographs are words which are spelled alike but have different meanings.

Name _____ Date _____

Name The Homographs

Instructions – Look at each set of pictures below. Choose the correct homographs for each set from the word list, and write it in the spaces provided.

tape
teeth

page
switch

seal
yard

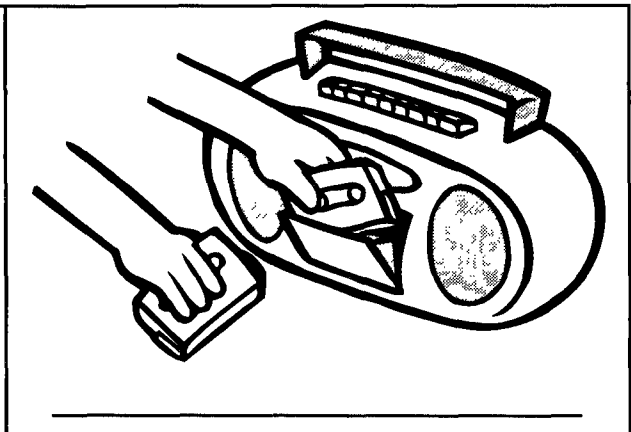
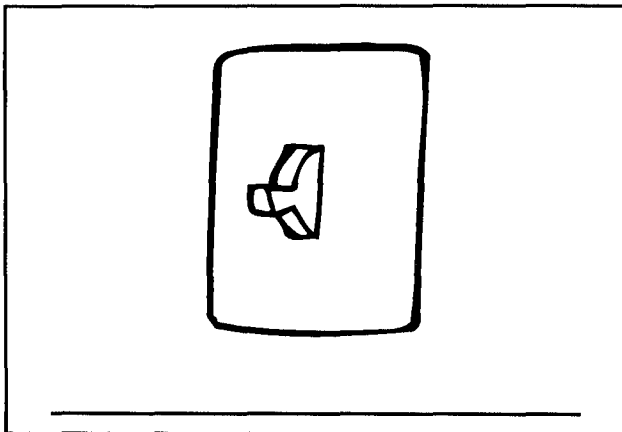
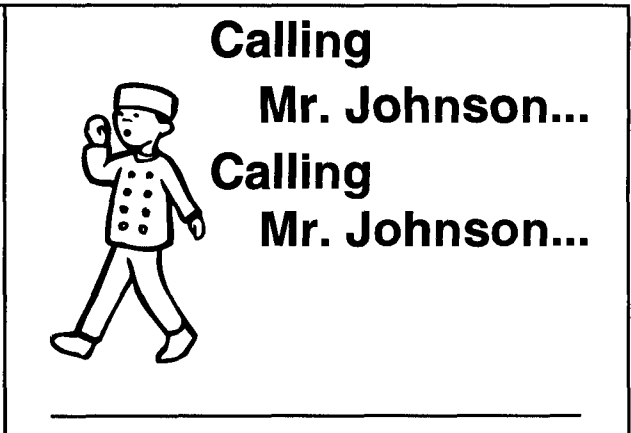
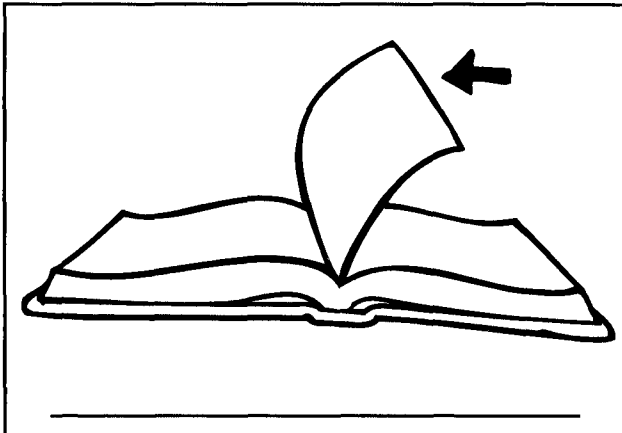
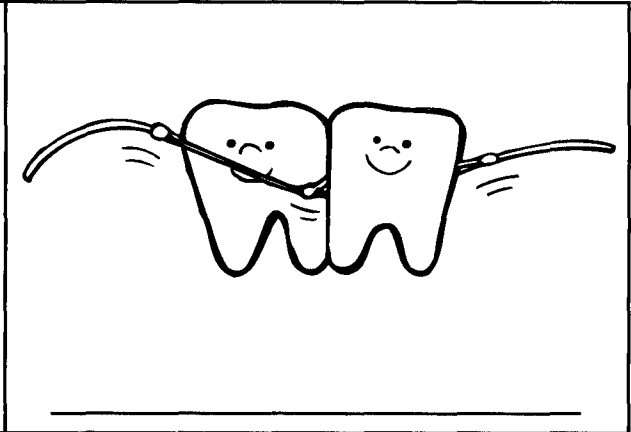
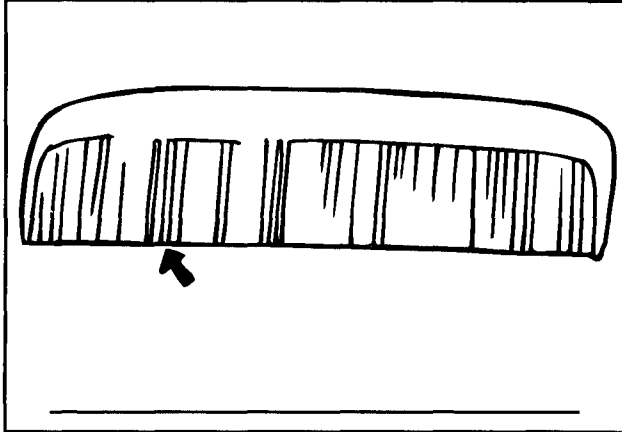

Homographs are words which are spelled alike but have different meanings.

Name _____ Date _____

Name The Homographs

Instructions – Look at each set of pictures below. Choose the correct homographs for each set from the word list, and write it in the spaces provided.

tape
teeth

page
switch

seal
yard

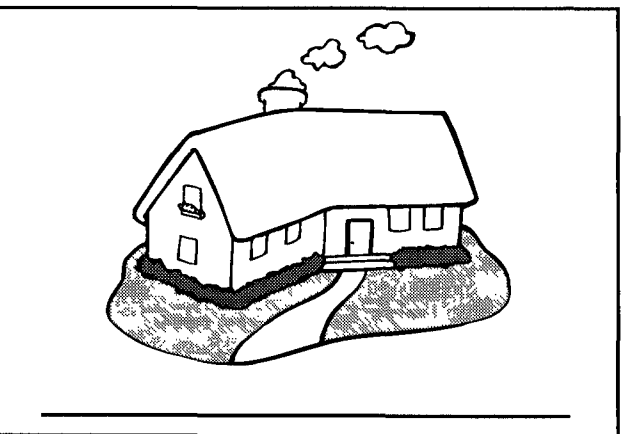
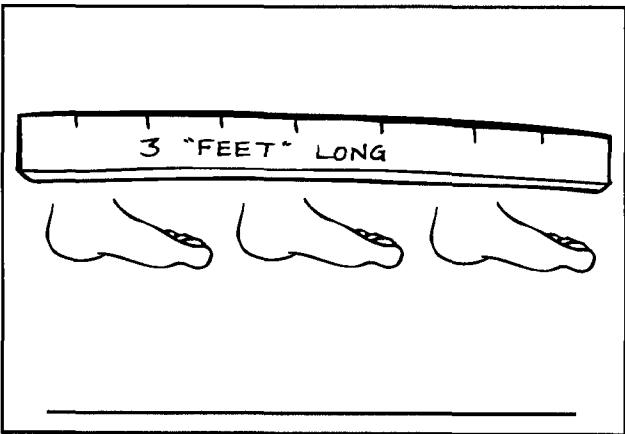
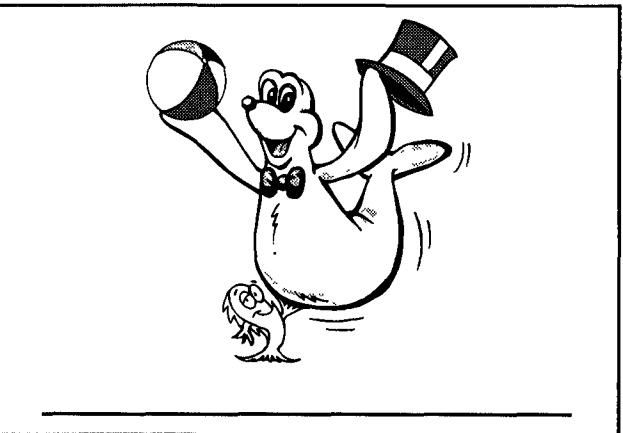
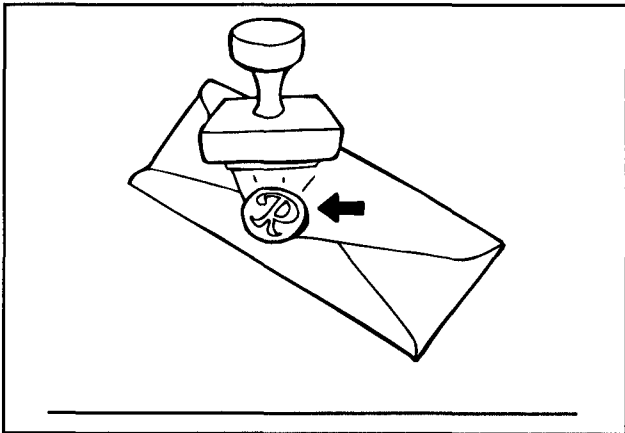
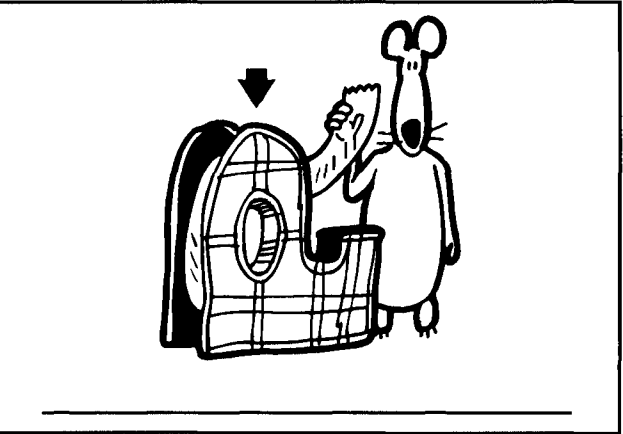
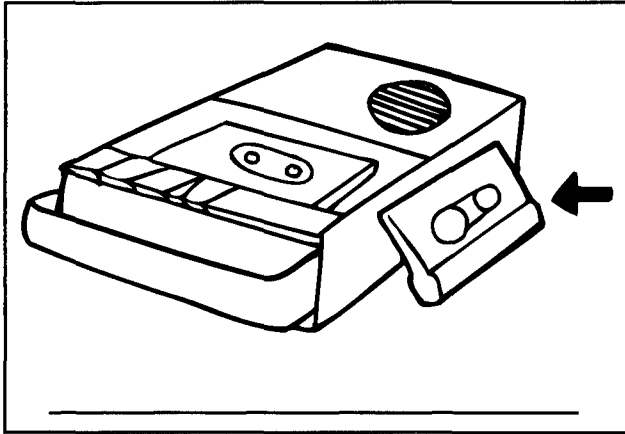

Homographs are words which are spelled alike but have different meanings.

Name _____ Date _____

Homograph Answers

Instructions – Write the correct homograph next to its meaning in the following. Choose each homograph from those listed below.

page
seal
teeth

story
ring
switch

yard
pound
file

bill
tape
ball

1. A unit of length equal to thirty-six inches: _____
2. A person who works in congress and carries messages: _____
3. A small disk of paper or wax stamped on an official document:

4. The bony structures in the jaw of your mouth: _____
5. A tale that you read or listen to: _____
6. A unit of weight equal to sixteen ounces: _____
7. A round, rubber toy that you bounce: _____
8. A piece of jewelry you wear on a finger: _____
9. To change your opinion or your attention: _____
10. A strip of material which you use to fasten one thing onto another
thing, such as a piece of paper: _____
11. A place where important papers are kept: _____
12. A statement of fees or charges that you owe: _____

Homographs are words which are spelled alike but have different meanings.

Name _____ Date _____

Homograph Sentences

Instructions – Choose any six homographs from the homograph list below. Then, write two sentences for each homograph. Remember to use a different meaning in each sentence. Underline the homograph in each sentence.

page
seal
teeth

story
ring
switch

yard
pound
file

bill
tape
ball

1. _____
2. _____
3. _____
4. _____
5. _____
6. _____
7. _____
8. _____
9. _____
10. _____
11. _____
12. _____

Homographs are words which are spelled alike but have different meanings.

Name _____ Date _____

Homograph Sentence Scramble

Instructions – Unscramble these sentences. Write the correct sentences in the blanks under the scrambled sentences. Circle the homograph. Use the word list below for help.

page

story

yard

bill

seal

ring

pound

tape

teeth

switch

file

ball

1. The circus at the seal we watched balance on a ball its nose.

2. A seat wanted to switch my sister her for window aisle seat.

3. Came to the bill one dollars hundred.

4. To ring for it you must the bell push hard.

5. All the pictures I wanted my scrapbook to tape into.

Homographs are words which are spelled alike but have different meanings.

Name _____ Date _____

Make Your Own Homograph

Instructions – In the boxes below, draw a picture of your favorite homographs. Write the name of each homograph under each picture.

--	--

--	--

Homographs are words which are spelled alike but have different meanings.

Name _____ Date _____

Homographs

Homographs are words which are spelled alike but have two different meanings.

Instructions – The homographs listed below have two and sometimes three meanings. Yet, it is possible that some of the homographs can have even more meanings than those given in this lesson.

1. quarter
2. letters
3. date
4. patient
5. plant
6. keys

7. palm
8. glasses
9. check
10. rare
11. line
12. head

Correct the Homograph

Instructions – Fill in each blank in the sentences below with the correct homograph. Choose from the homograph list below. Remember to use each word in two and sometimes three sentences.

quarter
letters
date

patient
plant
keys

palm
glasses
check

rare
line
head

1. I remember my dad was very _____ with me when he taught me to ride a two-wheeler bicycle.
2. I filled two _____ with lemonade and took them outside.
3. My friend said a bird once landed on his _____, but I didn't believe him.
4. The usher told us that the _____ formed to the right.
5. My grandfather likes to collect _____ stamps.
6. When my aunt lost the _____ to the car, she was grateful that she had a spare set in her house.
7. My art teacher taught me how to write the _____ in calligraphy.
8. My teacher said she would _____ our answers before the class was over.
9. It was a hot day so the candy melted in the _____ of my hand.
10. I had a _____ to meet my friend at the mall after school.
11. I used my last _____ to make a phone call.
12. My father always ordered his steak _____ at a restaurant.

Homographs are words which are spelled alike but have different meanings.

Name _____ Date _____

Correct the Homograph

Continued

13. My cat jumped up on the _____ of the piano.
14. My little sister had never seen a _____ tree before and was so excited the first time she saw one.
15. My neighbor is the _____ custodian in my school.
16. My father is not a good _____ when he gets sick; he doesn't like to stay in bed.
17. My uncle Ted works in an industrial _____.
18. I had never eaten a _____ before, but I liked it.
19. My mom said there was a _____ of the pie left in the refrigerator if I wanted it.
20. I drew a _____ down the center of the page and then through the middle of the page to make four sections.
21. My favorite house _____ is the philodendron.
22. I went to the eye doctor to see if I needed _____.
23. You should always purchase cake on or before the _____ stamped on the bottom of the cake box.
24. I kept the _____ from my friend, Kate, in a special box in my dresser.
25. My aunt and uncle gave me a _____ for \$50.00 for my birthday.
26. The _____ for the meal in the restaurant came to \$18.00 for the two of us.

Homographs are words which are spelled alike but have different meanings.

Name _____ Date _____

Name The Homographs

Instructions – Look at each set of pictures below. Choose the correct homographs for each set from the word list, and write it in the spaces provided.

glasses
check

letters
palm

plant
keys

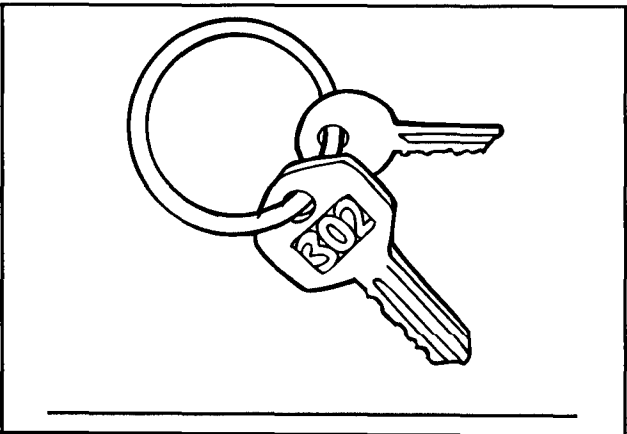
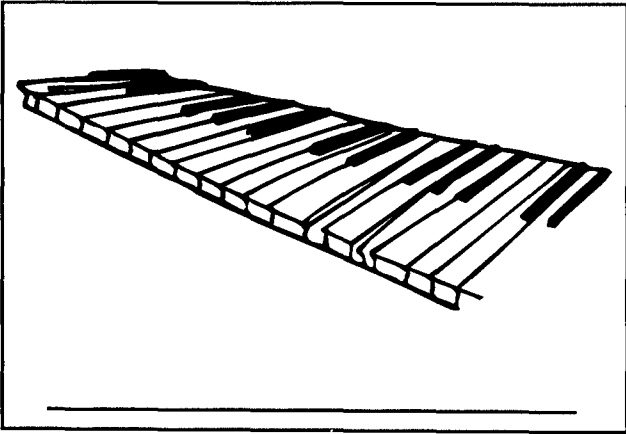
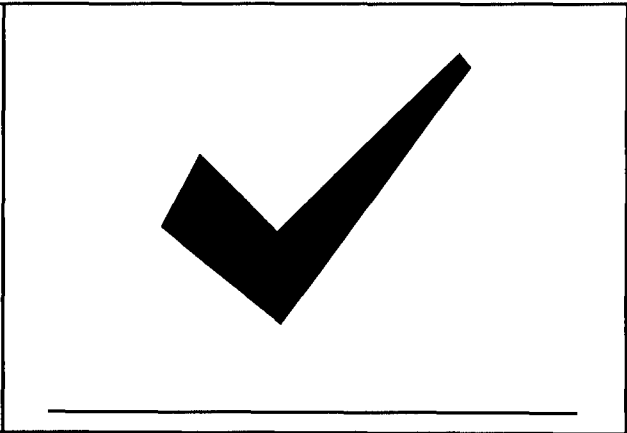
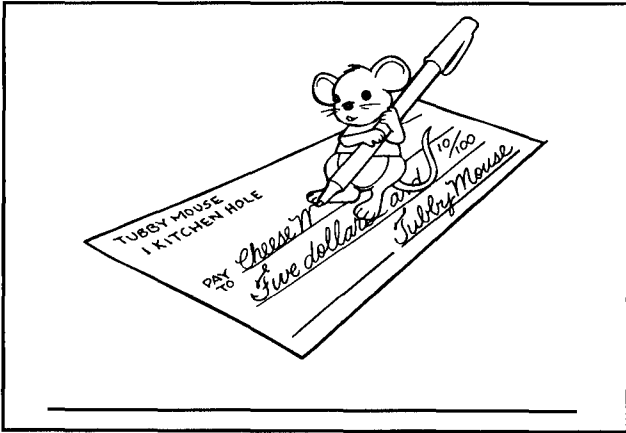
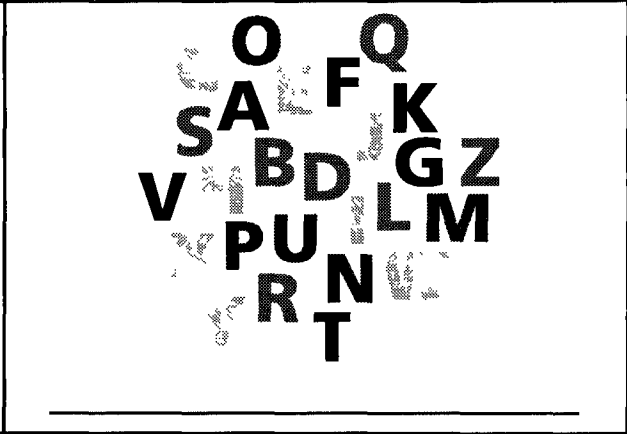
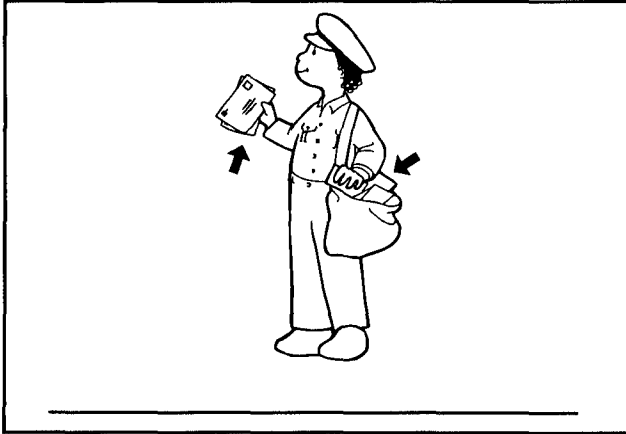

Homographs are words which are spelled alike but have different meanings.

Name _____ Date _____

Name The Homographs

Instructions – Look at each set of pictures below. Choose the correct homographs for each set from the word list, and write it in the spaces provided.

glasses
check

letters
palm

plant
keys

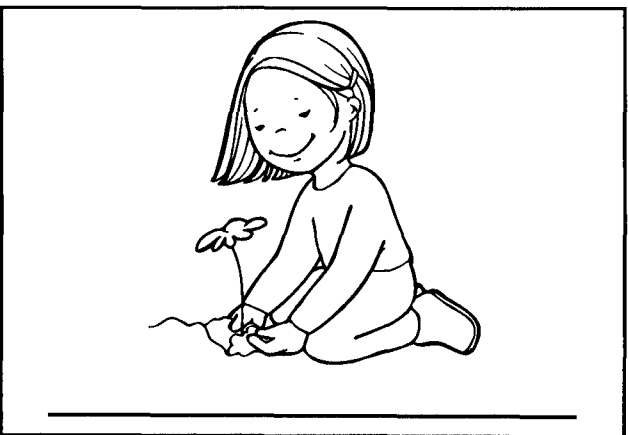
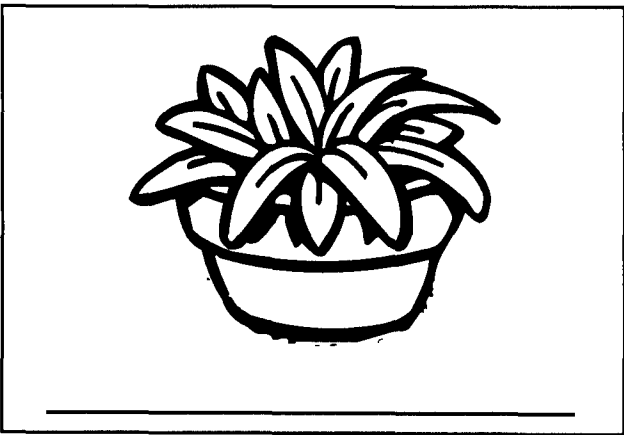
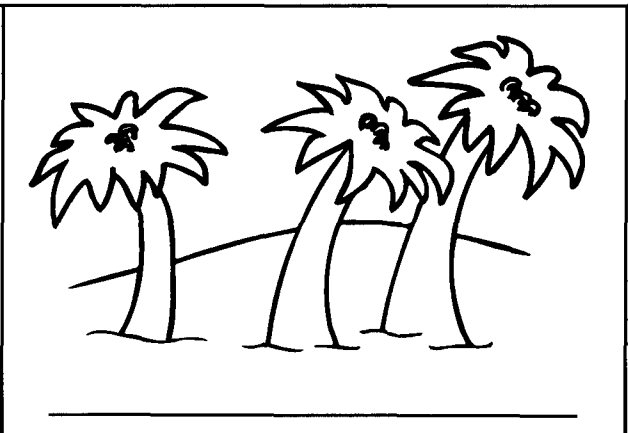
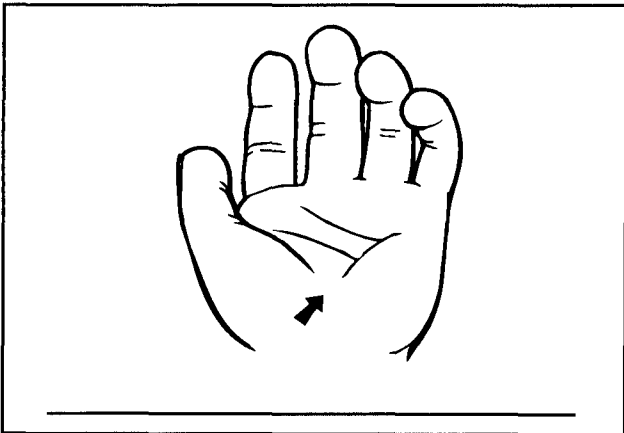
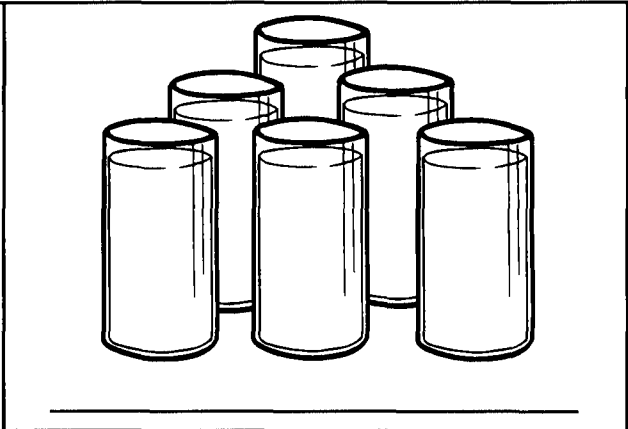
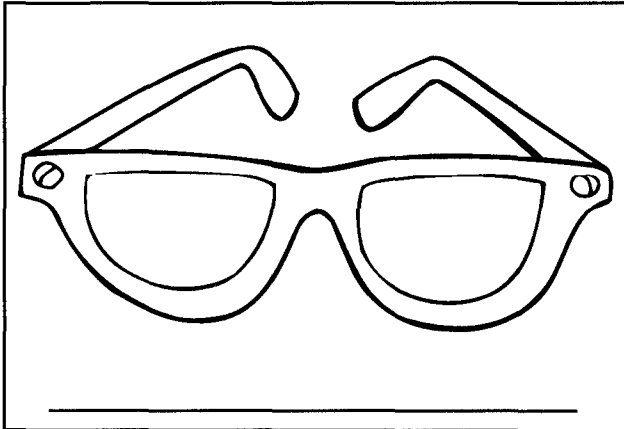

Homographs are words which are spelled alike but have different meanings.

Name _____ Date _____

Homograph Answers

Instructions – Write the correct homograph next to its meaning in the following. Choose each homograph from those listed below.

quarter
letters
date

patient
plant
keys

palm
glasses
check

rare
line
head

1. A person under a doctor's care: _____
2. Implements you need to open a lock: _____
3. Written money that takes the place of cash: _____
4. The day of the month: _____
5. Something that is unusual: _____
6. A building containing equipment and machinery used for any industrial operation or work: _____
7. To have a social meeting with someone at a particular time or place: _____
8. The inner surface of the hand: _____
9. A leader, chief, or director: _____
10. A thin, continuous mark made by a pen or pencil: _____
11. Written symbols of speech sounds: _____
12. Containers that hold liquid such as water or milk: _____

Homographs are words which are spelled alike but have different meanings.

Name _____ Date _____

Homograph Sentences

Instructions – Choose any six homographs from the homograph list below. Then write two sentences for each homograph. Remember to use a different meaning in each sentence. Underline the homograph in each sentence.

quarter
letters
date

patient
plant
keys

palm
glasses
check

rare
line
head

1. _____
2. _____
3. _____
4. _____
5. _____
6. _____
7. _____
8. _____
9. _____
10. _____
11. _____
12. _____

Homographs are words which are spelled alike but have different meanings.

Name _____ Date _____

Homograph Sentence Scramble

Instructions – Unscramble these sentences. Write the correct sentences in the blanks under the scrambled sentences. Circle the homograph. Use the word list below for help.

quarter
letters
date

patient
plant
keys

palm
glasses
check

rare
line
head

1. A quarter today found and I put in it my piggy bank.

2. The back I sent the hamburger because it too was rare to cook.

3. Likes my dad my spelling to check after my homework I do.

4. Had I to wash the glasses because twice had they spots still.

5. Up order alphabetical had to we line in.

Homographs are words which are spelled alike but have different meanings.

Name _____ Date _____

Make Your Own Homograph

Instructions – In the boxes below, draw a picture of your favorite homographs. Write the name of each homograph under each picture.

--	--

--	--

© 1997 Super Duper® Publications 1-800-277-8737

Homographs are words which are spelled alike but have different meanings.

Name _____ Date _____

Homograph Crossword Puzzle

Instructions – Have fun filling in the crossword puzzle. Each of the answers is a homograph. You may choose your answers from the word list below.

quarter
letters
date

patient
plant
keys

palm
glasses
check

rare
line
head

Across

1. Containers for drinks
4. One fourth
5. Implements to open a lock
7. The alphabet is this
9. You are this when you wait without complaining
10. A tropical tree

Down

2. A sweet fruit
3. A bill at a restaurant
6. The opposite of well-done meat
7. A straight mark you make on paper with a pencil
8. It has hair on it
9. To put flower seeds in the ground

Homographs are words which are spelled alike but have different meanings.

Name _____ Date _____

Homographs

Homographs are words which are spelled alike but have two different meanings.

Instructions – The homographs listed below have two and sometimes three meanings. Yet, it is possible that some of the homographs can have even more meanings than those given in this lesson.

1. spring
2. straw
3. fork
4. race
5. spot
6. light

7. note
8. shade
9. watch
10. change
11. sink
12. stick

Correct the Homograph

Instructions – Fill in each blank in the sentences below with the correct homograph. Choose from the homograph list below. Remember to use each word in two and sometimes three sentences.

spring
straw
fork

race
spot
light

note
shade
watch

change
sink
stick

1. The farmer let us feed the _____ to the horses.
2. Some people in the primitive areas in Africa have never seen people of the white _____.
3. My good mood was ruined when I got a _____ of gravy on my new shirt.
4. When I go to the beach, I always sit under the _____ of an umbrella.
5. The tape was so old I couldn't get it to _____ on the paper.
6. We each took turns getting a cup of water from the _____.
7. I didn't realize I was late because my _____ had stopped.
8. Last night I was so tired I went to sleep while it was still _____ outside.
9. I wanted to _____ my good clothes into old clothes before I helped my father give my dog a bath.
10. The _____ on my bedroom window was broken and I couldn't pull it down.
11. My mother reminds me that the _____ always goes to the left of the plate when I set the table for dinner.
12. I lost the _____ from my ballpoint pen and I had to throw the pen away.

Homographs are words which are spelled alike but have different meanings.

Name _____ Date _____

Correct the Homograph

Continued

13. The hermit drank nothing but pure _____ water.
14. The movie began to get very exciting as soon as the boat began to _____.
15. Lemonade always tastes better to me when I drink it with a _____.
16. When the road separated, the bus driver took the right _____.
17. My favorite season of the year is _____ when the buds start to come out.
18. My lucky friend can always _____ a four-leaf clover when she looks for one in the grass.
19. My father said he saw a nice _____ to pitch a tent for the night.
20. I never _____ with my friend Carl anymore because he always wins.
21. The package was big, but it was very _____ to carry.
22. I had just enough _____ to pay for the bus fare home.
23. The teacher said she would write a _____ to herself so she wouldn't forget.
24. When the chorus sang the new song, I had trouble reaching the high _____ at the end.
25. Every New Year's Eve we _____ the ball fall in Times Square on T.V. when it is 12:00 A.M.
26. My grandmother always carries a _____ with her when she walks to scare away stray dogs.

Homographs are words which are spelled alike but have different meanings.

Name _____ Date _____

Name The Homographs

Instructions – Look at each set of pictures below. Choose the correct homographs for each set from the word list, and write it in the spaces provided.

spring
race

sink
change

watch
note

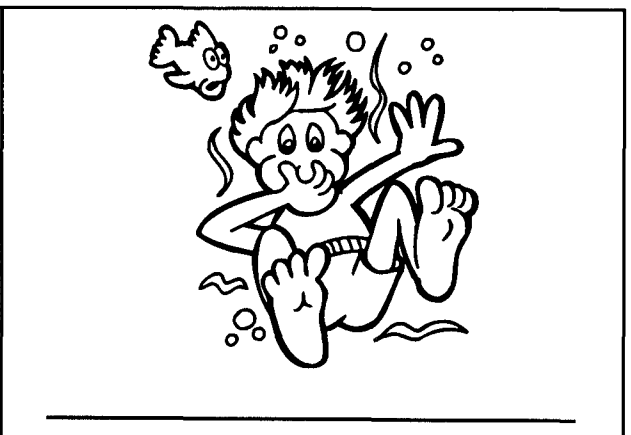
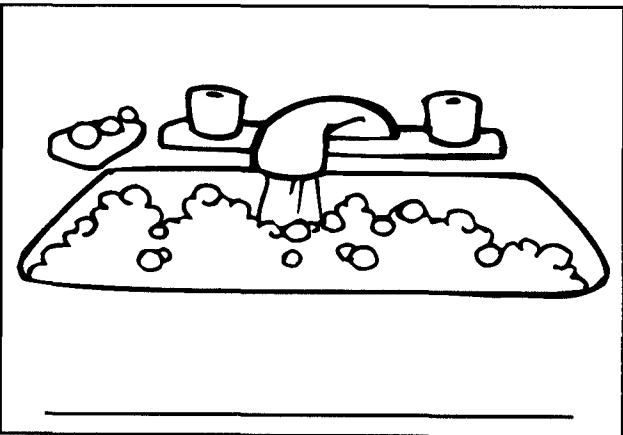
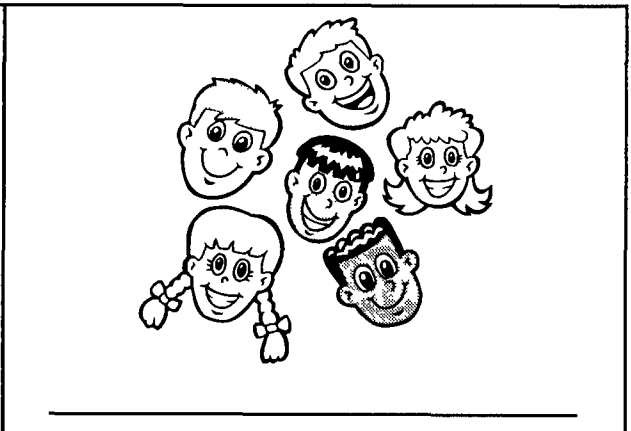
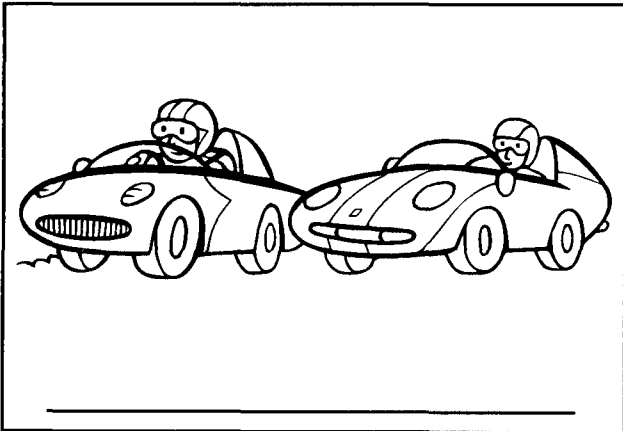
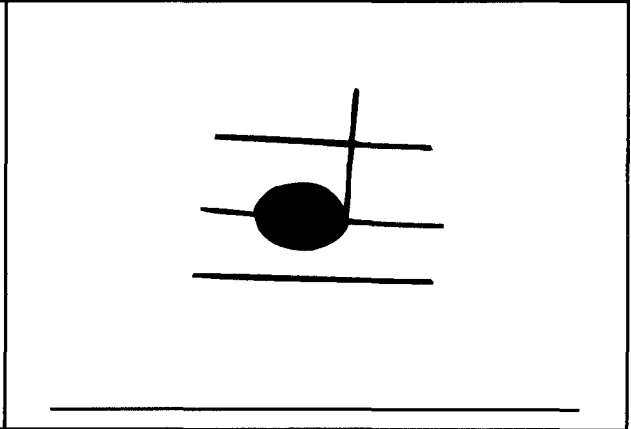

Homographs are words which are spelled alike but have different meanings.

Name _____ Date _____

Name The Homographs

Instructions – Look at each set of pictures below. Choose the correct homographs for each set from the word list, and write it in the spaces provided.

spring
race

sink
change

watch
note

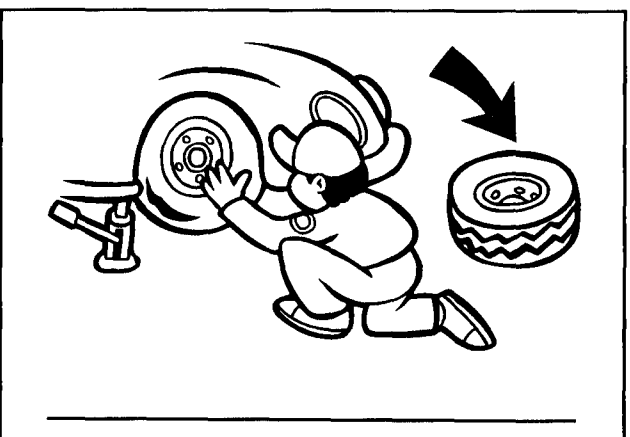
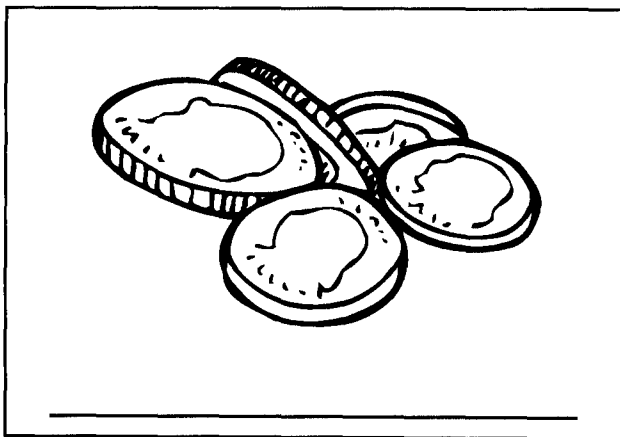
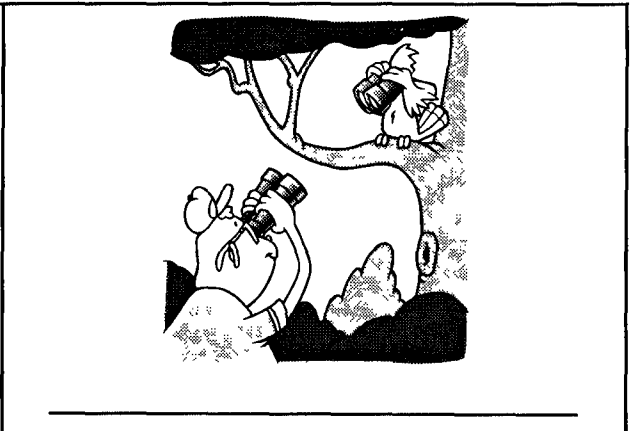
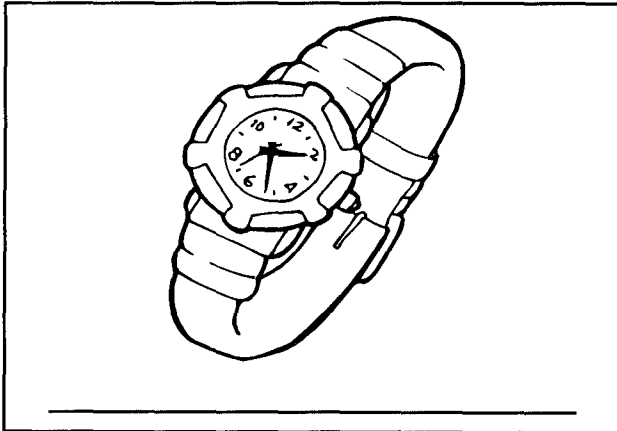
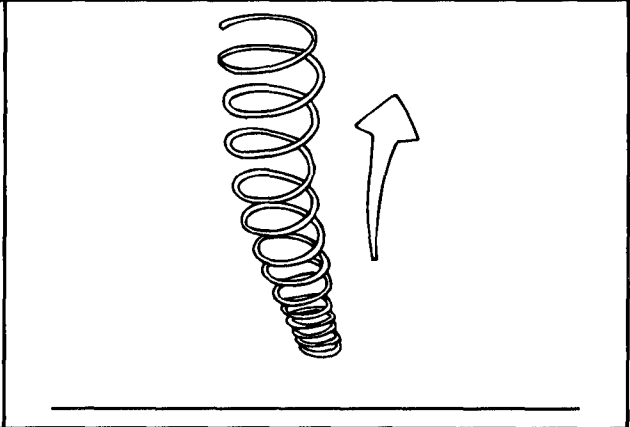
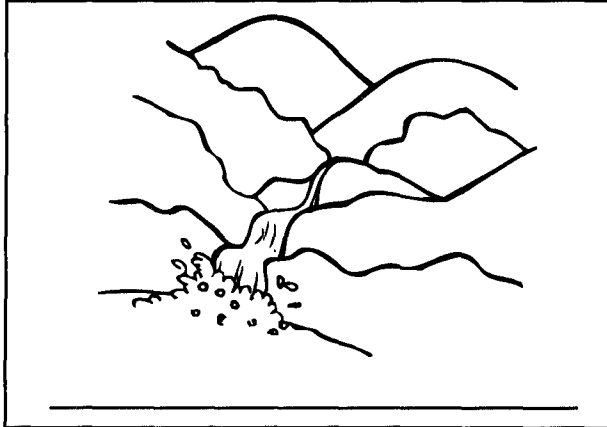

Homographs are words which are spelled alike but have different meanings.

Name _____ Date _____

Homograph Answers

Instructions – Write the correct homograph next to its meaning in the following. Choose each homograph from those listed below.

spring
straw
fork

race
spot
light

note
shade
watch

change
sink
stick

1. A natural fountain or flow of water: _____
2. Opposite of heavy: _____
3. A group of people different from others because of color of skin:

4. Stalks used as food for animals: _____
5. To detect or find something: _____
6. Information on a piece of paper: _____
7. An implement with prongs used for eating: _____
8. A place where the sun is not shining: _____
9. To cause to be different in some way: _____
10. A place where you wash dishes or your hands: _____
11. To look at something: _____
12. A long, thin piece of wood from a tree: _____

Homographs are words which are spelled alike but have different meanings.

Name _____ Date _____

Homograph Sentences

Instructions – Choose any six homographs from the homograph list below. Then, write two sentences for each homograph. Remember to use a different meaning in each sentence. Underline the homograph in each sentence.

spring

race

note

change

straw

spot

shade

sink

fork

light

watch

stick

1. _____

2. _____

3. _____

4. _____

5. _____

6. _____

7. _____

8. _____

9. _____

10. _____

11. _____

12. _____

Homographs are words which are spelled alike but have different meanings.

Name _____ Date _____

Homograph Sentence Scramble

Instructions – Unscramble these sentences. Write the correct sentences in the blanks under the scrambled sentences. Circle the homograph. Use the word list below for help.

spring

race

note

change

straw

spot

shade

sink

fork

light

watch

stick

1. Sticking out was of the old spring a couch.

2. For a picnic found we a spot nice.

3. The light dark in the hallway on I turned.

4. Some a dollar and I had change left.

5. Go out I can't tonight because my sister watch I have to baby.

Homographs are words which are spelled alike but have different meanings.

Name _____ Date _____

Make Your Own Homograph

Instructions – In the boxes below, draw a picture of your favorite homographs. Write the name of each homograph under each picture.

--	--

--	--

Homographs are words which are spelled alike but have different meanings.

Name _____ Date _____

Homograph Crossword Puzzle

Instructions – Have fun filling in the crossword puzzle. Each of the answers is a homograph. You may choose your answers from the word list below.

spring
straw
fork

race
spot
light

note
shade
watch

change
sink
stick

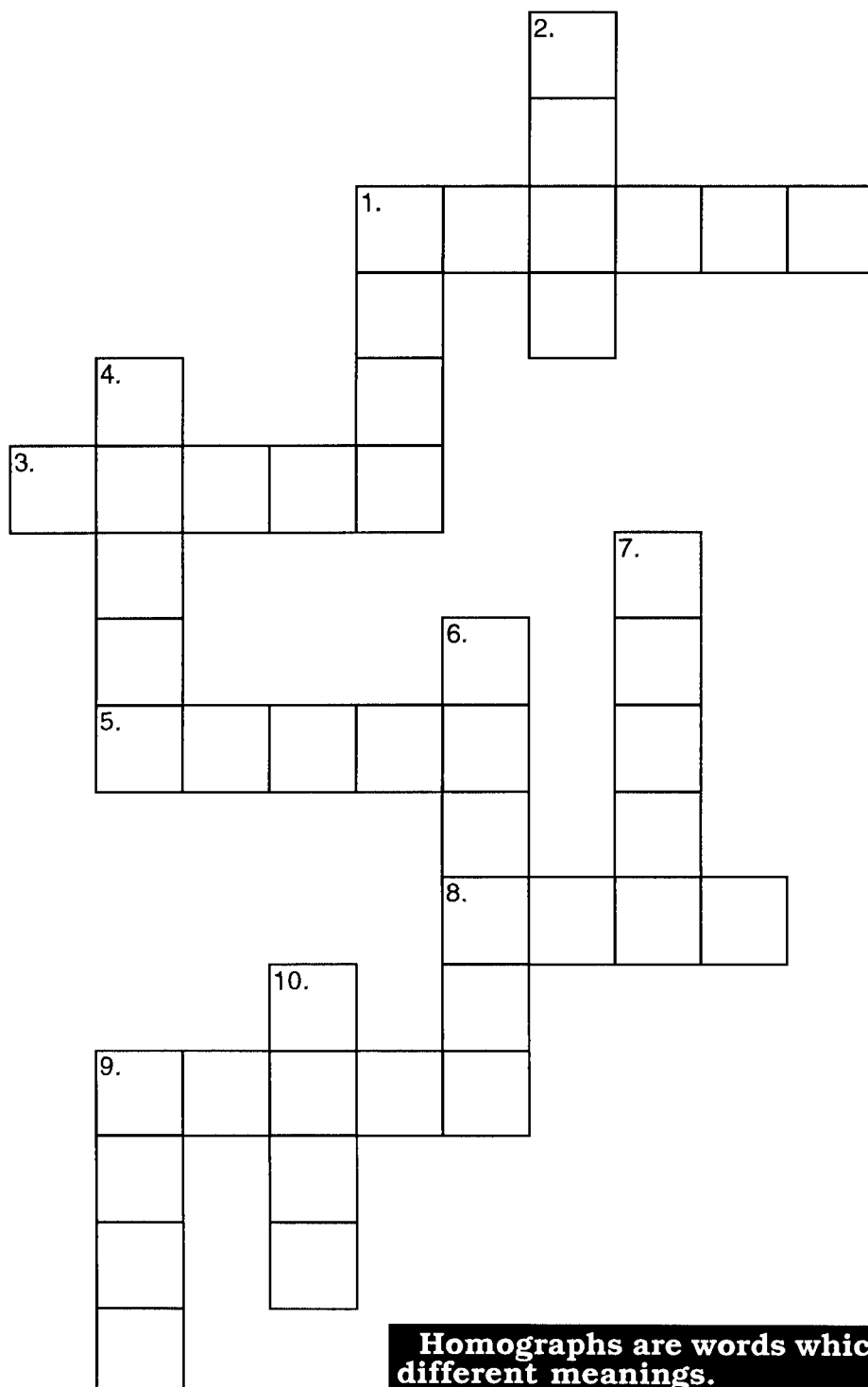

Across

1. A season
3. A piece of wood
5. A piece of jewelry you wear
8. Something you can sing
9. This covers a window to keep the light out

Down

1. To go under the water and not come up again
2. Where a road separates into two parts
4. It helps you drink your juice or milk
6. To alter or rearrange
7. The sun gives us this
9. To see something
10. A contest to see who can run the fastest

Homographs are words which are spelled alike but have different meanings.

Name _____ Date _____

Answer Key

Vocabulary Building • Answer Key

ANTONYMS

Page 2 - Choose the Correct Antonyms

1. punish, reward
2. depart, arrive
3. doctor, patient
4. polite, rude
5. comfort, disturb
6. freeze, thaw
7. guilty, innocent
8. comedy, tragedy
9. entrance, exit
10. vacant, occupied
11. valuable, worthless
12. tunnel, bridge

Page 3 - Which Antonym Is It?

1. punish him/her
2. guilty
3. a patient
4. depart
5. comfort him/her
6. thaw
7. entrance
8. worthless
9. polite
10. a tragedy
11. a tunnel
12. occupied

Page 4 - Name The Antonyms

1. patient
2. depart
3. worthless

Page 5 - Name The Antonyms

1. tunnel
2. freeze
3. disturb

Page 6 - Find New Antonyms

1. arrive
2. comfort
3. polite
4. vacant
5. guilty

Page 8 - Antonym Crossword Puzzle

- | <u>Across</u> | <u>Down</u> |
|---------------|-------------|
| 2. occupied | 1. polite |
| 4. disturb | 3. depart |
| 6. innocent | 5. doctor |
| 8. worthless | 7. comedy |
| 10. freeze | 9. bridge |
| 11. reward | |
| 12. exit | |

Page 10 - Choose the Correct Antonyms

1. break, repair
2. best, worst
3. wise, foolish
4. destroy, create
5. most, least

Page 10 - Choose the Correct Antonyms Cont.

6. decrease, increase
7. always, never
8. fancy, plain
9. smile, frown
10. employee, boss
11. sour, sweet
12. nephew, niece

Page 11 - Which Antonym Is It?

1. an employee
2. decrease the amount of money
3. the most
4. fancy
5. repair it
6. foolish
7. sweet
8. a frown
9. create it
10. a nephew
11. never
12. your best

Page 12 - Name The Antonyms

1. repair
2. decrease
3. sour

Page 13 - Name The Antonyms

1. destroy
2. smile
3. plain

Page 14 - Find New Antonyms

1. break
2. always
3. boss
4. fancy
5. increase

Page 16 - Antonym Crossword Puzzle

- | <u>Across</u> | <u>Down</u> |
|---------------|-------------|
| 1. create | 2. always |
| 3. smile | 4. plain |
| 5. employee | 6. decrease |
| 8. wise | 7. repair |
| 10. niece | 9. sweet |
| 12. least | 11. best |

Page 18 - Choose the Correct Antonyms

1. easy, difficult
2. ordinary, unusual
3. trust, doubt
4. fat, skinny
5. country, city
6. raw, cooked
7. stale, fresh
8. serious, silly
9. many, few
10. awkward, graceful
11. similar, different
12. all, none

Page 19 - Which Antonym Is It?

1. many
2. unusual
3. difficult
4. awkward
5. silly
6. skinny
7. doubt
8. raw
9. all
10. city
11. similar
12. stale

Page 20 - Name The Antonyms

1. skinny
2. cooked
3. different

Page 21 - Name The Antonyms

1. many
2. difficult
3. unusual

Page 22 - Find New Antonyms

1. few
2. easy
3. fat
4. unusual
5. graceful

Page 24 - Antonym Crossword Puzzle

- | <u>Across</u> | <u>Down</u> |
|---------------|-------------|
| 1. graceful | 2. city |
| 3. trust | 5. silly |
| 4. skinny | 6. unusual |
| 7. easy | 9. raw |
| 8. many | 11. all |
| 10. similar | |
| 12. stale | |

Page 26 - Choose the Correct Antonyms

1. give, receive
2. present, absent
3. majority, minority
4. fact, fiction
5. teacher, student
6. bright, dim
7. unknown, famous
8. villain, hero
9. private, public
10. praise, insult
11. interested, bored
12. enemy, friend

Page 27 - Which Antonym Is It?

1. a friend
2. an insult
3. a student
4. bored
5. a villain
6. dim

Vocabulary Building • Answer Key

Page 27 - Which Antonym Is It? Cont.

7. receive it
8. private
9. famous
10. the minority
11. present
12. facts

Page 28 - Name The Antonyms

1. present
2. student
3. villain

Page 29 - Name The Antonyms

1. receive
2. bright
3. private

Page 30 - Find New Antonyms

1. teacher
2. interested
3. give
4. friend
5. insult

Page 32 - Antonym Crossword Puzzle

- | <u>Across</u> | <u>Down</u> |
|---------------|---------------|
| 2. give | 1. minority |
| 3. hero | 4. interested |
| 4. insult | 5. absent |
| 6. student | 7. public |
| 8. famous | 8. fact |
| 9. enemy | 10. dim |

Page 34 - Choose the Correct Antonyms

1. cheerful, sad
2. notice, ignore
3. bold, timid
4. familiar, strange
5. straight, crooked
6. exclude, include
7. allow, refuse
8. kind, cruel
9. past, future
10. part, whole
11. wife, husband
12. dangerous, safe

Page 35 - Which Antonym Is It?

1. exclude him/her
2. crooked
3. cheerful
4. ignore it
5. allow it
6. in the future
7. a part
8. familiar
9. a wife
10. dangerous
11. timid
12. cruel

Page 36 - Name The Antonyms

1. wife
2. crooked
3. cheerful

Page 37 - Name The Antonyms

1. dangerous
2. part
3. ignore

Page 38 - Find New Antonyms

1. include
2. sad
3. kind
4. bold
5. notice

Page 40 - Antonym Crossword Puzzle

- | <u>Across</u> | <u>Down</u> |
|---------------|--------------|
| 1. exclude | 2. cheerful |
| 3. safe | 4. refuse |
| 5. future | 6. bold |
| 7. crooked | 8. husband |
| 9. whole | 10. familiar |
| 11. notice | 12. cruel |

SYNONYMS

Page 42 - Choose the Correct Synonyms

1. choose or pick
2. watch
3. companion or friend
4. winner or champion
5. above or over
6. under or beneath
7. simple or easy
8. permit or allow
9. request
10. drag or pull
11. chubby or plump
12. close

Page 43 - Which Synonym Is It?

1. a companion
2. above us
3. chubby
4. choose
5. beneath the bed
6. the owner wouldn't allow it
7. simple
8. the champion
9. request it
10. close to you
11. watch them
12. pull it

Page 44 - Name The Synonyms

1. pick, choose
2. near, close
3. friend, companion
4. over, above

Page 44 - Name The Synonyms Cont.

5. pull, drag
6. ask, request

Page 45 - Name The Synonyms

1. chubby, plump
2. under, beneath
3. watch, look
4. allow, permit
5. champion, winner
6. simple, easy

Page 46 - Find the Synonym

1. beneath
2. choose or pick
3. friend
4. watch
5. chubby or plump

Page 46 - Synonym Scramble

1. beneath
2. allow
3. simple
4. winner
5. request

Page 48 - Synonym Crossword Puzzle

- | <u>Across</u> | <u>Down</u> |
|---------------|-------------|
| 1. companion | 2. allow |
| 3. simple | 4. near |
| 5. request | 6. under |
| 8. winner | 7. choose |
| 10. chubby | 8. watch |
| | 9. pull |
| | 11. above |

Page 50 - Choose the Correct Synonyms

1. build or construct
2. name or title
3. vanish or disappear
4. far or distant
5. discover or find
6. stay or remain
7. belief or opinion
8. middle or center
9. brave or bold
10. prank or joke
11. rich or wealthy
12. silly or foolish

Page 51 - Which Synonym Is It?

1. foolish
2. build houses
3. an opinion
4. a name
5. remain
6. bold
7. rich
8. a prank
9. in the middle
10. distant
11. discover new countries or places
12. disappear

Vocabulary Building • Answer Key

Page 52 - Name The Synonyms

1. prank, joke
2. build, construct
3. brave, bold
4. far, distant
5. belief, opinion
6. find, discover

Page 53 - Name The Synonyms

1. middle, center
2. rich, wealthy
3. name, title
4. remain, stay
5. silly, foolish
6. vanish, disappear

Page 54 - Find the Synonym

1. joke, prank
2. name
3. build, construct
4. silly, foolish
5. brave, bold

Page 54 - Synonym Scramble

1. wealthy
2. remain
3. vanish
4. center
5. discover

Page 56 - Synonym Crossword Puzzle

<u>Across</u>		<u>Down</u>	
1. disappear	2. middle	4. find	3. construct
5. brave	6. opinion	7. distant	8. prank
9. rich	9. remain	10. silly	

Page 58 - Choose the Correct Synonyms

1. cruel or mean
2. last or final
3. join or connect
4. give or donate
5. misplaced or lost
6. first or initial
7. wet or damp
8. smart or intelligent
9. help or assist
10. error or mistake
11. short or brief
12. trail or path

Page 59 - Which Synonym Is It?

1. first
2. cruel
3. help
4. path
5. final
6. brief
7. damp
8. intelligent

Page 59 - Which Synonym Is It? Cont.

9. make an error
10. misplaced
11. connect them
12. donate them to charity

Page 60 - Name The Synonyms

1. wet, damp
2. first, initial
3. last, final
4. give, donate
5. lost, misplaced
6. short, brief

Page 61 - Name The Synonyms

1. smart, intelligent
2. help, assist
3. trail, path
4. error, mistake
5. join, connect
6. mean, cruel

Page 62 - Find the Synonym

1. smart, intelligent
2. damp, wet
3. last, final
4. help, assist
5. mean, cruel

Page 62 - Synonym Scramble

1. assist
2. connect
3. trail
4. misplaced
5. cruel

Page 64 - Synonym Crossword Puzzle

<u>Across</u>		<u>Down</u>	
1. misplaced	2. intelligent	3. mistake	4. cruel
5. final	7. initial	6. wet	9. trail
8. connect	11. brief	10. assist	12. donate

Page 66 - Choose the Correct Synonyms

1. vacant
2. response
3. stingy or miserly
4. fantasy or daydream
5. buy or purchase
6. messy
7. wrong
8. piece
9. funny or amusing
10. teacher or instructor
11. wages
12. guest

Page 67 - Which Synonym Is It?

1. vacant
2. stingy
3. false

Page 67 - Which Synonym Is It? Cont.

4. a piece
5. funny
6. a response
7. an instructor
8. a daydream
9. purchase
10. a salary
11. a visitor
12. untidy

Page 68 - Name The Synonyms

1. portion, piece
2. fantasy, daydream
3. funny, amusing
4. empty, vacant
5. messy, untidy
6. buy, purchase

Page 69 - Name The Synonyms

1. answer, response
2. teacher, instructor
3. wages, salary
4. false, wrong
5. stingy, miserly
6. guest, visitor

Page 70 - Find the Synonym

1. piece, portion
2. empty, vacant
3. response
4. funny, amusing
5. stingy, miserly

Page 70 - Synonym Scramble

1. portion
2. daydream
3. guest
4. false
5. purchase

Page 72 - Synonym Crossword Puzzle

<u>Across</u>		<u>Down</u>	
1. guest	2. untidy	3. instructor	4. stingy
7. funny	5. purchase	8. empty	6. wrong
11. wages	7. fantasy		9. response
	10. piece		

Page 74 - Choose the Correct Synonyms

1. real or genuine
2. often or frequently
3. careful or cautious
4. new or unused
5. copy or imitate
6. agree or consent
7. seldom or rarely
8. strange or odd
9. quiet or silent
10. maybe or perhaps
11. busy or active
12. frightened or scared

Vocabulary Building • Answer Key

Page 75 - Which Synonym Is It?

- genuine
- seldom
- odd
- often
- imitate
- busy
- frightened
- perhaps
- cautious
- agree
- quiet
- unused

Page 76 - Name The Synonyms

- agree, consent
- busy, active
- frightened, scared
- real, genuine
- careful, cautious
- new, unused

Page 77 - Name The Synonyms

- imitation, copy
- silent, quiet
- strange, odd
- often, frequently
- perhaps, maybe
- rarely, seldom

Page 78 - Find the Synonym

- real, genuine
- new, unused
- imitates, copies
- scared, frightened
- strange, odd

Page 78 - Synonym Scramble

- maybe
- silent
- active
- strange
- genuine

Page 80 - Synonym Crossword Puzzle

- | <u>Across</u> | <u>Down</u> |
|---------------|---------------|
| 1. cautious | 2. strange |
| 3. agree | 4. imitate |
| 5. frightened | 5. frequently |
| 6. rarely | 7. perhaps |
| 8. unused | 9. genuine |
| 10. busy | |
| 11. quiet | |

HOMOPHONES

Pages 82-83 - Choose the Correct Homophone

- aunt
- ant
- beat
- beet
- bee
- be

Pages 82-83 - Choose the Correct Homophone Cont.

- bury
- berry
- scent
- sent
- cent
- cord
- chord
- ale
- ail
- bear
- bare
- l
- eye
- flour
- flower
- earn
- urn
- ewe
- you

Page 84 - Name The Homophone

- beet, beat
- bear, bare
- eye, l

Page 85 - Name The Homophone

- flour, flower
- berry, bury
- urn, earn

Page 86 - Which Homophone Is It?

- bare
- beat it
- bury it
- a scent
- a cord
- a flower
- earn money
- you
- aunt
- flour
- a bee
- to ail

Page 87 - Correction Time

- l
- ewe
- beet
- bury
- be
- sent
- chord
- ale
- flower
- urn
- cent
- aunt
- flower
- bear
- berry

Page 87 - Correction Time Cont.

- scent
- cord
- earn
- ant
- bee

Page 88 - Hidden Homophone

- ruby
- cents
- run
- tan
- wee

Page 90 - Homophone Crossword Puzzle

- | <u>Across</u> | <u>Down</u> |
|---------------|-------------|
| 1. bury | 1. beat |
| 2. bare | 4. ant |
| 3. ail | 5. berry |
| 4. aunt | 6. ale |
| 5. beet | 7. ewe |
| 8. earn | 9. sent |
| 9. scent | 12. cord |
| 10. eye | |
| 11. flower | |

Pages 92-93 - Choose the Correct Homophone

- raise
- rays
- vein
- vane
- vain
- rode
- road
- forth
- fourth
- hear
- here
- tide
- tied
- rein
- rain
- reign
- too
- to
- two
- toad
- towed
- steel
- steal
- seem
- seam
- waist
- waste

Page 94 - Name The Homophone

- waist, waste
- towed, toad
- rays, raise

Page 95 - Name The Homophone

- road, rode
- rain, rein
- two, to

Vocabulary Building • Answer Key

Page 96 - Which Homophone Is It?

1. raise it
2. vein
3. road
4. the fourth
5. hear
6. tied them
7. reign
8. too
9. toad
10. steel
11. a seam
12. waste

Page 97 - Correction Time

1. vane
2. fourth
3. road
4. tied
5. rain
6. hear
7. two
8. toad
9. steal
10. seem
11. too
12. waste
13. rode
14. vain
15. raise
16. here
17. steal
18. waist
19. vain
20. to

Page 98 - Hidden Homophone

1. hare
2. diet
3. least
4. same
5. waits

Page 100 - Homophone Crossword Puzzle

- | <u>Across</u> | <u>Down</u> |
|---------------|-------------|
| 1. rain | 1. road |
| 3. rays | 2. vain |
| 4. reign | 3. raise |
| 5. waste | 6. towed |
| 7. seam | 7. steel |
| 8. waist | 10. rode |
| 9. hear | 12. toad |
| 11. steal | 13. too |
| 12. two | |

Page 102-103 - Choose the Correct Homophone

1. ate
2. eight
3. bough
4. bow
5. blue
6. blew
7. by

Page 102-103 - Choose the Correct Homophone Cont.

8. buy
9. not
10. knot
11. capital
12. Capitol
13. cheap
14. cheep
15. flee
16. flea
17. fowl
18. foul
19. arc
20. ark
21. knight
22. night
23. bald
24. bawled

Page 104 - Name The Homophone

1. knight, night
2. arc, ark
3. bawled, bald

Page 105 - Name The Homophone

1. cheep, cheap
2. blue, blew
3. eight, ate

Page 106 - Which Homophone Is It?

1. blew on it
2. a bough
3. ate it
4. buy them
5. a knot
6. the Capitol
7. night
8. cheap
9. a flea
10. a fowl
11. an arc
12. bald

Page 107 - Correction Time

1. bald
2. night
3. bow
4. not
5. buy
6. flea
7. foul
8. blew
9. cheap
10. ate
11. ark
12. capital
13. blue
14. knot
15. by
16. eight
17. flee

Page 107 - Correction Time Cont.

18. knight
19. fowl
20. bough

Page 108 - Hidden Homophones

1. peach
2. wolf
3. car
4. leaf
5. tea

Page 110 - Homophone Crossword Puzzle

- | <u>Across</u> | <u>Down</u> |
|---------------|-------------|
| 2. fowl | 1. cheep |
| 3. capital | 2. foul |
| 6. knight | 4. ate |
| 8. blue | 5. ark |
| 9. cheap | 7. night |
| 11. eight | 8. bough |
| 12. not | 10. arc |

Pages 112-113 - Choose the Correct Homophone

1. where
2. wear
3. write
4. right
5. root
6. route
7. prays
8. praise
9. preys
10. plain
11. plane
12. patients
13. patience
14. grown
15. groan
16. soar
17. sore
18. know
19. no
20. knows
21. nose
22. witch
23. which
24. way
25. weigh

Page 114 - Name The Homophones

1. plane, plain
2. knows, nose
3. witch, which

Page 115 - Name The Homophones

1. right, write
2. route, root
3. sore, soar

Vocabulary Building • Answer Key

Page 116 - Which Homophone Is It?

- wear them
- right
- the route
- praise
- plain
- patience
- full grown
- sore
- no
- nose
- which one?
- weigh yourself

Page 117 - Correction Time

- where
- right
- root
- which
- know
- knows
- praise
- patience
- sore
- plain
- groan
- no
- which
- weigh
- wear
- root
- plane
- write
- preys
- grown

Page 118 - Hidden Homophones

- spray
- panel
- wrong
- rose
- on

Page 120 - Homophone Crossword Puzzle

- | <u>Across</u> | <u>Down</u> |
|---------------|-------------|
| 1. wear | 1. way |
| 2. prays | 2. patience |
| 3. praise | 4. route |
| 4. root | 5. soar |
| 6. write | 7. groan |
| 8. grown | 9. knows |
| 10. patients | 11. witch |
| 12. weigh | 13. plane |
| 13. plain | 14. sore |

Pages 122-123 - Choose the Correct Homophone

- whole
- hole
- dye
- die
- lead
- led
- won

Pages 122-123 - Choose the Correct Homophone Cont.

- one
- pair
- pear
- pale
- pail
- sea
- see
- paws
- pause
- hour
- our
- dense
- dents
- grate
- great
- grate
- there
- their

Page 124 - Name The Homophones

- one, won
- die, dye
- pair, pear

Page 125 - Name The Homophones

- pail, pale
- hole, whole
- see, sea

Page 126 - Which Homophone Is It?

- the whole
- die
- lead
- won
- a pair
- pale skin
- the sea
- paws
- hour
- dents
- grate
- there

Page 127 - Correction Time

- whole
- led
- won
- pair
- pail
- see
- paws
- hour
- dents
- great
- there
- sea
- hole
- die
- led
- pause

Page 127 - Correction Time Cont.

- pear
- pale
- great
- one

Page 128 - Hidden Homophones

- deal
- now
- leap
- needs
- swap

Page 130 - Homophone Crossword Puzzle

- | <u>Across</u> | <u>Down</u> |
|---------------|-------------|
| 1. their | 2. die |
| 4. pause | 3. whole |
| 6. led | 4. pale |
| 8. dents | 5. sea |
| 9. pair | 7. dye |
| 11. there | 9. paws |
| 12. hole | 10. great |
| 13. dense | 12. hour |
| | 14. see |

HOMOGRAPHS

Pages 132-133 - Correct the Homographs

- pool
- pitcher
- star
- batter
- pit
- top
- ruler
- school
- chest
- school
- star
- scale
- bat
- pool
- pitcher
- ruler
- scale
- top
- block
- pit
- chest
- block
- bat
- scale
- pool
- batter

Page 134 - Name The Homographs

- bat
- pool
- chest

Page 135 - Name The Homographs

- top
- batter
- pitcher

Vocabulary Building • Answer Key

Page 136 - Homograph Answers

1. ruler
2. block
3. school
4. chest
5. pitcher
6. top
7. pit
8. batter
9. scale
10. bat
11. pool
12. star

Page 138 - Homograph Sentence Scramble

1. I walked my dog around the block.
2. I wanted to be a star in my class play.
3. A star is only seen from Earth at night.
4. The snow covered the top of the mountain.
5. I planted the avocado pit in the soil in my garden.

Page 140 - Homograph Crossword Puzzle

- | Across | Down |
|-----------|------------|
| 1. block | 2. ruler |
| 4. batter | 3. chest |
| 7. pool | 4. bat |
| 8. scale | 5. top |
| 9. pit | 6. school |
| 10. star | 9. pitcher |

Page 142-143 - Correct the Homographs

1. club
2. cast
3. pipe
4. sole
5. pen
6. tip
7. diamond
8. nail
9. foot
10. tip
11. pupil
12. part
13. back
14. sole
15. pipe
16. pen
17. club
18. club
19. tip
20. cast
21. back
22. nail
23. part

Page 144 - Name The Homographs

1. cast
2. back
3. diamond

Page 145 - Name The Homographs

1. pen
2. pipe
3. foot

Page 146 - Homograph Answers

1. pipe
2. pen
3. sole
4. back
5. diamond
6. part
7. cast
8. foot
9. nail
10. tip
11. club
12. pupil

Page 148 - Homograph Sentence Scramble

1. The cast had a party after the play.
2. I stood in the back of the auditorium because there were no seats.
3. I stepped on my baby sister's foot by mistake, and she screamed.
4. Dad had a sore on the sole of his foot.
5. I sat in back of home base on the baseball diamond.

Page 150 - Homograph Crossword Puzzle

- | Across | Down |
|------------|---------|
| 1. diamond | 2. nail |
| 3. pupil | 3. pen |
| 6. sole | 4. pipe |
| 8. back | 5. cast |
| 10. part | 7. club |
| 11. foot | 9. tip |

Page 152-153 - Correct the Homographs

1. seal
2. story
3. pound
4. ring
5. switch
6. teeth
7. pound
8. yard
9. file
10. page
11. bill
12. tape
13. ball
14. pound
15. page

Page 152-153 - Correct the Homographs Cont.

16. page
17. seal
18. teeth
19. story
20. yard
21. ring
22. file
23. bill
24. ball
25. switch
26. tape

Page 154 - Name The Homographs

1. teeth
2. page
3. switch

Page 155 - Name The Homographs

1. tape
2. seal
3. yard

Page 156 - Homograph Answers

1. yard
2. page
3. seal
4. teeth
5. story
6. pound
7. ball
8. ring
9. switch
10. tape
11. file
12. bill

Page 158 - Homograph Sentence Scramble

1. We watched the seal at the circus balance a ball on its nose.
2. My sister wanted to switch her aisle seat for a window seat.
3. The bill came to one hundred dollars.
4. You must push the bell hard for it to ring.
5. I wanted to tape all the pictures into my scrapbook.

Page 160 - Homograph Crossword Puzzle

- | Across | Down |
|-----------|----------|
| 1. story | 2. teeth |
| 4. page | 3. yard |
| 5. ring | 6. seal |
| 6. switch | 7. tape |
| 8. file | 10. ball |
| 9. pound | |
| 10. bill | |

Vocabulary Building • Answer Key

Page 162-163 - Correct the Homographs

1. patient
2. glasses
3. head
4. line
5. rare
6. keys
7. letters
8. check
9. palm
10. date
11. quarter
12. rare
13. keys
14. palm
15. head
16. patient
17. plant
18. date
19. quarter
20. line
21. plant
22. glasses
23. date
24. letters
25. check
26. check

Page 164 - Name The Homographs

1. letters
2. check
3. keys

Page 165 - Name The Homographs

1. glasses
2. palm
3. plant

Page 166 - Homograph Answers

1. patient
2. keys
3. check
4. date
5. rare
6. plant
7. date
8. palm
9. head
10. line
11. letters
12. glasses

Page 168 - Homograph Sentence Scramble

1. I found a quarter today and put it in my piggy bank.
2. I sent the hamburger back to the cook because it was too rare.
3. My dad likes to check my spelling after I do my homework.

Page 168 - Homograph Sentence Scramble Cont.

4. I had to wash the glasses twice because they still had spots.
5. We had to line up in alphabetical order.

Page 170 - Homograph Crossword Puzzle

- | <u>Across</u> | <u>Down</u> |
|---------------|-------------|
| 1. glasses | 2. date |
| 4. quarter | 3. check |
| 5. keys | 6. rare |
| 7. letters | 7. line |
| 9. patient | 8. head |
| 10. palm | 9. plant |

Page 172-173 - Correct the Homographs

1. straw
2. race
3. spot
4. shade
5. stick
6. sink
7. watch
8. light
9. change
10. shade
11. fork
12. spring
13. spring
14. sink
15. straw
16. fork
17. spring
18. spot
19. spot
20. race
21. light
22. change
23. note
24. note
25. watch
26. stick

Page 174 - Name The Homographs

1. note
2. race
3. sink

Page 175 - Name The Homographs

1. spring
2. watch
3. change

Page 176 - Homograph Answers

1. spring
2. light
3. race
4. straw
5. spot
6. note

Page 176 - Homograph Answers Cont.

7. fork
8. shade
9. change
10. sink
11. watch
12. stick

Page 178 - Homograph Sentence Scramble

1. A spring was sticking out of the old couch.
2. We found a nice spot for a picnic.
3. I turned the light on in the dark hallway.
4. I had a dollar and some change left.
5. I can't go out tonight because I have to watch my baby sister.

Page 180 - Homograph Crossword Puzzle

- | <u>Across</u> | <u>Down</u> |
|---------------|-------------|
| 1. spring | 1. sink |
| 3. stick | 2. fork |
| 5. watch | 4. straw |
| 8. note | 6. change |
| 9. shade | 7. light |
| | 9. spot |
| | 10. race |